

Listening and Voice

Phenomenologies of Sound
second edition



Don Ihde

Listening and Voice

This page intentionally left blank.

Listening and Voice

Phenomenologies of Sound

SECOND EDITION

Don Ihde

State University of New York Press

Published by
State University of New York Press, Albany

© 2007 State University of New York

All rights reserved

Printed in the United States of America

No part of this book may be used or reproduced in any manner whatsoever without written permission. No part of this book may be stored in a retrieval system or transmitted in any form or by any means including electronic, electrostatic, magnetic tape, mechanical, photocopying, recording, or otherwise without the prior permission in writing of the publisher.

For information, contact State University of New York Press, Albany, NY
www.sunypress.edu

Production by Michael Haggett and Marilyn Semerad
Marketing by Michael Campochario

Library of Congress Cataloging-in-Publication Data

Ihde, Don, 1934–

Listening and voice : phenomenologies of sound / Don Ihde. — 2nd ed.
p. cm.

Includes bibliographical references and index.

ISBN 978-0-7914-7255-2 (hardcover : alk. paper) — ISBN 978-0-7914-7256-9
(pbk. : alk. paper) 1. Phenomenology. 2. Listening (Philosophy) 3. Voice
(Philosophy) I. Title.

B829.5.I34 2007

128'.3—dc22

2006100232

10 9 8 7 6 5 4 3 2 1

*For
Judith Lochhead,
my longtime colleague and collaborator
and the
Stony Brook Music Department*

This page intentionally left blank.

Contents

List of Illustrations	ix
Preface to the SUNY Press Edition	xi
Introduction (to the Original)	xix

PART I INTRODUCTION

Chapter 1	In Praise of Sound	3
Chapter 2	Under the Signs of Husserl and Heidegger	17
Chapter 3	First Phenomenology	25

PART II DESCRIPTION

Chapter 4	The Auditory Dimension	49
Chapter 5	The Shapes of Sound	57
Chapter 6	The Auditory Field	73
Chapter 7	Timeful Sound	85
Chapter 8	Auditory Horizons	103

PART III THE IMAGINATIVE MODE

Chapter 9	The Polyphony of Experience	115
Chapter 10	Auditory Imagination	131
Chapter 11	Inner Speech	137

PART IV VOICE

Chapter 12	The Center of Language	147
Chapter 13	Music and Word	155
Chapter 14	Silence and Word	161
Chapter 15	Dramaturgical Voice	167
Chapter 16	The Face, Voice, and Silence	177

PART V PHENOMENOLOGIES

Chapter 17	A Phenomenology of Voice	185
Chapter 18	Auditory Imagination	203
Chapter 19	Listening	217

PART VI ACOUSTIC TECHNOLOGIES

Chapter 20	Bach to Rock: Amplification	227
Chapter 21	Jazz Embodied: Instrumentation	235
Chapter 22	Embodying Hearing Devices: Digitalization	243
Chapter 23	Embodiment, Technologies, and Musics	251
Notes		265
Index		273

Illustrations

3.1	Core-Horizon Structure	39
4.1	Horizon of Invisibility	52
4.2	Horizon of Silence	52
4.3	Auditory-Visual Overlap	53
7.1	Husserl's Time Diagram	92
7.2	Temporal Focus	93
7.3	Temporal Span	95
7.4	Focal Direction	99
8.1	Focus Field Horizon Structure	106
9.1	Perception-Imagination Overlap	127
17.1	Multistable Image	188

This page intentionally left blank.

Preface to the
SUNY Press Edition of
*Listening and Voice:
Phenomenologies of Sound*

The first edition of *Listening and Voice* (1976), the manuscript for which was completed (1972–73) roughly a decade after my dissertation (1964), was my first systematic attempt to *do* an original phenomenology. I was already convinced that what I later termed, “generic continentalism,” that is, the brand of scholarship that focuses on some major European philosopher and his or her texts, did not promise the same excitement of a more ‘experimental,’ actual phenomenological investigation. Scholarship of that generic sort does have value—my own first book, *Hermeneutic Phenomenology: The Philosophy of Paul Ricoeur* (1971) was an example of exactly that genre. *Doing* phenomenology, however, implies a *research program*. That was what *Listening and Voice* undertook; it produced the results of a multiyear research program focused on auditory experience. The origin of this program was unintentionally accidental in one sense: disappointed that my own proposal for a paper at an early SPEG conference was rejected, I was asked instead to be part of a panel on “perceiving persons,” with Frank Tilman and David Carr. Tilman, as lead presenter, circulated a paper that was classically “Cartesian” in that his leading example of person perception was to be found in a question about whether or not we could be (visually) fooled by a cleverly contrived robot? Convinced on my part that much person perception occurs in *listening and language*, I decided to focus on auditory perception for the panel. It was not long before the questions that this line of inquiry suggested, took on their own life and became a full-blown phenomenological research program in auditory experience overall. I soon found myself engaging in and studying acoustic, psychological, linguistic and speech, musicological, and a

whole range of interdisciplinary contributions to audition—including some early engineering problems referred to in the first edition via Georg von Békésy and the problem of sensory inhibition.

So, even before the first edition of *Listening and Voice*, I had begun to publish some preliminary results. The panel on perceiving persons took place in 1966 and my contribution, “On Perceiving Persons,” with two other pieces, “Listening” (coauthored with Tom Slaughter) and “God and Sound,” appeared as early as 1970 in the *International Philosophical Quarterly*, followed by, “Some Auditory Phenomena,” in *Philosophy Today*, 1973. Five sound studies published from 1970 to 1973 were then collected for my second book, *Sense and Significance* (Duquesne University Press, 1973). From this early research, while it was impossible to include all these entries in the new edition, I have included two pre-*Listening and Voice* examples, “Auditory Imagination” and “Listening,” from *Sense and Significance*.

The initial reception to *Listening and Voice* did include some targeted usual suspects, philosophers and humanities readers, and a very large number of reviews and some review articles soon appeared. But communications reviewers soon also picked up on its publication as well, followed somewhat more slowly by musicologists. In short, the audience was highly interdisciplinary. I have been amused to see that citations came from persons writing about submarine communications and from others commenting on the unique acoustics in Islamic mosques!

In this new edition, in which the subtitle changes from *A Phenomenology of Sound* to *Phenomenologies of Sound*, the other newly added chapters reflect an itinerary that continued beyond the initial history. “A Phenomenology of Voice,” was originally a keynote address to a conference on musical improvisation at the University of California, San Diego, and was included in my *Consequences of Phenomenology* (SUNY Press, 1986).

By the mid-1970s I had also become interested in a new domain—philosophy of technology. *Technics and Praxis: A Philosophy of Technology* (1979), is often cited as the first English language work on that theme. With a shift of interest to technologies, I did not however abandon my interest in auditory experience, contrarily, with the inclusion of technologies in human experience, the role of *instrumentation* began to take on increased significance. The earliest of my musical phenomenologies of instrumentation, “From Bach to Rock,” was included in *Technics and Praxis* and I have reprinted that piece here as well. And while my interest in the role of instruments in the philosophy of technology often tended toward particular attention to *scientific* instruments, their role in the production of knowledge often could be seen in both comparison and contrast to the role of instruments in producing music. For example, it became obvious that the domi-

nant trajectory in science instrumentation was one that produces *visual* results. And in a secondary, but important sense, most science instrumentation also followed a progressive development—constantly making and inventing new instruments was the norm. Music, the dominant auditory art, utilized instruments that produced sounds. But in contrast to the practices of science, one could favor traditional, or even older instruments as equal to or even over any new ones. Indeed, “From Bach to Rock” deals with, in part, the resistance to new instrumentation. Then, moving from rock to jazz, I have taken some account of the role of the then newly invented saxophone in “Jazz Embodied: Instrumentation,” and then on to other forms of even more contemporary instrumentation, including electronic and synthesized music in “Embodiment, Technologies and Musics,” and also, moving to the experience of auditory prosthetic technologies in “Embodying Hearing Devices.” So, the added phenomenologies of sound follow a long trajectory of interest in the acoustic and the auditory that still persists.

The field, too, has changed. I want to mention here, first some samples that relate closely and with more direct relations to *Listening and Voice*, and then move to more distant studies in recent acoustic and auditory phenomena. Just last year SUNY Press published *Postphenomenology: A Critical Companion to Ihde*, edited by Evan Selinger. In part II, three of the authors refer back to and branch out from *Listening and Voice*. (Two of them, Lenore Langsdorf and Judith Lochhead, were former students on whose dissertation committees I served.) In Langsdorf’s case, the emphasis of her chapter relates to the role of an auditory ontology for communication theory, in her contribution the concreteness of voice balances the tendency to abstraction by some leading theorists; and in Lochhead’s case she has moved to the role of visualizing the musical object and its relation to new modes of scoring and its importance in musicology. Both have pioneered in phenomenological approaches to their respective fields. Trevor Pinch relates his chapter to his own development of “sound studies,” which actually grew out of the earlier patterns of analysis in *science studies*. As one of the inventors of “social constructionism,” Pinch takes the history, sociology and phenomenology of musical technologies to the early development of analog synthesizers. His *Analog Days: The Invention and Impact of the Moog Synthesizer*, with Frank Trocco (Harvard, 2004), is a definitive example of this style of analysis to synthesizer development. I, myself, have learned much from each of these colleagues, in Lochhead’s case since we are colleagues at Stony Brook, with various experiences coteaching graduate seminars; and in collaborations with Pinch both at Stony Brook and internationally in 4/S (Society for the Social Study of Science); and in publications and editorially with Langsdorf.

A different direction, again following sound and its embodiments in both language and musical dance, has been taken by two leading ethno-anthropologists: Steven Feld (with Keith H. Basso) in *Senses of Place* (SAR Press, 1996), traces out the role of auditory-metaphor saturated languages among the New Guinean highlanders who inhabit rain forests where audition necessarily plays an important perceptual role in such an environment. In the case of Steven M Friedson, *Dancing Prophets: Musical Experience in Tumbaka Healing* (University of Chicago Press, 1996) again the role of music and dance is located within a different social role than typical of industrialized societies. In both cases the contrast with dominant visualist emphases in Euro-American cultures provide provocative variations.

Moving now from studies more or less interactive with *Listening and Voice*, one may also take note of the importance of new acoustic and audio technologies. Since 1998, I have been the director of a research program called the Technoscience Research Group within the philosophy department at Stony Brook University. Several of the Visiting Scholars who have spent year long residences with the group have also produced published studies focused on sound. Lars Nyre from Bergen University, Norway, published a 2003 study, *Fidelity Matters: Sound Media and Realism in the Twentieth Century*. Following first the development of radio and recorded media, Nyre follows the changing technology-media histories and phenomenologies through the last century to the present. In a similar vein, Michele Hilmes and Jason Loviglio have done a cultural studies *Radio Reader* (Routledge, 2002) and Michael Bull another on personal stereos, *Sounding out the City* (Berg, 2000). Daniel Fallman, another Visiting Scholar with the technoscience group, Umea University, Sweden, focused on mobile technologies, including mobile telephones, in his *In Romance with the Materials of Mobile Interaction: A Phenomenological Approach to the Design of Mobile Information Technologies* (Umea, 2003), did an analysis of mobile technologies, including audio technologies as well.

Then, chronologically paralleling the development of the technoscience research group, I myself have been engaged in a research program on imaging technologies with a special focus on science instrumentation. While culturally, contemporary science is visual imaging dominant, new approaches from cultural studies and science studies have opened the way to taking audio technologies into account in new and unique ways. A few groups have specifically noted the parallel development of instrumentation in science and art. For example, a multivolume series by Helmar Schram, Ludger Schwarte, and Jan Lazardzig, *Instrumente in Kunst und Wissenschaft* (de Gruyter, 2006, also forthcoming in English) has been published out of the Free University in Berlin. And, in the United States the husband-wife

team of Peter Galison, history and philosophy of science, and Caroline A. Jones, art history, have teamed up with art and science authors in *Picturing Science Producing Art* (Routledge, 1998). Add the collaboration of artist Peter Weibel and science studies anthropologist-sociologist-philosopher Bruno Latour with *Iconoclasm: Beyond the Image Wars in Science, Religion and Art* (MIT Press, 2002) and the field of science/art and their respective instrumentations is seen to expand in most suggestive ways.

I will conclude this preface by turning to some singularly contemporary phenomena that have come to human awareness specifically through new audio technologies. Perhaps the simplest capacity of audio-technology, comparable to optical magnification with lenses of which the history extends back to the beginnings of early modernity, is amplification. Telescopes and microscopes, largely beginning with seventeenth-century use, began to reveal new micros- and macroworlds; amplification technologies, apart from “hearing horns” and interesting architectural “whispering walls” are much more recent. Simple amplification brings into perceptual experience, sounds which without amplification we could not hear, but nevertheless sounds within the frequency ranges we already have within the limits of human audition. Thus oceanic amplification, which brings us whale songs; audio-instruments, which detect and amplify the crunching sounds of Japanese pine tree beetles deep within the bark of now-threatened pines; and amazing varieties of echolocation devices now expand our world of listening.

Yet, since the middle of the last century, the twentieth, several new instrumental capacities have radically transformed the auditory world. One such capacity is the detection of sound waves both below and above the normal hearing ranges of humans—infra and ultrasounds. To make such sounds hearable, however, a second contemporary capacity of the technologies is also needed, capacities that stem from various computer processes simply not available prior to about fifty years ago. I have mentioned whale songs, which while heard by ancient mariners, were not known by them to be sung by whales. Much of the frequencies of those songs, however, are in the infrasound range, too low for us to hear except through technological mediation. Only after these frequencies are “compressed”—the time of the song is compressed, which simultaneously raises the frequency into human hearing range—can we *hear* the technologically mediated and *translated* sounds. Biologists, at first astonished by the complexity and distribution of such animal songs, have now begun to find song behavior much more common than previously thought. Recently, for example, ultrasound male mouse serenades have also been acoustically discovered (see chapter 23). Without both amplification and time compression, humans simply would not be able to hear these songs.

Part of the technical capacity which produces such results lies in the computational ability to change data into images (patterned visual gestalts), or images into data. Artists in particular have realized that such transformations can apply equally to visual and to *auditory images*. Some of the examples in chapter 23 refer to this capacity, but there are hundreds of other examples extant which range from making sound patterns of climate change, to reproducing in compressed time, the rhythms of city life. Written large, just as science seems to produce an infinite set of visual images for virtually all its phenomena—atoms to galaxies are familiar to us from coffee table books to science magazines; so “musics,” too, could be produced from the same data that produces visualizations. This capacity also makes an *artifactual synesthesia* possible. While serving on Daniel Fallman’s dissertation defense in Umea, Sweden, in 2004, I was introduced to a “reality helmet,” which was just such a device. In this case the detected visual signals were translated into audio-presentations and the audio-signals were translated into visual images!

All these are, of course, variations on the “standard” of audiovisual media, but now increasingly also with multimedia technologies. Cinema, the most popular and familiar of these, has long been experimental with both visual and auditory effects. Ligeti’s early cut-and-paste synthesized music was incorporated into Stanley Kubrick’s famous movies; similarly, one should also include also the visual time-compressed *Koyaanisqatsi* of Francis Ford Coppola with the minimalist music of Philip Glass—or the live performances of Glass at the Brooklyn Academy of Music to *Dracula*; or Steve Reich to *Hindenberg*, and one can see and hear the experimental flavors of the contemporary. This new edition of *Listening and Voice*, with its added *phenomenologies of sound* spans some of these phenomena that so change the range and “worlds” of the auditory.

Finally, I need to acknowledge those who have helped make this new edition possible. Adam Rosenfeld has been my primary assistant in preparing the new manuscript. Because some of it was “BC” that is, before computers, scanning, and other technological processes were necessary to bring the expanded manuscript to print preparation stage. His technical expertise made the process much less painful than otherwise would have been the case. Michael Sigrist, too, helped in the preparation of the index. Jane Bunker, editor in chief of SUNY Press, encouraged and pushed the review process along (I thank my anonymous, positive reviewers, too). And, I want to make special note of the now more than two-decade-long collegial and collaborative engagement with Judith Lochhead. It was she who taught me to appreciate many of the contemporary musics I might have otherwise missed; and she also almost single-handedly helped stimulate

musicologists to pay attention to phenomenological approaches. I think we have both benefited from the coteaching experiences that she initiated. My family, Linda and Mark, through this process, in their love of music, have also provided inspiration. My department and university have provided the flexible infrastructure that encourages innovative research programs, and while often taken for granted, must be seen as contributory to the project.



The first edition of *Listening and Voice: A Phenomenology of Sound*, was with the Ohio University Press (1976). Chapters 1 through 16 constitute the first part of the second edition. This new edition adds seven new chapters, phenomenologies of sound, of which chapters 18 and 19 are reprinted from *Sense and Significance* originally published by Duquesne University Press (1973). In the cases of both these books, copyrights reverted to the author when reissues ceased. Chapter 17, as noted previously, first appeared in *Consequences of Phenomenology* (SUNY Press, 1986) is reprinted here with permission of the Press.

Chapter 20 was first published with *Music and Man*, 1, No. 1, 1973, and again in *Technics and Praxis* (Reidel Publishers, 1979) and is reprinted here under the contracted convention that allows an author to reprint within a collection of his own works. Chapter 21, originally printed in *Spontaneous Combustion*, a tenth-anniversary monograph of the Copenhagen Jazz House (2001), is reprinted here with the permission of editor and Jazz House co-founder, Benedicta Pesceli. Chapters 22 and 23 are original to this edition.

This page intentionally left blank.

Introduction (to the original)

I have attempted to put this investigation in as straightforward and simple a fashion as possible. For this reason, although I have undertaken extensive studies in related fields such as the physiology of hearing, acoustics, and musical theory, references to these are implicit.

Except in the introductory remarks the same implicitness remains the case with the giants of the phenomenological tradition. I have forsworn any lengthy discussions of Husserl, Heidegger, Merleau-Ponty, Ricoeur, or Sartre—although all may be seen by the perceptive reader to be lurking beneath the surface.

Moreover, I have also chosen to describe things autobiographically to make the narrative even more straightforward. Because of this I run the risk that the book may be taken as merely autobiographical when its presumption is at least a bit more pretentious. It is intended as a prolegomena to an ontology of listening with suggestions for the implications of a philosophy of sound. In fact, while the style of the illustrations here is autobiographical, the investigations themselves took place over seven years and involved classroom investigation and much intersubjective research. In some instances studies in empirical psychology also suggested inquiry in a more phenomenological vein. Thus the danger of taking the studies as being mere assertions should be avoided. They should be taken as exercises in the application of a stricter phenomenological use of *variations* that have in every instance been cross-checked with other persons' experiences.

It has been my hope that my adoption of this style may gain more than it loses by giving a sense of *doing a* phenomenological investigation and by dealing with it in a language that I have attempted to make as clear as my abilities allow. In the process I may well lose the attention of some who prefer extensive proof texting and multiple footnotes to show the indebtedness

of which I am only too painfully aware. But I also wish to gain what I hope will be a sense of the excitement that can come from getting under way in initiating a phenomenology of listening and voice.

There is one other preliminary problem I wish to point out. To do a phenomenology of sound in *a book is* itself something of a functional “contradiction.” A book is read and its words are seen rather than heard. There are vast differences between hearing voices and reading words; yet the distance between the language embodied visually and that which is heard is sometimes bridged. Sometimes there is a “singing” of voice *in* writing. I have often been shocked at “hearing” a friend’s voice on reading his or her latest article or book. The other sounds through in an auditory adherence to what is ordinarily soundless. The same phenomenon occurs with trained musicians who can “hear” the music they see when reading a score.

These phenomena themselves are not only perplexing but intriguing and must be part of the sense of the investigation. Ultimately, involvement with the world must show itself as well. That will be part of the task of the text and part of the terrain of the investigation itself.

Finally, those sources of explicit and concrete help that made the book possible should be acknowledged. Support for the research came in the forms of Summer Faculty Fellowships awarded by the State University of New York and a Senior Fellowship awarded by the National Endowment for the Humanities in 1972. I wish to thank the many preliminary readers of the manuscript for their suggestions and criticisms. In particular I am grateful to Professors David Carr, Edward Casey, and John O’Neill; and to David Allison, Roger Bell, and Elyse Glass at State University of New York at Stony Brook.

Part I

Introduction

This page intentionally left blank.

Chapter 1

In Praise of Sound

The beginning of man is in the midst of *word*.

And the center of word is in breath and sound, in listening and speaking. In the ancient mythologies the word for soul was often related to the word for breath. In the biblical myth of the creation, God breathes life into Adam, and that breath is both life and word.

Today mythical thought is still repeated in other ways. We know that we live immersed in a vast but invisible ocean of air that surrounds us and permeates us and without which our life must necessarily escape us. For even when we humans wander far from the surface of the earth to that of the moon or deep into the sea, we must take with us packaged envelopes of air that we inhale and exhale. But in the words about breath there lurk ancient significances by which we take in the haleness or health of the air that for the ancients was spirit. From breath and the submersion in air also comes *in-spire*, “to take in spirit,” and on a final *ex-halation* we ex-(s)pire, and the spirit leaves us without life. Thus still with us, hidden in our language, is something of the ontology of Anaximenes who, concerning the air, thought, “As our souls, being air, hold us together, so breath and air embrace the entire universe.”¹

But the air that is breathed is not neutral or lifeless, for it has its life in *sound* and *voice*. Its sound ranges from the barely or not-at-all noticed background of our own breathing to the noises of the world and the singing of word and song among humans. The silence of the invisible comes to life in

sound. For the human listener there is a multiplicity of senses in which *there is word in the wind*.

From a thoroughly contemporary source the importance of soundful significance may be discerned today as well. This new interest arises from various fronts of the contemporary sciences and philosophies. In philosophy there can be no doubt that questions of language and speech have been of great if not dominant importance in current philosophy. If, on the one side, that interest has been primarily in logic and syntax, as is the case with the Anglo-American philosophies, and, on the other side, the interest has been the birth of meaning in speech in Continental thought, the question of word has been a central concern of the twentieth century. There has also arisen and flourished a whole series of linguistic sciences that relate to the question of word: phonetics, semiology, structural and generative linguistics, and the diverse schools of semantics.

Yet after the critical thinker has studied and read through these disciplines with their admittedly brilliant advances, there can remain a doubt that everything essential has been noted. For there appears in the very proliferation of disciplines addressed to the question of word a division that leaves word disincarnate. On the one side, are the disciplines that address the structure, the form, the mechanics of language. Its surface and depth rules that produce significances are conceived of almost without the sense of enactment by a speaker in what may be termed a "mechanics of language." The philosopher, concerned with comprehensiveness, must eventually call for attention to the *word as soundful*. On the other side, the sciences that attend to the soundful, from phonetics to acoustics, do so as if the sound were bare and empty of significance in a physics of the soundful. And the philosopher, concerned with the roots of reflection in human experience, must eventually also listen to the *sounds as meaningful*.

There is a third source of the contemporary interest in sound and listening which, while so familiar as to be taken for granted, includes within it a subtle and profound transformation of experience itself as our capacities for listening are changed by technological culture. Its roots lie in the birth of the electronic communications revolution. Through this revolution we have learned to listen farther than any previous human generation. The telephone, the radio, and even the radio telescope have extended the range of our hearing as never before. It has also made technologically produced sound pervasive, as the Beatles and Beethoven alike blare forth from the living-room stereo.

But above all, the electronic communications revolution has made us aware that once silent realms are in fact realms of sound and noise. The ocean now resounds with whale songs and shrimp percussion made possi-

ble by the extension of listening through electronic amplification. The distant stars, which perhaps are not so thoroughly in a “harmony of the spheres” of the Pythagoreans, nevertheless sputter in the static of radio-astronomy. In our urban environments noise pollution threatens the peace of mind that we now wishfully dream of in terms of quieter eras.

It is not merely that the world has suddenly become noisier, or that we can hear farther, or even that sound is somehow demandingly pervasive in a technological culture. It is rather that by living with electronic instruments our experience of listening itself is being transformed, and included in this transformation are the ideas we have about the world and ourselves.

If we grant that the origins of science lie with the Greeks, aided by the sense of mastery implied in the human role of cocreator with the Hebrew God, there remains a distinct distance from both Greek science and Hebrew theology in the rise of technology. Contemporary science is *experienced* as embodied in and through instruments. Instruments are the “body” that extends and transforms the perceptions of the users of the instruments. This phenomenon may be considered apart from the usual considerations of the logic of the sciences, of the inner language of science in mathematics, and it may be investigated in terms of the experience through technology of the worlds, others, and myself.²

What is of special interest to the thoughtful listener is then the way instruments, particularly those of the electronic era, introduce ways of listening not previously available. If one playfully turns to a speculative consideration of the role of instrumentation as a means of embodied experience in relation to the rise of modern science, a hypothesis suggests itself. Whether by historical accident or a long-held and traditional preoccupation with vision, the new scientific *view* of the world began with equally new instrumental contexts made possible by the emerging technologies of lens grinding and a concern with optics. Galileo’s moons, never before seen, are *experienced through* the embodying and extending instrument of the telescope. The universe comes into view, is *observed* in its ever-extending macrocosm, through the instrument. It does not make any essential difference in the phenomenon of the transformed experience whether the discovery follows and confirms a speculation or initiates and inaugurates a new view of things. In either case what was previously unseen occurs within experience itself. The same occurs under the gaze of the microscope. A mini-world never before seen even if its existence had been suspected unfolds with a wealth and richness of animals, plants, cells, and microbes not dreamed of in the theoretical imagination that preceded the perception. Thus with increasingly passionate excitement humankind became more and more entranced with this extension of its vision.

Subtly, however, the extension of vision not only transformed but *reduced* humankind's experience of its newly found domains. For the picture of the world that began to unfold through the new instrumentation was essentially a *silent* world. The macrocosmic explosions of the stars and the microcosmic noise of insects and even of cells had not yet reached the human ear. If today we know that this silence was not a part of the extended but reduced world of early modern science, it is in part due to the later development of another means of embodiment through electronic instruments. What was first seen was later given *voice*.

In the gap between optics and electronics in this speculation, the sense of the world moved from the once silent Galilean and Newtonian universe to the noisy and demanding universe of today. But almost by rebound the intrusion of sound perhaps reveals something about our previous way of thinking, a thinking that was a viewing, a *worldview*. We have discovered a latent, presupposed, and dominant visualism to our understanding of experience. If on the popular front it has taken those concerned with media, such as Marshall McLuhan and Walter J. Ong, to point this out for contemporary consciousness, it is because this visualism has long been there for us to see had we but the reflective power to discern it.

This visualism may be taken as a symptomatology of the history of thought. The use and often metaphorical development of vision becomes a variable that can be traced through various periods and high points of intellectual history to show how thinking under the influence of this variable takes shape.

The visualism that has dominated our thinking about reality and experience, however, is not something intrinsically simple. As a tradition it contains at least two interwoven factors. The first is more ancient and may be thought of as an implicit *reduction to vision* whose roots stem from the classic period of Greek philosophical thought. Its source lies not so much in a purposeful reduction of experience to the visual as in the glory of vision that already lay at the center of the Greek experience of reality.

In contemporary philosophy it has been Martin Heidegger who has made us most aware of the deeper roots of the vision of the Greeks. Through his radical analysis of the question of Being, Greek thinking itself emerges as the process of allowing Being to "show forth" as the "shining" of *physis*, of the "manifestation" of Being as a "clearing," all of which recalls the vibrant *vision* of Being. Heidegger is not alone in this recognition of the intimacy between vision and the ultimately real for Greek thought. Theodor Thass-Thienemann notes, "The Greek thinking was conceived in the world of light, in the Apollonian visual world . . . The Greek language expresses this identification of 'seeing' and 'knowing' by a verb which means in the

present *eidomai*, 'appear,' 'shine,' and in the past *oida*, 'I know,' properly, 'I saw.' Thus the Greek 'knows' what he has 'seen.'"³ Even the Greek verb meaning "to live" is synonymous with "to behold light."⁴ Before philosophy and deep in the past of Greek experience the world is one of vision. In this sense visualism is as old as our own cultural heritage.

But with the development of philosophy, more with its *establishment* in the Academy and the Lyceum, the preference for vision expressed in the wider culture begins to become more explicit. Visualism arises with a gradual distinguishing of the senses. One of the earliest examples lies in the enigmatic claim of Heraclitus that "eyes are more accurate witnesses than ears."⁵ Not being given a context for the fragment, it is of course quite difficult to discern what Heraclitus meant. He could have meant that to see something happen in the flesh is more accurate than to hear of it through gossip. But even if this is not what he had in mind, the relation of sight and accuracy already appears to be established. Experientially it is not at all obvious that eyes are more discriminating than ears.

Even the ordinary listener performs countless auditory tasks that call for great accuracy and discrimination. In physical terms the mosquito buzzing outside the window produces only one-quadrillionth of a watt of power; yet one hears it with annoyance, even if one can't see it. And the moment trained listening is considered, feats of discrimination become more impressive. The expert auto mechanic can often detect the difficulties in an engine by sound, although when it has been taken apart the play in the bearings may be difficult to see. And in the paradigm of disciplined listening, the musician demonstrates feats of hearing that call for minute accuracy. The listener to the subtlety of Indian music with its multiple microtones discovers an order of extremely fine auditory embroidery.

But whether or not Heraclitus stated a preference for vision which may already conceal a latent inattentiveness to listening, Aristotle, at the peak of academic philosophy, notes, "Above all we value sight . . . because *sight is the principle source of knowledge* and reveals many differences between one object and another."⁶ Here is a clearer example of a preference for vision and emerging distinctions among the senses.

Several features of this text stand out. First, it is clear that Aristotle notes that the valuation of sight is already something common, taken for granted, a tradition already established. Second, there is again the association of sight with differences and distinctions that may be the clue to a latent inattentiveness to listening. But, third and most important, the main thrust of Aristotle's visualism lies in the relation between sight and *objects*. The preference for vision is tied to a metaphysics of objects. Vision already is on the way to being the "objective" sense.

Once attention to the latent visualist tradition of philosophy is made concerning the intimate relation between light imagery and knowledge, a flood of examples comes to mind. For visualism in this sense retains its force in English and in most related Indo-European languages. Only the briefest survey shows the presence of visual metaphors and meanings. When one solves a problem he has had the requisite *insight*. Reason is the *inner light*. There is a *mind's "eye."* We are *enlightened* when informed by an answer. Even the lightbulb going on in a cloud over the cartoon character's head continues the linkage of thought with vision.

Less obvious but equally pervasive are the terms which, while they have lost the immediacy of light imagery, retain it at the root meaning. "Intuition" comes from the Latin *in-tueri*, "to look at something." Even "perceive" is often implicitly restricted to a visual meaning. Vision becomes the root metaphor for thought, the paradigm that dominates our understanding of thinking in a reduction to vision.

Philosophy and its natural children, the sciences, have often blindly accepted this visualism and taken it for granted. It is not that this tradition has been unproductive: the praise of sight has indeed had a rich and varied history. The rationality of the West owes much to the *clarity* of its vision. But the simple preference for sight may also become, in its very richness, a source of the relative inattentiveness to the global fullness of experience and, in this case, to the equal richness of listening.

Even within the dominant traditions there have been warnings in the form of minority voices. Empedocles called for a democracy of the senses.

Come now, with all your powers discern how each thing manifests itself, trusting no more to sight than to hearing, and no more to the echoing ear than to the tongue's taste; rejecting none of the body's parts that might be a means to knowledge, but attending to each particular manifestation.⁷

And from the very earliest stratum of Greek philosophical thought Xenophanes voiced the note that experience in its deepest form is global: "It is the whole that sees, the whole that thinks, the whole that hears."⁸

Were, then, the dominant visualism which has accompanied the history of thought a mere inattention to listening, the praise of sound which may begin in its own way in the twentieth century would be but a corrective addition to the richness of philosophical vision. And that itself would be a worthwhile task. But the latent reduction *to* vision became complicated within the history of thought by a second reduction, a reduction *of* vision.

The roots of the second reduction lie almost indiscernibly intertwined with those arising from the preference for vision; the reduction *of* vision is

one which ultimately separates sense from significance, which arises out of doubt over perception itself. Its retrospective result, however, is to diminish the richness of every sense.

For the second reduction to occur there must be a division of experience itself. This division was anticipated by two of the Greeks, Plato and Democritus, who were opposed in substance but united formally in the origin of Western metaphysics. For both, the ultimately real was beyond sense, and thus for both, sense was diminished. Both “invented” metaphysics.

This invention was the invention of a perspective, a perspective which was ultimately *imaginative*, but which in its self-understanding was the creation of a “theoretical attitude,” a stance in which a constructed or hypothesized entity *apart from all perceptual experience* begins to assume the value of the ultimately “real.” With Democritus the occasion for the invention of metaphysics came with the idea of the *atom*. The atom is a thing reduced to an *object*. Rather than a thing that shows itself within experience in all its richness, the atom is an object which has ‘primary’ qualities to which are added as effects ‘secondary’ qualities that are ‘caused by’ the primary qualities. Thus, too, *is explanation* born. The task of metaphysics is to “explain” how the division it introduces into the thing is overcome by a theory of complex relations between the ‘primary’ and the ‘secondary’ qualities.

Democritus’s atoms are no longer things, they are “objects” which, while they may *seem* to possess the richness of things, at base are “known” to be poorer than things. Democritus’s atoms, according to Aristotle, possess only *shape, inclination* (direction of turning), and *arrangement*. But note what has happened to sense: “visually” the atoms are “really” colorless, and insofar as they are colorless in “reality” they are “beyond” sense *in principle*. This is a leap which propels Democritus onto a path prepared for but never taken by his predecessors. Anaxagoras’s “seeds,” which were the predecessors of atoms, were *in practice* invisible, because they were too small for our eyes to see. What was lacking was a means of bringing them into view. But even though our powers are limited, for Anaxagoras “appearances are a glimpse of the unseen.”⁹

But with the Democritean atom which is *essentially* colorless, what sense “gives” is placed under an ultimate suspicion. For Democritus it is “by convention that color exists, by convention sweet, by convention bitter.” Knowledge is divided into sense, and what is not yet named but which is essentially different from sense. “Of knowledge there are two types: the one genuine, the other obscure. Obscure knowledge includes everything that is given by sight, hearing, smell, taste, touch; whereas genuine knowledge is something quite distinct from this.”¹⁰ This momentous turning was not taken without some doubt. Democritus heard this doubt in a voice given to

the senses, "Ah, wretched intellect, you get your evidence only as we give it to you, and yet you try to overthrow us. That overthrow will be your downfall."¹¹ Nor is it ever clear that the "overthrow" succeeded completely. Even the atom retained one, though diminished, *visual* attribute in its *shape*. The preliminary result of the "invention" of metaphysics was the diminution of vision in its essential possibilities.

Plato in his own way made the same "invention." But Plato's version of the "invention" of metaphysics was, if anything, more complete than Democritus's. If Democritus's atoms retained one visible predicate, Plato's ultimate "reality," the Idea of the Good, in itself contained none but was presumably known only to the mind or intelligence. There does remain an *analogy* with the sensible, and that analogy is again visual. The Idea of the Good is "like" the sun in the visible realm. "It was the Sun, then, that I meant when I spoke of that offspring which the Good has created in the visible world, to stand there in the same relation to vision and visible things as that which the Good itself bears in the intelligible world to intelligence and intelligible objects."¹² But Plato steadfastly maintained that this was merely an analogy: "light and vision were thought to be as like the Sun, but not identical with it . . . to identify either with the Good is wrong,"¹³ because the distinction between the visible or sensible and the intelligible that founds the doctrine of forms of Ideas has already separated sense from reason. The sensible realm in its "likeness" or analogy to the purely intelligible realm of the Ideas becomes a "representation" that indicates what cannot be sensed. In the notion of imitation, mimesis, and representation lies the direction that is counter to that of the polymorphic embodiments of experience, and lays the antique basis for the more modern forms of the dualism of experience that pervade the contemporary era. The ancient sources of the double reduction of experience in visualism did not become clear or mature until the opening of the modern era. Modern visualism as a compounded reduction of experience is clearly notable in the work of Descartes where both the Democritean and Platonic anticipations meet to form the basis of modern visualism. Descartes unites and preserves the ambiguities of the diminution of the senses in his praise of the *geometrical method*. For Descartes the light and visual imagery has become metaphorical in a rather perfunctory sense: "Having now ascertained certain principles of material things, which were sought, not by the prejudices of the senses, but by the *light* of reason, and which thus possess so great evidence that we cannot doubt their truth, it remains for us to consider whether from these *alone* we can deduce the explication of all the phenomena of nature."¹⁴ Thus in the rise of modern metaphysics there is retained the echo of a distrust of the senses and a corresponding faith in reason as an invisible, imperceptible realm of truth.

With Descartes the progression of the diminution of sense continues, and the object is now reduced to its geometric attributes: he further reduces the Democritean atom. “The nature of the body consists not in weight, hardness, colour and the like, but in extension alone it is in its being a substance extended in length, breadth, and depth.”¹⁵ Here the Democritean anticipations of a doctrine of “primary” and “secondary” qualities take the form of being defined in geometric terms. Extension is “primary” and all other qualities are “secondary” or derived.

But Descartes repeats the Democritean ambiguity. While claiming that “*by our senses* we know nothing of external objects beyond their figure, magnitude, and motion,”¹⁶ his ultimate aim is a total denial of sense.

But, since I assign determinate figures, magnitudes, and motions to the insensible particles of bodies, *as if I had seen them*, whereas I admit that they do not fall under the senses, some one will perhaps demand how I have come by my knowledge of them. To this I reply, that I first considered . . . all the clear and distinct notions of material things that are to be found in our *understanding* . . . which rules are the principles of geometry and mechanics, I judged that all the knowledge man can have of nature must of necessity be drawn from this source.¹⁷

In spite of this extrapolated claim the now geometrically reduced object even at its insensible level retains certain “abstract” visual properties. However, the “real” object is now thought to be a bare and reduced object distinctly different from the rich thing found in experience.

What Descartes accomplishes, here using what happens to vision as a symptom for what happens to experience overall, is a division of experience into two realms so that one region of experience is made to rule over all others. The reduced abstract object (extended object) becomes “objective” and its appearance within perceptual experience with the significant exception of those ghostly remaining visual qualities becomes “subjective.” Simultaneously reason, understanding, the geometrical deductive process, become disembodied as “pure” acts of mind.

Descartes’s counterpart, John Locke, disagreed that the source of clear and distinct ideas was the understanding—it was rather experience—but in formulating the grounds of empiricism Locke preserved the ancient distrust of perception in a new way. Seeming to take seriously and to take account of sense experience, Locke ended by reducing it to a sense automatism that again separated knowledge from things.

Locke, as did Descartes, perfunctorily maintained the metaphor between seeing and understanding. “The understanding, like the eye, whilst

it makes us see and perceive all other things, takes no notice of itself; and it requires art and pains to set it at a distance, and to make it its own object.”¹⁸ But in Locke’s case, if the metaphor was to be extended, it was not the eye but an outside influence which provided its own objects. Thus the classical empiricist thesis:

Let us suppose the mind to be, as we say, white paper, void of all characters, without any ideas; how comes it to be furnished? Whence comes it to be that vast store, which the busy and boundless fancy of man has painted on it with an almost endless variety? Whence has it all the materials of reason and knowledge? To this I answer in one word, from EXPERIENCE.¹⁹

The door is opened in this thesis to things and the richness of experience, but Locke so quickly borrowed from Descartes the notion of clear and simple ideas that mundane experience was immediately bypassed for what became empiricist atomism. Locke believed, in an echo of the analytic and geometric prejudice, that what was primitive in experience had to be the simple, and thus the simple and already analyzed idea was in effect the object that was immediately before the mind in experience, “that term which, I think, serves best to stand for whatsoever is the object of the understanding when man thinks.”²⁰ But such simples are better called *concepts* than perceptions, whereas perception for empiricism becomes the result of an unfelt and unexperienced pointillism of abstract qualities.

Locke paused only briefly before the things. “Though the qualities that affect our senses are, in the things themselves, so united and blended that there is no separation, no distance between them,”²¹ he did not hesitate to immediately conclude that “yet it is plain the ideas they produce in the mind enter by the senses *simple* and *unmixed*.”²² These ideas, which are simple and unmixed, are the “atoms” of sensory qualities, “abstract” qualities apart from any thing. “Thus we come by those *ideas* we have of yellow, white, heat, cold, soft, hard, bitter, sweet, and all those which we call sensible qualities.”²³ That no one has ever perceived a disembodied white did not seem to trouble Locke, and the empiricist tradition to this day debates the way we build up objects, and things from these simple ideas become “sense data.”

Nor is this the end of the Lockean version of the reduction of the thing. Locke specifically enunciated the previously implicit doctrine of primary and secondary qualities, that is, of the various atoms of qualities some are privileged and others are mere effects of the privileged qualities.

Primary qualities were thought by Locke to be qualities *of* the material object (the reduced object). “Qualities thus considered in bodies are. First,

such as are utterly inseparable from the body in what estate soever it be.”²⁴ And these qualities remain cartesian and visual, although they are more complex than those allowed by Descartes (and allowing one quality which Locke thought belonged to *tactile* perception as well): “These I call *original* or *primary qualities* of body, which I think we may observe to produce simple ideas in us, viz. solidity, extension, figure, motion or rest, and number.”²⁵ Secondary qualities are those “which in truth are not in the object themselves, but powers to produce various sensations in us by their primary qualities.”²⁶ Thus Locke repeated in essential outline the metaphysical division of the thing that results in its reduction.

This division was already enough to establish the need for empiricism to face the problem of how the thing is built up from its simple atoms, but a second dimension to the division was also affirmed by Locke, the atomism of the senses. It is quite clear that in his interpretation of the already extant tradition of five senses, the senses had now become more “clear and distinct” so that some qualities enter experience from one sense only, and others enter from the other senses. Thus the thing remains, in itself, an object of primarily visual—spatial attributes to which in the mystery of experience are “added” the various simple and “subjective” ideas of other qualities. Both the thing and experience remain under the limitation of the double reduction.

This progressive march of reductionism in philosophy is more than a mere visualism which stands as its symptom. It is a tendency which lies more deeply in a certain self-understanding of philosophy. On a surface level, and again symptomatically, a visualism can be called into question by pointing up consequences that lead to the inattention to important dimensions of experience in other areas, here, in particular in an inattention to listening. Not only are sounds, in the metaphysical tradition, secondary, but the inattention to the sounding of things has led to the gradual loss of understanding whole ranges of phenomena that are there to be noted.

What is being called visualism here as a symptom is the whole reductionist tendency, which in seeking to purify experiences belies its richness at the source. A turn to the *auditory dimension* is thus potentially more than a simple changing of variables. It begins as a deliberate decentering of a dominant tradition in order to discover what may be missing as a result of the traditional double reduction of vision as the main variable and metaphor. This deliberate change of emphasis from the visual to the auditory dimension at first symbolizes a hope to find material for a recovery of the richness of primary experience that is now forgotten or covered over in the too tightly interpreted visualist traditions.

It might even be preliminarily suspected that precisely some of the range of phenomena at present most difficult for a visualist tradition might

yield more readily to an attention that is more concerned with listening. For example, symbolically, it is the *invisible* that poses a series of almost insurmountable problems for much contemporary philosophy. “Other minds” or persons who fail to disclose themselves in their “inner” invisibility; the “Gods” who remain hidden; my own “self,” which constantly eludes a simple visual appearance; the whole realm of spoken and heard language must remain unsolvable so long as our seeing is not also a listening. *It is to the invisible that listening may attend.*

If these are some of the hopes of a philosophy of listening and voice, there remains within philosophy a strong resistance to such a task. For philosophy has not only indicated a preference for the visual and then reduced its vision from the glowing, shining presence of *physis* to its present status as the seeing of surfaces as combinations of atomized qualities, but it has harbored from its classic times a suspicion of the *voice*, particularly the sonorous voice. Although there may be a certain touch of irony in the *Republic* of Plato (who could be a more subtle rhetorician than Socrates?), the intimation of danger in poetry, dramatic recitation, and even in certain music remains. There is in philosophy a secret tendency toward a morality of sparseness, which today is typified by a preference for desert landscapes. Socrates noted, “It strikes me, said I, that without noticing it, we have been purging our commonwealth of that luxurious excess we said it suffered from.”²⁷

In the wider Greek culture, however, the Apollonian love of light was balanced by the Marsyasian love of sound. The tragedies spoke in sonorous voices through the *persona*, or “masks,” which later are held to mean also *per-sona* or “by sound.” Nietzsche, who much later placed into a dialectic the Apollonian and the dark and furious Dionysian, affirmed that one must also accept a “god who dances” as well as the stability of Apollonian form. Yet in spite of the apparent domination of a new reduced Apollonian visualism, there is also another root of our Western culture that takes as primary a version of a “god who dances” with the movement and rhythm of sound.

That tradition is not that of philosophy but that of the Hebrew theology of the imagery of word and sound. The primary presence of the God of the West has been as the God of Word, YHWH. “And God *said*, let there be ———.” The creative power of the Hebrew God is *word*, which is spoken forth as power: *from word comes the world*. And although God may hide himself from the eyes, he reveals himself in word, which is also event in spite of the invisibility of his being. Human life, too, as the word-breath that unites the human with others and the gods is a life in sound. But if the world is devocalized, then what becomes of listening? Such has been a theological question that has also pervaded our culture.

A theology is not a philosophy, and what is needed is not a revival of theology, not even a secular theology. For so long as the gods remain silent—and if they are dead they have fallen into the ultimate silence—no amount of noise will revive them. But if they speak they will be heard only by ears attuned to full listening. For what is needed is a *philosophy* of listening. But is this a possibility? If philosophy has its very roots intertwined with a secret vision of Being that has resulted in the present state of visualism, can it listen with equal profundity? What is called for is an ontology of the auditory. And if any first expression is a “singing of the world,” as Merleau-Ponty puts it, then what begins here is a singing that begins in a turn to the auditory dimension.

But while such a symptomatology has its tactical uses, a deliberate de-centering of visualism in order to point up the overlooked and the unheard, its ultimate aim is not to replace vision as such with listening as such. Its more profound aim is to move from the present with all its taken-for-granted beliefs about vision and experience and step by step, to move toward a radically different understanding of experience, one which has its roots in a *phenomenology* of auditory experience.

This page intentionally left blank.

Chapter 2

Under the Signs of Husserl and Heidegger

The examination of sound begins with a phenomenology. It is this style of thinking which concentrates an intense examination on experience in its multifaceted, complex, and essential forms. Nothing is easier than a “phenomenology,” because each person has her experience and may reflect on it. Nothing is more “familiar” than our own experience, and nothing is closer to ourselves. Potentially anyone can do a “phenomenology.”

But nothing is harder than a phenomenology, precisely because the very familiarity of our experience makes it hide itself from us. Like glasses for our eyes, our experience remains silently and unseeingly presupposed, unthematized. It contains within itself the uninterrogated and overlooked beliefs and actions that we daily live through but do not critically examine.

There is also a purposeful naïveté to phenomenology in regard to experience as it “returns” to that experience. But that naïveté is not a first or easy one. It is a second naïveté that arises out of a critical and controlled discipline of investigation. The first task of phenomenology is to replace the easy naïveté of ordinary reflection with the difficult second naïveté of phenomenology proper.

Behind the stance of phenomenology proper with its own rigorous naïveté there stands a history guided primarily by the philosophies of Edmund Husserl and Martin Heidegger. For my purposes I shall take these two founders of phenomenological investigation to belong to the same style of thought, although they both started from different questions. Husserl will be

the guide for what may be called *first phenomenology*, while Heidegger will be the guide for *a second phenomenology*.

First phenomenology, initiated by Husserl, is precisely the working out of both a method and a field of study. As a method, self-consciously developed, the Husserlian phenomenology is one which is dominated by a highly technical language and set of intellectual machinery. *Epoché*, *the phenomenological reductions*, *bracketing*, and the various terms that go with Husserl are to be here viewed as a means of gradually approximating a certain stratum of experience. It is a beginning which, through both the deconstruction of taken-for-granted beliefs and the reconstruction of a new language and perspective, becomes a prototype for *a science of experience*.

Second phenomenology begins where first phenomenology leaves off. It takes for granted the attainments of phenomenological method in its most radical sense and directs its questions to both an extension and a deepening of the formal ontologies of Husserl toward a fundamental ontology of Being. Its aim is that of a hermeneutic and existential philosophy.

But if the beginning is one that opens as a “science” of experience and later as second phenomenology leads into the question of “existential” language, there remains in both phenomenologies a sense of learning where one feels even as he enters a new language that he has known it all along. Breaking with the easy familiarity of experience, deliberately putting it at a distance, leads to a return of enriched significance again “familiar” but also subtly changed. Phenomenology allows us to belong to our experience again but hopefully in a more profound way.

One secret of the singleness of the way between first and second phenomenology lies in the distance that emerges between the *center* of experience and things and the *horizon*. For Husserl the center of attention and of all experience is *intentionality*, that essence of experience to be directed toward, to be “aimed” at. And in first phenomenology the concern is to take note of, to describe, and analyze the ways that directedness takes place in both language and perceptual and imaginative experience. The things that are intended and the acts by which their meanings are constituted occupy first phenomenology centrally.

Nor are the things of the world ignored in second phenomenology, but once the center is discovered, the way is also opened “outward” toward limits and horizons. It is increasingly this question that animates second phenomenology and is the source of its at first seemingly odd language. But the unity that lies between first and second phenomenology can be concretely discovered only along the way. And one does not begin with the end.

There is a preliminary and simple way in which the relation between the two guiding figures of phenomenology can be understood, however. "To the things themselves"¹ was the worthy motto of the Husserl who meditated on *epoché*, that turning of thought that creates phenomenology. The problem is one of beginnings; but that has been a perpetual problem for philosophers, because a beginning is always made in the midst of that which has already begun. To begin anew therefore calls for a new way of getting to the things and a new way of expressing that turn. Thus the beginning is one that is a certain struggle with language.

The strategy for beginning, in Husserl's case, was one that called for the elaboration of a step-by-step procedure through which one viewed things differently. His model was one of analogy to various sciences, often analytic in style; thus he built a methodology of steps: *epoché*, the psychological reduction, the phenomenological reduction, the eidetic reduction and the transcendental reduction. At the end of this labyrinth of technique what was called for was a phenomenological attitude, a perspective from which things are to be viewed.² In this, first phenomenology operated like a science and is in the first instance *a statics* of experience.

Historically it was once, after all, strange and unnatural to inhabit the imaginary standpoint in the Copernican view of the earth that called for an observer to imaginatively place himself "outside" the solar system and see an earth rotate around the sun in contrast to the earthbound "first" or naive view that looked outward only to the sun circling the earth. But once the new viewpoint was made intellectually inhabitable, ever new discoveries became possible.

There is also a quality of new frameworks which, once having been learned, renders the once-necessary "machinery" not only easily operable but makes it seem almost unnecessary. Once this language is truly learned, it need not be lived literally, since the way of seeing is the attainment. Thus those who followed Husserl, for the most part, abandoned the mechanism of the scaffolding and developed a more existential language with the intention of dealing with the edifice itself. Such was the case with Heidegger who implicitly follows Husserl's steps without explicitly noting each step of the method. The active attempt to grasp "the things themselves" becomes a "letting be" of the phenomena to "show themselves from themselves."³

Yet despite the connotations of ease, this new version of *epoché* turns out to be equally difficult. To let the *things* speak, to show themselves, calls for an "act" of special restraint on the part of the seeker which, in the case of Heidegger, is the gradual unlayering of the deeply entrenched traditions of thought that continue to enmesh the things themselves in the way they may

be viewed or heard. Thus the “destruction of the history of ontology” is very much a part of the new *epoché* of second phenomenology. It understands that experience cannot be questioned alone or in isolation but must be understood ultimately in relation to its historical and cultural embeddedness.

The distance and relation between first and second phenomenology are reflected in the preliminary results of each. First phenomenology often yields an early appreciation of the *richness* and complexity of experience. But second phenomenology in pursuing that richness discerns in the sedimentation of our traditions of thought an essential embedment in *history* and *time* of experience itself. For while the first word of phenomenology is addressed to the nearness of experience as a philosophy of presence, second phenomenology is a rebound that opens the way to a reevaluation and re-examination of the very language in which our experience is encased and by which it is expressed. The phenomenology of essence, structure, and presence in Husserl leads to the phenomenology of existence, history, and the hermeneutical in Heidegger.

But in actuality the opening to the world that is phenomenology is simultaneously both. The rediscovery of the richness of experience and its structures is a discovery of the essential embedment of experience in historicity and therefore in the polymorphous flexibility of human being. It is not accidental that historically Heidegger’s *Being and Time* and Husserl’s *Crisis* are the most similar works of the two authors pointing to a convergence of the two phenomenologies.

My purpose here, however, is not to digress into the history of phenomenology but to *do* a phenomenology in the light of its past. By distinguishing two phenomenologies that ultimately belong together, a movement is initiated that begins in *approximations*. I shall begin the inquiry in a Husserlian-style first phenomenology and by approximations move toward a more existential philosophy of listening and voice.

This beginning in approximations itself reflects the historical movement of phenomenology in that the first approximations are “abstract” and not fully existential. Yet it is precisely this tendency to accept certain “abstractions” about experience that is closest to the sedimented traditions of thought that I wish to question. The approximations are therefore deliberate. They move away *from* the implicit acceptance of some ordinary and commonsensical understandings of experience toward a more vigorous understanding. This is particularly the case with what may be discerned as a kind of functional “contradiction” in the investigation. In the stylized first phenomenology I deliberately adapt and even heighten the use of a visualist model for phenomenology itself.

Phenomenology itself has not yet fully clarified its own metaphors and paradigms of thinking. This is indicated in the often intense visualism of phenomenology that is purposely employed here. The sense of vision that pervades the recovery of the Greek sense of *physis* by Heidegger has already been noted. "Lighting," "clearing," "shining," "showing," are all revels in light imagery. Even a cursory glance at Husserl's terminology reveals an equally strong visualist terminology. Within intentionality there is the "ray of attention"; the "intuition of essences" is also visual; his adaptation of Greek terms such as *eidos* continues the Husserlian visualism.

The purpose of pointing up this visualist habit in phenomenology is not, however, to open the door to any later antivisualism. The move to separate the senses into discrete faculties and to divide properties categorically among them is an empirical notion, not a phenomenological one. In fact, to the contrary, through concentrating on auditory experience, a reevaluation of all the "senses" is implied. For the first gain of phenomenology in regard to sensory experience is a recovery and reappreciation of the fullness and richness and of the global character of experience. The very notion of an auditory dimension is problematic for phenomenology.

But a purposeful selective focus on auditory experience does, by its very distortion of the primary global character of experience, show something. Such a selective focus functions regionally like a special *epoché* by creating a specified region of focus. Shifting from an ordinary and taken-for-granted paradigm of thought and focus on auditory experience simultaneously allows us to take note of what often goes unnoted and thus also gives us a fresh sense of experience; but this shift also reveals by rebound something about the traditions of interpretation in which our experiences are embedded. Such is the *dialectic* of the two phenomenologies.

For example, there is an old and deeply held tradition that vision "objectifies," and, contrarily but not so widely noted, there is also a tradition which holds that sound "personifies." Phenomenology in its dialectic between experience and language calls for the reexamination of these traditions. Its inquiry displaces the tradition momentarily from its ground in experience.

I take it that this displacement is, in effect, a tactic often used in a different way by Husserl himself, in what may be thought of as a heuristic use of language. By using Cartesian language, for example in the *Cartesian Meditations*, he attempts to overcome Cartesianism from within. The same may be said of Husserl's use of empiricist terminology in the internal time lectures. But there is also a danger in using this tactic, because it calls for a double level of reading. However, by beginning with a familiar mode of

approach the gain may be one of a certain “borrowed” clarity that could otherwise be gained only painfully.

But the acceptance of an accepted style of thinking also has its more radical aim. Phenomenology, in making “common sense” or, better, mundanity, thematic, also calls it into question. It “relativizes” common sense. On one level it is simple to recognize that the common sense of the twentieth century is quite different from that of the fourteenth: Who today would simply accept angels or demons as belonging to the daily human experience? Or, for that matter, who today would even be too sure of the entities so often listed as certain in G. E. Moore’s approach to common sense? Rather, the question is one of how such common sense or ordinary experience is built up or sedimented.

Such relativism, better recognized in the historical, social, and anthropological sciences than in philosophy, must be taken apart and resorted. Thus to begin by accepting what the “ordinary speaker” accepts is from the beginning nonphenomenological. What Husserl called for in the beginning was the suspension (*epoché*) of the “natural attitude,” for a setting aside of certain taken-for-granted beliefs. But such a setting aside of beliefs was not to be a reduction of experience, it was to be a reduction of certain “pre-suppositions” about experience.

Not only is “common sense” to be gradually set aside with certain of its sedimented “beliefs,” but setting aside the usual use of the sciences, which is at once easier and harder to do, must also be accomplished. This is easy to do in one respect: one merely *excludes* all direct knowledge of physics, physiology, empirical psychology, and so on. Such sciences do not “prove” anything for the phenomenologist, at least in the way they are usually taken. Yet the exclusion of the sciences is harder to do in respect to the most essential part of the Husserlian strategy, which is the temptation to lapse into what I shall call here the metaphysical urge to explain rather than describe.

In a sometimes ironic way, however, this very strategy leads to a new appreciation of the sciences, at least in their often implicit and covered-over “phenomenologies.” For example, far more profoundly than many psychologies and philosophies, physical studies in auditory spatial perception have more often been open to what experience *can* show rather than what it is *supposed* to show.

Ultimately, the Husserlian search for a “pure” phenomenology is not so much the exclusion of “common sense” and of science as it is the gradual discovery of the possibilities of a genuinely *descriptive ontology*. First phenomenology calls for a thorough reinterpretation of common sense and science from its own insights. The unfortunate belief that phenomenology

is thus “antiscientific” or even counter to ordinary experience is a confusion held equally by some phenomenologists and those who would maintain that science is impossible without its “Cartesian metaphysics.” But this is a connection that is not considered as essential by other phenomenologists perhaps more thoroughly cognizant of the sciences.

Until this confusion is sorted out—and it can be sorted out only *after* the phenomenological perspective is clearly gained—there must remain within all proximate parts of first phenomenology a certain polemic against Cartesianism and metaphysics at least in a heuristic way.

It is after gaining a certain grasp on experience taken phenomenologically that the implications of the polemic begin to show the need for a second step, a second phenomenology. Thus through the approximations and a first movement, which is styled after the descriptive phenomenology of Husserl, I shall begin a second movement, which allows descriptive phenomenology to make its transition to the *existential*. It is *through* descriptive phenomenology that the existential dimension is first grasped in its significance. The existential is not a return to the “natural attitude,” although existential significations function as the ultimate “natural attitude” of phenomenology. The problem will be to show in the process how the more radical language of a Heideggerian-style second phenomenology is “natural” once its proper location is detected, for second phenomenology remains *descriptive*. This, however, must also be shown in the process itself.

The subject matter of this double inquiry is the whole range of auditory phenomena. This is to be a phenomenology of sound and listening. Beginning with an inquiry into the structures and shapes of sound, into existential possibilities of auditory experience, the investigation will range across a wide variety of human experiences in which sound and listening play crucial roles.

Clearly with humankind there is that focal speaking and listening activity of our babbling being, language in its auditory form. Closely related to spoken and heard language is the range of musical phenomena. There is also the noise and voice of the environment, of the surrounding life-world. There is the enigma, particularly for a first phenomenology of presence, of the horizon of silence. In more existential terms, the voices of language, of instruments, of the earth implicate things, persons, and the gods. For listening is listening to ———. And pervading the whole of the auditory dimension is the question of the inner voice as well. Each of these items must be queried in such a phenomenology.

This page intentionally left blank.

Chapter 3

First Phenomenology

First phenomenology begins under the sign of Husserl. It is a beginning that strives to move us from where we are in terms of common assumptions and implicit beliefs to a different plane of understanding in the phenomenological attitude. To do this, a philosophy in the *style* of Husserl employs a double level of meanings. The first level of a Husserlian styled philosophy may be termed “literal”; and at this level of meaning phenomenology may be understood as *a philosophy of experience*, but a philosophy constructed along the lines of most previous philosophies.

Thus the phenomenological “metaphysics” is one that is based on what has been often called *a radical empiricism*. At this first level, phenomenology, sometimes characterized by Husserl as the creation of a genuine and *pure* descriptive psychology,¹ is a science of the mind in contrast to the sciences of physical extension in the Cartesian paradigm. The aim is to isolate, describe, and discern the structures of immediacy or of fulfillable *experiential presence*. It is this aim that in retrospect can be seen to determine the theory of evidence that emerges in and from the phenomenological investigation itself. Primary evidence, “primordial dator evidence,” as Husserl termed it, is anything that can actually be noted within experiential presence in the way in which it gives itself out. It is around this primary evidence that all other evidences must be scaled, judged, and arranged. In this, first phenomenology is *a philosophy of presence*.

Again, in the first and literal reading of Husserlian-style phenomenology, this primary evidence is considered as that which is “given,” although the “givenness” may not be what is only superficially present at a first glance. The task of isolating the appearance of experience as a phenomenon is actually an imposing one.

Second, in its first form, phenomenology is basically a statics of experiential presence. It seeks to uncover, once the field of primary evidence is isolated, the structures, invariants, and essential possibilities of that field. And while it turns out that not all essences will be clear and distinct (some will turn out to be “inexact,” or, in Wittgensteinian terms, will have “blurred edges”), the aim of the first form of phenomenology is to make as precise as possible the shape of the experience being investigated.

In both these moves, first phenomenology as a *radical* type of “empiricism” remains roughly within the framework of traditional metaphysics, at least so long as the reading is literal. Primary evidence, fulfillable experiential immediacy, forms the foundation or ground-stratum as a given from which all other evidences derive or to which they relate back. Thus one might say that the distinctiveness of this “empiricism” is that it makes *experiential immediacy* the ground-stratum or primary substance of its metaphysics (rather than mind, matter, or something else).

Of course phenomenological “empiricism” also differs from classical empiricism from the outset, for it turns out that its field of experience is ultimately *total*. Its radicalism lies in the way this totality is taken. For example, in perceptual phenomena as one (privileged) *region* of experience, there is no distinction between primary and secondary qualities. All qualities are from the first “horizontalized” and must be taken as they give themselves out. And what is discovered is that what is given *in* perceptual experience is not at all a set of discrete qualities, but *things*, precisely those rich things that “blended” and “unified” the Lockean qualities that Locke overlooked as primary.

But concepts also give themselves out within experience. “Red” or “white,” however, must be investigated *in the way* in which they are given. One can experience a concept, for example, in using it in a proposition, without seeing red at all; but that type of experiential presence is quite distinct from the “bodily presence” of a “red” thing as a perceived thing. Moreover, the task of discerning the relations between the experience *of a* concept and its relation to the embodied thing experienced perceptually is also a problem for phenomenology.

It is here that the discrimination of “distances” arises. For once the types of evidence are sorted out, the next task becomes one of arranging and relating all matters by their relations to the primary fields of “givenness.” This is a matter of philosophical measuring or situating of regions

of phenomena.² With this consideration a third relation to empiricism may be seen, for despite a radically different way of interpreting perception, first phenomenology with both Husserl and Merleau-Ponty is at least implicitly perceptualist. The focus of primary evidence is *perception*. Thus, one set of distinctions internal to phenomenology arises over the distance and difference between fulfillable perceptual immediacy and any “higher” level and more distant “constructions” in other modes of thought. There is a weighted beginning in the concreteness of perceptual experience.

All of these complex considerations meet in a rather oversimple illustration. Consider a problem having to do with a language puzzle about color. In the mid-twentieth century it is quite often the case that if a professor asks her class, is black a color? she will be likely to receive a number of negative answers. As reasons for their answers the students will recite what they have learned concerning color from the sciences, perhaps claiming that “real” color is defined in terms of wavelengths of light. But if the professor’s question is, What color is that? while pointing to the blackboard, the overwhelming answer will be, simply, black. What, then, is “black” “really”? Here the answers soon may become enmeshed in metaphysical commitments and arguments.

The phenomenologist, however, approaches this problem somewhat differently once the reductions have been put into play. His task is to locate the *difference* and the type of *distance* between these two meanings of color, or, to use his terminology, he seeks to know how these meanings are *constituted*. That there is a rather large difference of context is quite clear, but contexts, the phenomenologist claims, must always have some weighted focus to make the discernment of distance possible. For first phenomenology that weightedness is *presence* or experiential immediacy. Thus, only the second case yields the *experiential* context for black *as* a color. Neither is it a mere color. A more profound analysis would reveal that constellated with the meaning “black” taken perceptually there are “values,” “symbolic significances,” and “feelings.” In the other “physical” context the experience of color *as* color is irrelevant: in its purest sense there is *no* color as color experience, but a reading of an instrument. In the phenomenologist’s terms, “physical” color is quite distinct from “perceptual” color.

That is because these two meanings are constituted differently. “Physical” color is “experienced” *through* a machine, it is “read” hermeneutically. “Physical” color is thus constituted by a certain instrumental context or use while “ordinary” or “perceptual” color is constituted by the immediate perceptual context. But what is important in this first illustration is that phenomenology seeks to note and clarify the distance and difference of these two sets of related phenomena in terms of the key value given to

perception as the weight that allows all other values to be “measured” from it. In this, phenomenology does not appear to be vastly distinct from some contemporary analytic philosophies, except that phenomenology takes as its primary evidence the region of fulfillable experiential immediacy as a starting point.

However, the student first entering phenomenological studies must be wary, precisely because the first literal reading of Husserlian philosophy is in fact only a preliminary approximation to phenomenology in its full sense. This is already discernible to the careful reader of Husserl. Not only does he use familiar, or “empiricistic” language deliberately to *lend a* certain initial clarity to the enterprise (because clarity is closely related to familiarity), but he makes one aware that he is employing this familiarity heuristically by his use of quotation marks and metaphors. Ultimately a second, nonliteral or hermeneutic reading of phenomenology is necessary if the outline of genuine phenomenology is to be reached. For although phenomenology may begin by an apparent “pure psychology,” Husserl maintained over and over again that this “pure psychology” was ultimately the way to *transcendental philosophy*. And once this step is taken one can see retrospectively that in its depth phenomenology is not a metaphysics at all, or even an “empiricism,” for its destiny is that of an existential-hermeneutic philosophy that arises out of a descriptive ontology.

This movement from a “literal” to a hermeneutic reading of first phenomenology comes while it is underway. And the entry to the venture arises with the construction of the Husserlian “machinery” that in this context has been simplified and stylized. The doorway to phenomenology is *epoché* and the doctrine of the *phenomenological reductions*.³

To shorten and simplify matters one may regard the various reductions as hermeneutic or operational “rules” under which phenomenology operates. *Epoché* is the initial and general term for the phenomenological reduction overall. In Husserlian terminology *epoché* includes “bracketing,” the “psychological reduction,” or “phenomenological reduction.”

The term *epoché* in its broadest sense means “to suspend” or “to put out of play.” But *what is* suspended is to be a certain set of taken-for-granted beliefs. It is a suspension of “presuppositions” rather than a reduction of (primary) experience. But, understood here as a hermeneutic rule, *epoché* is an exclusionary and selective process. It is a rule that *excludes*, “brackets,” “puts out of play,” all factors that may not be noted as “bodily present” or actually fulfillable (intuitable) within ongoing experience.

This exclusionary rule is meant to place out of bounds certain ordinary and certain scientifically theoretical and even certain logical philosophical

considerations. Thus, for example, in the descriptions of experience that are to follow, *epoché* as a rule excludes any physiological, physical “explanations” from the description itself. Also, all those assumptions of ordinary explanation must be put out of play, because ordinary experience already contains the sediments of “metaphysics.” Furthermore, argument that infers or draws on some mediate line of reasoning is suspended in the interests of isolating and allowing the phenomenon to “appear” in its fulfillable or intuitable presence.

This exclusionary aspect of the rule is matched by its positive selectivity, which sets apart for investigation the chosen field of experiential immediacy. It is to this field that phenomenology first turns. *Epoché establishes the “phenomenological attitude” or the perspective from which experience is to be taken.*

In this simple way this is quite easy to call for, although in actual practice the use of *epoché* turns out to be exceedingly difficult. But in its very difficulty one learns about the aim of phenomenology. Extensive work and thoughtful effort are called for in establishing the purposeful and disciplined phenomenological “naïveté” that is the beginning of phenomenology.

The second hermeneutic rule applies to the field of fulfillable experience, the selected and isolated field of investigation. It must be strictly correlated with the first rule: *Describe the appearances or phenomena.* In this case description calls for a careful note taking of what goes on in the “flow of experience.” Moreover, the descriptions undertaken presuppose the “purification” called for in the first rule: Describe, don’t explain.

In Husserl’s own works there are constellated around this second rule a series of other subrules. For example, in *order* of concern, once a field for investigation has been selected, one begins with the “objects,” or things which are “out there.” These were called the *noema*, or “object-correlates,” of the experience process.

But as these terms will be better introduced later, the way of description may begin partially here. At first a field of investigation will appear to be confusing, precisely because there are too many features to be noted. But what is of interest in the investigation is the *eidetic* or structural components of the experience in question. Yet these “patterns” are not immediately apparent. In this, again, phenomenological “psychology” is like any new science. It must look again and again at the phenomenon before it reveals its secrets.

There are two ways in which structures or invariants may begin to appear. The first may be called cataloging, which is the crude taking account of what goes on by listing what shows itself in a given moment of the “flow of experience.” It soon becomes apparent that this list will be immense. But it does serve to demonstrate the complexity of the phenomenological field.

It also serves to broaden phenomenological attention that begins to take note of much that is merely implicit in ordinary experience.

Equally or even more effective in discerning structures is the “gestalt” occurrence. It may and often does occur that a single experience will show an essential structural feature. For example, if I suddenly snap my fingers to the side of someone who is sitting with eyes closed, the *essential* directionality of experienced snapping sounds is presented.

Both of these devices fall within the use of what Husserl termed the use of *variations*. Fantasy or imaginative but also *perceptual* variations are the main methods for detecting essences. In Husserl’s case these variations were largely modeled on the notion of imaginative variations in the logical and mathematical *essential* sciences. But for reasons that again will become clearer later, Merleau-Ponty preferred the use of actual *perceptual* variations, not only because he was more explicitly “perceptualist” than Husserl, but because often the wildest imaginations do not yield many of the possibilities of the perceptual world.

Beginning under the sign of Husserl the preference for the essentially possible over the factual must also be noted. Logic and mathematics are sciences in which the essential or possible takes precedence over the factual. Husserl’s belief was that such sciences are in a sense “regional,” that is, they do not exhaust the full range of possibilities. Husserl’s hope was that phenomenology would create the ultimate essential science as the analysis of all of the various “regions” of possibilities. This was descriptive psychology become philosophy.

What is to be of special interest here is the notion of a particular type of essential possibility, one that relates to the dimension of auditory experience. Because of its limitation to a dimension of experience I shall term this region of possibility a region of *existential possibilities*. But because there is also a need for a preliminary and at first schematic outline of existential possibilities, it may be necessary to differentiate them from the more familiar “logical possibilities” of contemporary philosophy. Existential possibilities form a particular type of possibility in the investigation of an actual dimension of human experience. In particular the various uses and roles of imagination in the development of both logical and existential possibilities call for initial attention.

There is a sense in which it can be said, again particularly in relation to certain types of imagination, that philosophy has always used fantasy as its tool. On the contemporary scene, particularly since Husserl’s day in the analytic philosophies, a sophistication of one type of imaginative variation has flowered, that of the logical possibility. But precisely because this type

of possibility is now familiar, the potential for a serious confusion concerning the Husserlian wider use of imaginative variations arises. For Husserl and for all phenomenology, logical possibilities are but one dimension of possibility, in this they are “regional” in a certain sense.

Such a claim might at first seem outrageous; yet Husserl himself often enough made it by noting that logic must itself be one of the sciences which is to come under *epoché*.⁴ But the purpose here is not to enter into an argument concerning that development and its implications. It is rather to open the way to a contrast of logical and existential possibilities such that a different type of variation that becomes greatly important in phenomenological “psychology” can emerge. But as it is understood within phenomenology, the existential is not a matter of mere “contingency.” Yet that is the understanding which invariably arises from the logistic prejudices of the still positivistically inclined thinker familiar with “logical possibilities.” “Contingent” possibilities must fall under the domain of psychology. Be that as it may, the existential possibility to be discussed in what follows has as its central demand that it be a phenomenon that can be fulfilled by an intentional aim, a phenomenon that is *experientially possible*.

It may be that the experientially possible is a “narrower” region than that of the logically possible, although until investigation it is also possible that the reverse is true. But in any case the first demand for the location of an existential possibility is that it be fulfillable in experience.

Not all (emptily) imaginable possibilities are in fact fulfillable. There is a whole range of presumably easily “imagined” possibilities that are deceptive in appearing to be “clear and distinct” when, on closer examination, they turn out to be confused and incomplete. Thus in the isolation and description of an existential possibility it is necessary that it be checked as fulfillable. In this, looking for existential possibilities is like an empirical procedure in that each item is to be checked and verified in principle in actual experience.

In all the examples that follow, particularly in those I have chosen to put forth stylistically as the autobiographical “I can ——,” the experiences have actually occurred. There is a sense in which phenomenology begins with the first person, *I*.⁵ But such is not the last word. In *every* case the use of the stylistic “I can ——” in this book has been checked against the experiences of others. There is also the possibility of an intersubjective cross-checking, correcting, and expanding of discovery of essential possibilities in phenomenology.

That an existential possibility be actually intuitable in experience is a necessary but not sufficient condition of its location. A second aspect of

the description of such possibilities is that one must note carefully *how* and *in what way* the particular variation occurs. For example, is this an ordinary or an extraordinary phenomenon? Does it occur centrally or peripherally? Can it be pushed further? And so forth. This is the way that the quite different uses of variations as plays of fantasy and as other types of variations begin to be clarified. “Logical possibilities” call for a certain “abstractive” and “reductive” use of imagination. But existential possibilities ever more closely approach the concreteness—of what is essentially human. Thus whereas I can emptily “imagine” or conceive of a “world” of sound as a “No-Space” world in Strawson’s sense,⁶ when I turn to all the variations of my fulfillable experience of listening I find this is essentially *false*. For such a “No-Space” experience to be actualized I should have to be disembodied—but then would there be any “hearing” at all? (Ultimately, were this the point at issue I should argue that it is essentially *impossible* to fulfill even the imagination of a “No-Space” world. Such a world is, in Husserl’s term, an “empty intention”—but so is a square circle an “empty intention.” What is being confused in such an “empty” imagination is a region of thought that might be called *supposing*, but supposings are not necessarily fulfillable. They, too, need to be investigated as a region of experience, but a too-quick leap from an empty supposing to some kind of existential possibility leads to the confusions of analytic empiricism.)

From what has been said to this point one may gather that the procedure of locating and determining existential possibilities is not argumentative in the usual philosophical sense. There is not to be found here an argument in the sense of a deduction or one in the form of hypothetical-deductive reasoning. There is rather a gathering of descriptive characteristics in relation to the region of experience being investigated. However, I should say by way of anticipation that such a gathering, particularly in its mosaic accumulation, plays within phenomenology a role which *functions like* an argument. The detection and descriptive analysis of some feature of experience may be thought of as an *intuitional demonstration*. I first perform the act which is called for and find or do not find the case to be such and such. In turn, I may call for another to perform the same operation in cross-checking the result.

There is, in this process, even the possibility of correction. The other may have noted something which I either did not detect fully or which I did not think so important and thus left out. However, like an argument, the condition for the possibility of cross-checking depends rather thoroughly on both investigators holding to the same framework or perspective from which the demonstration may be sought. In an argument if both sides do

not hold to, say, the law of the excluded middle, a vast confusion is likely to result. So, also in phenomenology, an intuitional demonstration depends, for accurate results, on a certain awareness of the “rules” of the procedure.

Fortunately, in a very general sense, the phenomenologist can rely on a certain latent “phenomenological” ability on the part of others just as the logician can depend, in a very general sense, on a latent ability on the part of others to learn what is necessary to conduct a correct argument. Thus I can rely preliminarily on the other to have such and such experience and on the other to be able to detect whether such and such may or may not be the case. But it remains important that all variations be checked and cross-checked and not taken in their first and most superficial sense.

Another example of possible different directions for the use and type of imaginative variation may be illustrated by the “habitual” differences between a philosopher’s way of “seeing” things and that of an artist. For instance, a long and ancient tradition in philosophy involves the use of an abstractive imagination in the constitution of logical “essences” or universals such as *predicates*. Although there have been centuries of argument about the status of such entities, one illustration revolves around two different types of possibilities of perceptual experience.

If I place before myself a “white” duck, a “white” chair, and a “white-haired” old lady and assume the usual context of the philosopher’s way of “seeing” the world, I will probably structure the situation by asking what is *common* to these three “objects,” and probably I will quickly come up with “whiteness” or some such conclusion. Yet, in a critical examination it is not at all clear or “obvious” that there is this commonality as perceived, for were I an artist I might well note that the “white” of the duck is a soft, feathery white in its concreteness; the white of the chair is glossy, hard; and the string gray with white of the old lady’s hair all strike me as “vastly different.” Does the philosopher “overlook” the concreteness of the various whites? Or does the artist not attend to abstract universals? Yet the artist also has his own “essential” insight into the various whites as he makes them “shine forth” in his painting. Phenomenologically, the philosopher and the artist experience or focus their experiences in quite different ways in relation to the phenomena; yet also phenomenologically under the stipulations of *epoché* both are “equal,” and there is a matter of too much rather than too little “truth.” The problem is one of discerning different types of essential possibilities.

There is a sense in which Wittgenstein in particular was sensitive to such nuances of differences in a very “phenomenological” way. The notion of family resemblances, already noted as a counterpart to the Husserlian notion of some types of inexact essences, is an attempt to recognize the

noncommon relatedness of many phenomena in the mesh of ordinary language that does not display simply some clear “logical” structure.

But the point here is not to trace the history of the polymorphy of conceptuality. It is to caution about confusing two directions of the use of fantasy variations in which constructed examples, often employed early in what follows, become increasingly suspect if the sense of the existential possibility is to be elicited.

To begin with, then, any fulfillable possibility of the dimension of experience being investigated may be considered an existential possibility of that dimension of experience. And in relation to a given dimension of experience there may be innumerable such possibilities. But these gradually reveal a shape. As existential possibilities are discovered, a map of the terrain of experience may begin to appear in rough outline. Then two further steps may be noted. First, there is the need to fill in and precisely define the outline; and, second, there is a need to try to discern the limits of the region. It is in relation to limits in particular that a special problem arises.

There is a sense in which any fulfillable intention attains an “apodicity” or certainty. In Husserl, “apodicity” or certainty is the *weaker* category. What is stronger is *adequacy*, but there is often a serious uncertainty about what can constitute adequacy. When has one truly reached the limits of an existential possibility? That doubt must remain here as well as in the realm of logical possibilities. All essential sciences seem to display a certain openness or infinity of direction.

However, what can be done with beginning variations is a depiction of a “mosaic” map or survey of the terrain into which the investigator enters. The sampling of some existential possibilities gradually builds up an outline. As gestalt psychologists know, a “mosaic” of dots is often sufficient to display the picture. I do not claim to have in any way exhausted or even to have reached totally adequate limits of a phenomenology of sound and listening in the descriptive section. But I would hold that the existential possibilities elicited are suggestive of a need for philosophy to examine human experience more deeply than it often has.

In this simplified way first phenomenology remains within what at first may be called a “pure” or “descriptive” psychology. *Epoché* that outlines the field and the descriptive demand with its tool of variations for the noting of essential possibilities form the first steps of a Husserlian-style phenomenology.

The third step of the reductions, Husserl’s “transcendental reduction,” is what makes a phenomenological psychology philosophical. It allows the field of experience to become universal under the notion of *intentionality*. How-

ever, again for the sake of simplicity, the “transcendental reduction” may also be regarded as a hermeneutic rule, this time described as a correlation rule.

First phenomenology contends that once underway *all* experience, whether fulfilled or remaining “empty,” is found to have a specific shape in that all experience is “referential,” “directional,” and “attentional.” All experience is *experience of* ———. Anything can fill in the blank. The name for this shape of experience is intentionality.

But as a hermeneutic rule of correlation, intentionality may be seen to *function* in phenomenology by giving a shape to phenomenology itself, a “model” or paradigm for its understanding. There were different ways in which Husserl characterized this structure of experience. It was the ego-cogito-cogitatum, the self-experiencing something. In later phenomenology this notion was purged of its Cartesian overtones and made into Being-in-the-World. It was also, with Husserl, the structure which, within itself, could be differentiated according to the sides of a relation. But throughout it is the *relationality* of intentionality which must be maintained if phenomenology is to remain phenomenology proper.

In the period of the *Ideas* the distinctions that later were modified in various ways set the pattern for intentionality. Within experience overall there is that which is experienced, that called the *object-correlate* or *noematic* correlate. And, in strict correlation with the *noema*, there is the act of experience or the experiencing that was the “subject-correlate” or the *noetic* act.⁷ Here, as a correlative rule, it is maintained by intentionality simply that for every object *of* experience there is an act or “consciousness” that apprehends that object, and for every act there is an “intended” correlate, although some may not be fulfilled (empty).

This correlation as the phenomenological “model” gives phenomenology its characteristic shape. Anything outside the correlation lies suspended under the previous terms of *epoché*. Thus any object-in-itself and equally any subject-in-itself remains “outside” phenomenology. It is here that the Husserlian avoidance of “realism” and “idealism”—both of which are ultimately inverse sides of the same “metaphysics”—arises. “Objectivism” and “subjectivism” are both part of a “Cartesian,” dualistic myth to which Husserlian phenomenology sees itself opposed as the radical alternative.

To interpret this correlation rule into its simplest terms, I shall employ a modification of the later terminology of “Being-in-the-World” which may, be illustrated as follows:

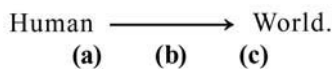

In this diagrammatic scheme for the phenomenological correlation, (b) stands for the constant rule of relation between (a), the human experienter, and (c), the experienced environment. The correlation (b) symbolizes intentionality as first directional (the direction of the arrow) *toward* the world (c), which may be taken either as an “object” or as the totality of a “surrounding” world. In its strictest sense although (c), as the noematic correlate may be described “first” and in a sense comes “first” in experience, it is never separate from its being experienced (a) in retroreference to the experienter. The opposite is also true. Furthermore, the modality and type of experiential relation (b) is from the beginning variable and complex in that it includes all possible experience rather than just cognitive or judgmental experience.

In the first instance the human of the correlation is always “me.” I am the first instance of the correlation. However, one important modification must be introduced from the outset to avoid the problem of a “transcendental illusion.” Although the diagram simplifies, it also confuses, because it tempts one to view it “from the outside” or “from above.” I who am “in” the equation am suddenly also “outside it” as a “transcendental ego.”

Most post-Husserlian phenomenologists have rejected this interpretation, and if carefully understood the diagram has an interpretation which calls for no outside “transcendental ego.” That interpretation is one which calls for a complementary aspect to the correlation of Human—World. If the “outward”-facing arrow of the intentional relation symbolizes my primitive involvements with the surrounding world, I also find that I may *reflect* on that involvement by way of a modification of experience. Yet this reflectivity is implicit in every experience as well. It may be symbolized by an “echo” arrow:

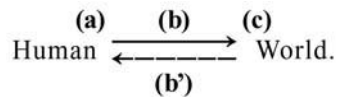

By this if (a), the subject, is related primitively in (b), intense involvement, with (c), the surrounding world, (b') is the reflective “stepping back” or “distancing” that I may make *within* the larger context of involvements. Reflection (b') is a special mode of (b) as self-awareness of the primary experience. The implication—again quite properly “anti-Cartesian” in the phenomenological radical alternative—is that I do *not* “know myself” directly in Cartesian fashion. What I know of myself is “indirect” as a reflection *from* the world. This also applies to others: I know myself as

reflected from others. What is primitive is the “immersion” in the world, as Merleau-Ponty puts it.

Reflection is, in a sense, an *experience of experience*, but even here it can be seen that as a reflective experience it retains the essential shape of intentionality as experience *of—and* implies that my own self-knowledge remains essentially *hidden*. To truly “know himself” in phenomenology one must “know the world.” Reflective knowledge is, in spite of the present necessary linguistic conventions, quite distinct from a “Cartesian” introspective procedure.

With this highly schematized and minimal set of methodological notions it becomes possible to gradually take an investigative stance. In so doing it is possible to begin to take note of some features of perceptual experience and simultaneously to introduce secondary notions while under way. I have deliberately chosen to begin with visual experience and, further, to deliberately fashion some of the subsequent explications of intentionality on a visualist paradigm. In the following description, the concern is with noting preliminary features of perceptual intentionality.

I sit at my desk composing this chapter. I pause to reflect on the ongoing experiences just previously lived through, or even currently going on. I am perhaps first overwhelmed by the complexity and polymorphous character of that experience. Were I now to begin to catalog, item by item, even what I might recall in the few moments just past, and were I to do this thoroughly, it is conceivable that a rather large list would result.

However, I decide to deliberately focus my attention on one dimension of that ongoing experience, its visual dimension. I begin to take stock of what I see and how I see within the moment. I note that while composing I focus on the words taking shape under the keys of the typewriter: I note the errors, the stylistic and grammatical oddities, curse the wrong letters. I focus my attention even more narrowly and note that it is fixed roughly to a certain area on the paper. At this stage I may describe this as a certain area of relative “clarity” that “stands out” and gradually “shades off” into an area of relatively less clarity or even farther out to a certain “fuzziness.” Noematically within my visual field there is a “center” of the clearly and distinctly perceived that shades off into a “periphery” or “fringe” of the indistinctly perceived.

Also, strictly copresent with this seeing in which I am involved there is what I recognize, however implicitly, as the “mineness” of the experience. My seeing, my attending, my focusing, or equally put, the phenomena that “stand out” refer back to “me.”

I further note at this preliminary stage that there is a play of inversions which goes on in the “flow” of experience. When I am attending to the

paper there is a “ratio” of what is clear to what is fuzzy that runs from center to periphery. And if I turn my eyes upward to note something typed farther up the page, what has just been seen as clear now becomes less so, but the ratio between the central and relatively clear focal area and the peripheral and relatively fuzzy peripheral area remains constant.

Here are, despite their familiarity in gestalt psychology and even in much common parlance concerning the visual field, the beginning outlines of a “structure” within visual experience, which is for phenomenology an intentional structure. The noematic *core* or area of *focus* of the visual “world” is preliminarily distinguishable from its noematic *fringe*. Correlatively, the act of attention is a focusing (noetic act) that as an experiential structure displays a central awareness that shades off into the barely aware or implicit consciousness at the “fringe” of more explicit or focused attending.

I return to my visual experience. I now note that ordinarily I am concerned with, focus my attention on, things or “objects,” the words on the page. But I now note that these are *always* situated within what begins to appear to me as a widening field that ordinarily is a *background* from which the “object” or thing stands out. I now find by a purposeful act of attention that I may turn to the field *as* field, and in the case of vision I soon also discern that the field has a kind of boundary or limit, a *horizon*. *This* horizon always tends to “escape” me as I try to get at it; it “withdraws” always on the extreme fringe of the visual field. It retains a certain *essentially* enigmatic character. But within the field, as I return to the ordinary attending and my involvements with things, I discover that not only is the “world” of vision referred to me within experience overall, but that all the “objects” within that field of visual experience are *never* unsituated even within the field. Things or “objects” appear *only* as *essentially* situated *in* a field.

Within this preliminary glimpse certain “essential” structures or existential possibilities of visual experience are already anticipated. However, the purpose of this preliminary survey, which latently includes many phenomenological results, is to begin to model what in various modifications underlies the phenomenological notion of experiential intentionality. The illustration noted above can be diagrammed as shown (fig. 3.1).

Noematically the appearances of the visual “world” in most ordinary experience display (i), a *focal core*, that which stands out before on e, the central “object” or object range of the visual intentionality; (ii), the peripheral fringe, situated in relation to the core but never absent even if not explicitly noted; (ii) shades off to (iii), the *horizon*, which is the “border” or limit of the visual field and its “beyond.”

Together (i), focus, and (ii), fringe, make up the totality of the visual field, the totality of explicit to implicit visual *presence*. The horizon (iii) is

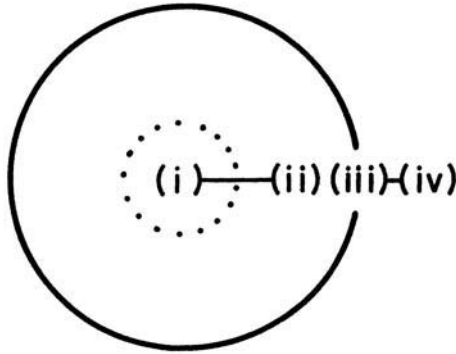

FIGURE 3.1 Core-Horizon Structure

sensed as a limit to the “opening,” which is the visual field, and this sense of limit is the first sense of horizon. But beyond the “edge” of the visual field *nothing* is given as present, the “beyond” of the horizon is an *absence*, or emptiness (iv). Thus horizon has two meanings from the outset.⁸

Within the purposeful naïveté of the phenomenological reduction this first step is one of attending to that which is experienced and to the “how” that which is experienced is presented. However, strictly copresent with the appearance is the *reflective awareness* of this experience as “my” experience. It is “I” who does the focusing; it is to “me” that the fringe appears as background, as the not-specifically-attended-to; and it is “I” who detects the strange boundedness and finitude of the visual field that raises the question of the World that lies “beyond” the finitude of “my” opening to the World.

Progressing now within this simplified framework, I return to my visual experience. I note that in ordinary experience there are certain patterns and resistances to the way in which these structures function. For example, no matter how hard I try, I cannot extend my horizon as limit. It remains at the “edge” of the visual field, and as I turn my head it “turns,” too, but in such a way that it remains an absolute if vague “edge” while what is central also remains *before me*.

I also notice that ordinarily there remains a discernible *ratio* of the explicit to the implicit in relation to my attending acts. By exercising a series of variations I begin to find that there are, however, certain variable qualities to this ratio. The ratio of core-to-fringe may be exceedingly “narrow” in a “fine focus” of a visual act. I look at the tip of my pencil, taking in its grain, texture, leaden quality. But as I observe in a narrowly and finely focused mode the fringe “comes in,” and that which is implicit and vaguely present, while still situating and surrounding the core, presents itself as covering most of the visual field.

But I can also “expand” the focus more “widely” and take in within central vision those faces before me in the classroom. Here the core area of clarity has expanded, and the fringe recedes farther toward the horizon. However, this variability seems to be limited in ordinary experience to a relatively variable ratio of central to peripheral core and fringe.

I push the variations more extremely and wonder if this ratio can be even further expanded. Can it, for example, become so “broad” that it stretches to the horizon? I reflect on my experience and discover that there are exceptional instances that approximate even this possibility, but they are not “ordinary” in the sense of belonging to the usual daily activities of ongoing involvement with the environment.

I recall lying on my back in a sunny field in a state of youthful boredom. The world appeared to me as “flat,” “all the same”; it presented itself as “indifferent.” Phenomenologically, I was attending to nothing-in-particular, and the focal core itself receded toward a limit of disappearance in the *blank stare* of boredom. I shall call this a *field state*. Another variation in contrast to this is the state of ecstasy such as a first experience of a natural wonder. I remember the first time I came on the Grand Canyon. It was at dusk when the whole panorama stretched before me with its blue and purple hazes, and in a brief moment of speechlessness *everything* seemed to be transformed. Again, while the ratio of core to fringe did not entirely disappear, here the focal core “expanded” with intensity toward the very horizons of the visual field as a panoramic whole.

Both the blank stare and the ecstatic vision reveal something of the heightened or depressed appearances of the phenomenon of the world. For in phenomenology *every mood* reveals something about the quality of an appearance. In the state of boredom the visual “world” lacks its normal sense of involvement “with me,” whereas in the state of ecstasy the “whole world” leaps out “toward me” in its beauty and awesomeness. Only the viewer who has refused to recognize this and has subtly assumed or presupposed that a “neutral” state of observation is “normal” views such differences “abstractly” and fools himself into believing that the visual qualities of this range of experiences are the “same.” But this is not to descriptively analyze visual experience; this is to transform it into an “abstract” seeing. Nor is it accidental that the preference for a “neutral” or “abstract” state is preferred as a *standard* of vision by the “Cartesian.”

This first survey of one dimension of experience is intended to illustrate paradigmatically some of the ways in which a phenomenological “psychology” operates. In terms of the initial Human-World correlation model the relational arrows are *constant*. They are not lifted. But *within* the constancy there may be seen to be a variable and “floating” movement of

weighted focus. Not only may we shift our intentional involvement toward the “objects” or noema at the World side of the relation and then shift back reflectively to the act-quality of the intention, but the full implications of the “flux” of the quality of the type of involvement may shift. In the field state of boredom the quality of the relation is quite different from that of an ordinary state of involvements, and likewise in an ecstatic state the quality of the relation is different again. In this sense every “mood” has epistemological significance for the phenomenologist.

But, at a higher level of consideration, the constancy of the relation of human being *in* the World is what bespeaks the phenomenological sense of one’s being “immersed” in the “surrounding world,” and at the same time within that sense of the world of human being, as Merleau-Ponty put it, the human is “already outside himself in the world.”⁹ Within the correlation of phenomenological experience overall it is a relation with the world that is known.

If this is so, there remains the implication that all forms of world-knowledge within phenomenology are relational; but likewise, all forms of self-knowledge are also relational. At one level there may often be found a kind of symmetry between world-knowledge and self-knowledge that is symptomatic. For example, in historical and cultural myths there is often a typological similarity between what is taken as a primary world reality and human-reality. Thus in archaic cultures the hunted bear or other totem of the tribe was also a brother who was considered to have a spirit not unlike that of humans. The quality of the surrounding world of the so-called animistic societies reflected back on the human self-understanding in relation to that environment. If contemporary man thinks of this symmetry as merely a “primitive anthropomorphism,” then the question might equally be raised about a similar symmetry in the contemporary world. A technological culture increasingly seems to view the world not only in “mechanistic” terms but humankind as “like” a machine, even if the latest variant is that of a highly complex and programmed computer. Here the anthropomorphism functions as strongly as ever, only the model of the relational other is changed (computer for animal).

A simple parable of learning of the self *through* or reflected in the world can be hypothesized in terms of an imaginative self-learning concerning the eye.

Imagine an odd and restricted case of a visual “world” with but one viewer. Here there are no mirrors and no others, those more ordinary “reflectors” by which we learn of ourselves; yet the viewer “sees” this “world.” He takes note of just those features outlined in this initial model of a “visual” intentionality and, through reflection, asks what must be the nature of his

strange “opening” to the “world.” He notes that the visual field is bounded by the roundish horizon. Is his “opening” also roundish? He notes his ability to focus and to vary the focus on the face of the “world.” Does he have a “variable” opening, and so forth? Of course this need not be the way we actually learn of ourselves and the way in which the pupil of the eye functions. Ultimately the example hides more than it reveals, because without others and language it remains even doubtful that there could be a full self-reflectivity at all (a reduction of the world implies a reduction of the self!).

In the actual world, others and mirrors reflect us to ourselves, but the principle is still the same in that it is only by being “outside myself in the world” that I gain the reflective self-knowledge that I have. Moreover the “first” experience with a “mirror” is often quite curious and causes a sense of wonder. Jane Goodall’s wild chimpanzees were amazed and often would quickly walk around the mirror that she placed before them to see who was “in” or behind it. And although visual mirrors are introduced too early for most of us to recall our wondering reaction to them, our surprised reaction to our voices reflected by the auditory “mirror” of the tape recorder is striking.

With this first visualist approximation of a model of phenomenology, now with perceptual experience in mind the first extension of the model may be the *auditory turn*. In what ways does or doesn’t the model apply to the auditory dimension? The claim of a Husserlian phenomenology is that directed intentionality with its range of possibilities is an essential or invariant structure of experience.

However, with the question of an auditory turn there also arise serious preliminary questions that must be considered. What is involved with the examination of a “region” or dimension of experience? Here stands a crossroads at which phenomenology may make its own way or become confused by highly sedimented and accepted traditions concerning experience.

What is involved in a “reduction” *to* listening? Or is a “reduction” to listening even possible? The question may seem strange, exactly because we are accustomed by old habits of supposing and philosophical thought to seemingly do just that. What is more obvious than the five senses? This is precisely the danger point where the very first step of *epoché* could founder.

If there is anything to be drawn from previous work in phenomenology, particularly from work concerned with perception, the first result should be to understand that the primordial sense of experience *is global*. For Husserl this emphasis comes across repeatedly in his insistence that it is the same thing that presents itself in various profiles and in the various modes of experience. For Merleau-Ponty and for Heidegger the primordial experiences of being embodied or incarnate in a world are, if anything, even more strongly dependent on the global character of primordial expe-

rience. In its ongoing and normal sense, experience in its first naïveté is not experienced as being constructed from parts. And as Merleau-Ponty has so clearly shown, even at the theoretical level a theory of perception is already a theory of the body and vice versa.¹⁰ In an existential phenomenology it is the body-as-experiencing, the embodied being, who is the noetic correlate of the world of things and others.

Yet the ease with which we assume a “reduction” to a sense remains as an easily taken-for-granted possibility that is sedimented in an old and particularly empiricist tradition. We “believe” that we can isolate one sense from the others; we “believe” that we “build up” or “synthesize” an object out of “sense data” or some other form of “sensory atom.” These “beliefs” lie deeply imbedded in recent times with the “sense atomism” that infects even the sciences at their “metaphysical” level.

But a phenomenological “empiricism” inverts this understanding. Its own scrutiny of experiential phenomena shows as foundational that at the first level the “synthesis” is what appears. Even a rather superficial reflection on normal and ordinary ongoing experience would show that we have no conscious awareness of “processes” that gather data, and then “build up” an object before us: the object “primitively” stands before us in all its diversity and richness and unity.

The reason such processes cannot be found lies within the metaphysical model long regarded as obvious in classical empiricism and in the even older traditions of metaphysical explanation. Ultimately sense data and primary qualities and a whole family of related unexperienced causes are ghosts that lie behind experience rather than lie *in* primordial experience. As an alternative view, phenomenology places in brackets precisely these “beliefs.”

Thus the turn to a “pure” auditory experience becomes complicated with the rejection of a metaphysics of the five senses. But it is much easier to say that sensory atomism is placed out of play than to practice it, because *epoché* from the very first implies the double task of setting aside explanations and of isolating its selected region of description. Is there no sense in which the phenomenologist can speak about auditory experience “as such”? Surely the deaf person relates to the world in ways different from those of his neighbors with hearing, and the blind man relates to the world differently from his sighted peers. Does not the lack of a sense show something?

The answer must be a qualified “yes” but in terms dictated by the nature of the phenomenological inquiry. It must take its shape from its own methods and understandings. That the blind or deaf man experiences his problem with frustration, living as he must in a society of others who speak and who see would seem to indicate a sense of the “lack.” Yet even the

blind man experiences his perspective of the world as global, as a plenum.¹¹ We do not experience ultraviolet “light” as light, and we cannot concretely even imagine what such an experience is like except as an empty supposing or by an analogy, but we do not experience this as a “lack.” Were we suddenly to be plunged into a society of bees and there have to make our ways, we should then begin to appreciate quite dramatically this “lack” that lies beyond the threshold of our visual experience.

But the proximate way in which the auditory turn may be made lies at hand in the already exemplified distinctions of a ratio of focus-to-fringe and of the ratio of the explicit-to-the-implicit. *Within* global experience the model of a visualist intentionality applies in its own way. I can *focus* on my listening and thus make the auditory dimension stand out. But it does so only relatively. I cannot isolate it from its situation, its embedment, its “background” of global experience. In this sense a “pure” auditory experience in phenomenology is impossible, but, as a focal dimension of global experience, a concentrated concern with listening is possible. Auditory experience can be thematized relatively, in relation to its contextual appearance within global experience. But just as no “pure” auditory experience can be found, neither could a “pure” auditory “world” be constructed. Were it so constructed it would remain an abstract world.

As an exercise in focal attention, the auditory dimension from the outset begins to display itself as a pervasive characteristic of bodily experience. Phenomenologically I do not merely hear with my *ears*, *I hear* with my whole body.¹² My ears are at best the *focal* organs of hearing. This may be detected quite dramatically in listening to loud rock music. The bass notes reverberate in my stomach, and even my feet “hear” the sound of the auditory orgy.

The deaf person—and most writers indicate that *total* deafness does not occur, since some hearing is by bone conduction with even highly deaf persons—has lost the use of his *focal* organs. She “hears” essentially differently than the normal listener. What are for normal listeners the fringe aspects of hearing, the feeling of the body of sounds that amplify the richness of focal hearing with the ears, are for the deaf person the “focus” itself. She is like a person with a central cataract obscuring his vision, who perceives only the periphery of the visual field in terms of the proximate model described above. An approximation of this sense of “hearing” may be discerned in the following threshold phenomenon.

In Vermont while lying in bed at night my son often asked what the strange vibration of the earth was, until we noted that this vibration modulated into the clearly heard approach of a high-flying jet airplane some minutes after the first “felt” detection of its approach. Later we all recognized the transition of “felt” to “heard” sound that the jet displayed.

Sound permeates and penetrates my bodily being. It is implicated from the highest reaches of my intelligence that embodies itself in language to the most primitive needs of standing upright through the sense of balance that I indirectly know lies in the inner ear. Its bodily involvement comprises the range from soothing pleasure to the point of insanity in the continuum of possible sound in music and noise. Listening begins by being bodily global in its effects.

This page intentionally left blank.

Part II

Description

This page intentionally left blank.

Chapter 4

The Auditory Dimension

What is it to listen *phenomenologically*? It is more than an intense and concentrated attention to sound and listening, it is also to be aware in the process of the pervasiveness of certain “beliefs” that intrude into my attempt to listen “to the things themselves.” Thus the first listenings inevitably are not yet fully existentialized but occur in the midst of preliminary approximations.

Listening begins with the ordinary, by proximately working its way into what is as yet unheard. In the process the gradual deconstruction of those beliefs that must be surpassed occurs. We suppose that there are significant contrasts between sight and sound; thus in the very midst of the implicit sensory atomism held in common belief we approximate abstractly what the differences might be between the dimensions of sight and of sound.¹ We “pair” these two dimensions comparatively. First we engage in a hypothetical and abstract mapping that could occur for ordinary experience with its inherent beliefs.

Supposing now two “distinct” dimensions within experience that are to be “paired,” I attend to what is seen and heard to learn in what way these dimensions differ and compare, in what ways they diverge in their respective “shapes,” and in what ways they “overlap.”

I turn back, this time imaginatively, to my visual and auditory experience and practice a kind of free association on approximate visual and auditory possibilities, possibilities not yet intensely examined, which float in a kind of playful reverie.

Before me lies a box of paper clips. I fix them in the center of my vision. Their shape, shininess, and immobility are clear and distinct. But as soon as I pair their appearance with the question of an auditory aspect I note that they are also *mute*. I speculatively reflect on the history of philosophy with recollections of pages and pages devoted to the discussion of “material objects” with their various qualities and on the “world” of tables, desks, and chairs that inhabit so many philosophers’ attentions: *the realm of mute objects*. Are these then the implicit standard of a visualist metaphysics? For in relation to stable, mute objects present to the center of clear and distinct vision, the role of *predication* seems easy and most evident. The qualities adhere easily to these material objects.

A fly suddenly lands on the wall next to the desk where the paper clips lie and begins to crawl up that wall. My attention is distracted and I swat at him. He quickly, almost too quickly for the eye, escapes and flies to I know not where. Here is a moving, active being on the face of the visual “world.” With the moving, active appearance of the fly a second level or grouping of objects displays itself. This being, which is seen, is active and is characterized by motion. Movement belongs to the verb. *He walks, he flies, he escapes*. These are not quite correctly properties but activities. Who are the “metaphysicians” of the fly? I recall speculatively those traditions of “process” and movement that would question the dominance of the stable, mute object, and see in motion a picture of the world. The verb is affirmed over the predicate.

But the metaphysicians of muteness may reply by first noting that the moving being appears against the background of the immobile, that the fly is an appearance that is discontinuous, that motion is an occasional “addition” to the stratum of the immobile. The fly’s flight is etched against stability, and the arrow of Zeno, if it may speed its way at all, must do so against the ultimate foundation of the stable background. Even motion may be “reduced” to predication as time is atomized.

But what of sound? The mute object stands “beyond” the horizon of sound. Silence is the horizon of sound, yet the mute object is silently *present*. Silence seems revealed at first through a visual category. But with the fly and the introduction of motion there is the presentation of a buzzing, and Zeno’s arrow whizzes in spite of the paradox. Of both animate and inanimate beings, motion and sound, when paired, belong together. “Visually” sound “overlaps” with moving beings.

With sound a certain liveliness also makes its richer appearance. I walk into the Cathedral of Notre Dame in Paris for the first time. Its emptiness

and high arching dark interior are awesome, but it bespeaks a certain monumentality. It is a ghostly reminder of a civilization long past, its muted walls echoing only the shuffle of countless tourist feet. Later I return, and a high mass is being sung: suddenly the mute walls echo and reecho and the singing fills the cathedral. Its soul has momentarily returned, and the mute testimony of the past has once again returned to live in the moment of the ritual. Here the paired “regions” of sight and sound “synthesize” in dramatic richness.

But with the “overlapping” of sight and sound there remains the “excess” of sight over sound in the realm of the mute object. Is there a comparable area where listening “exceeds” seeing, an area beyond the “overlapping” just noted where sight may not enter, and which, like silence to sound, offers a clue to the horizon of vision?

I walk along a dark country path, barely able to make out the vague outlines of the way. Groping now, I am keenly aware of every sound. Suddenly I hear the screech of an owl, seemingly amplified by the darkness, and for a moment a shock traverses my body. But I cannot see the bird as it stalks its nocturnal prey. I become more aware of sound in the dark, and it makes its presence more dramatic when I cannot see.

But night is not the horizon of sight, nor Dionysius the limit of Apollo. I stand alone on a hilltop in the light of day, surveying the landscape below in a windstorm. I hear its howling and feel its chill but I cannot see its contorted writhing though it surrounds me with its invisible presence. No matter how hard I look, I cannot see the wind, *the invisible is the horizon of sight*. An inquiry into the auditory is also an inquiry into the invisible. Listening makes the invisible *present* in a way similar to the presence of the mute in vision.

What metaphysics belong to listening, to the invisible? Is it also that of Heraclitus, the first to raise a preference for vision, but who also says, “Listening not to me but to the Logos, it is wise to acknowledge that all things are one.”² Is such a philosophy possible beyond the realm of mute objects? Or can such a philosophy find a way to give voice even to muteness? The invisibility of the wind is indicative. What is the wind? It belongs, with motion, to the realm of verb. The wind is “seen” in its *effects*, less than a verb, its visible being is what it has done in passing by.

Is anything revealed through such a playful association? At a first approximation it seems that it is possible to map two “regions” which do not coincide, but which in comparison may be discerned to have differing boundaries and horizons. In the “region” of sight there is a

visual field which may be characterized now as “surrounded” by its open horizon which limits vision, and which remains “unseen.” Such a field can be diagrammed (fig. 4.1).

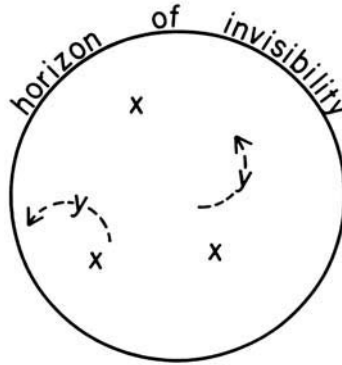

FIGURE 4.1 Horizon of Invisibility

Here, where the enclosed circle is the present visual field, within this presence there will be a vast totality of entities that can be experienced. And although these entities display themselves with great complexity, within the abstraction of the approximation we note only that some are stable (x) and usually mute in ordinary experience, and that some (-y-) move, often “accompanied” by sounds. Beyond the actually seen field of presence lies a horizon designated now as a horizon of invisibility.

A similar diagram can be offered for a “region” of sound presences (fig. 4.2).

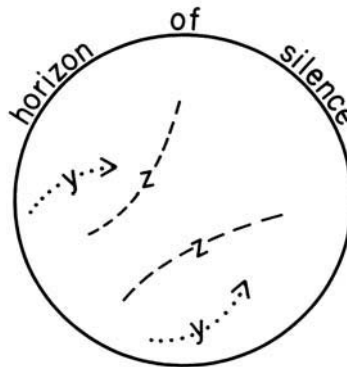

FIGURE 4.2 Horizon of Silence

Although once we move beyond this approximation, the “shape” of the auditory field will need to be qualified. Within the limits of the first approximation we note that the auditory field contains a series of auditory presences which do not, however, perfectly overlap those of the visual field. There are sounds that “accompany” moving objects or beings (-y-), but there are some for which no visible presence may be found (--z--). Insofar as all sounds are also “events,” all the sounds are, within the first approximation, likely to be considered as “moving.” Again, there is also a horizon, characterized by the pairing as a horizon of silence that “surrounds” the field of auditory presence.

It is also possible to relate, within the first approximation, the two “regions” and discern that there are some overlapping and some nonoverlapping features of each “region.” Such a “difference” may be diagrammed (fig. 4.3).

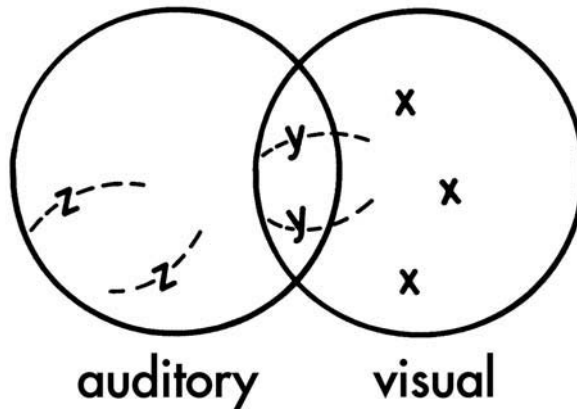

FIGURE 4.3 Auditory-Visual Overlap

In this diagram of the overlapping and nonoverlapping “regions” of sight and sound we note that what may be taken as horizontal (or absent) for one “region” is taken as a presence for the other.

Thus while the area of mute objects (x) seems to be closed to the auditory experience as these objects lie in silence, so within auditory experience the invisible sounds (--z--) are present to the ear but absent to the eye. There are also some presences that are “synthesized” (-y--) or present to both “senses” or “regions.”

This pairing when returned to the reverie concerning the associated “metaphysics” of the “senses” once more reveals a way in which the

traditions of dominant visualism show themselves. If we suppose that any metaphysics of worth must be one that is at least comprehensive, then a total visualist metaphysics must find a way to account for and to include in its description of the world all those invisible events that at this level seem to lie beyond the reach of the visible horizon, but are nevertheless present within experience.

This may be done in several ways. First, one can create some hermeneutic device which, continuing the approximation of the “regions,” functionally makes the invisible visible. This implies some “translation” of one “region” into the terms of the favored “region.” Such is one secret of the applied metaphysics often found in the sciences of sound. Physically, sound is considered a wave phenomenon. Its wave characteristics are then “translated” into various visual forms through instruments, which are the extended embodiments of the scientific enterprise. Voice patterns are “translated” into visual patterns on oscillographs; sound reverberations are mapped with Moire patterns; even echolocation in its practical applications is made a matter of seeing what is on the radar screen: the making or “translating” of the invisible into the visible is a standard route for understanding physics of sound.

In the case of the sciences of sound this translation allows sound to be measured, and measurement is predominantly a matter of spatializing qualities into visible quantities. But in ordinary experience there is often thought to be a similar role for sound. Sounds are frequently thought of as anticipatory clues for ultimate visual fulfillments. The most ordinary of such occurrences are noted in locating unseen entities.

The bird-watcher in the woods often first hears his bird, then he seeks it and fixes it in the sight of his binoculars. The person hanging a picture knows where to look for the dropped tack from the sound it made as it rolled under the piano. And although not all noises yield a visual presence—for example, the extreme case of radio astronomy may yield the presence of an unsuspected “dark” star that may never be seen—the familiar movement from sound to sight may be discerned.

The movement from that which is heard (and unseen) to that which is seen raises the question of its counterpart. Does each event of the visible world offer the occasion, even ultimately from a sounding presence of mute objects, for silence to have a voice? Do all things, when *fully* experienced, also sound forth?

In ordinary experience this direction is also taken. The bird-watcher may be an appreciative bird listener. He awaits quietly in the hopes that the winter wren will sing his long and complicated “Mozart” song. But only

in more recent times has this countermovement become conspicuous. The amplified listening which now reveals the noise of lowly ant societies gives voice to the previously silent. Physically even molecules sound, and the human ear comes to a threshold of hearing almost to the point of hearing what would be incessant noise.³

This page intentionally left blank.

Chapter 5

The Shapes of Sound

The approximation that opened a difference between sight and sound ended in a questioning of the import of that difference. If a movement is possible that gives visibility to the unseen, and a countermovement that gives voice to the mute is possible, a closer listening to the auditory dimension itself is called for. The time has come when listening must begin to be reflective. I begin to take note of my listening, and I first notice a certain incessant field of sound which strikes me as a constant “flux” marked by an obvious and dramatic “temporality.”

I begin to catalog my auditory experience within a given moment of time, and I note that within only a few moments a series of sound-events have occurred. There is the sound of the vacuum cleaner on the floor below; just then there was the pounding of the construction worker next door; the rustle of leaves is heard momentarily; and, if I am more attentive to less obvious sounds, there is the buzz of the fluorescent light and the hum of the heating system. But I also conclude, perhaps too easily and too quickly, that the auditory world is one of “flux” and that it is primarily *temporal*.

I close my eyes and note that one sound follows another, that a single sound “exists” for a moment and “passes away,” and that there is an “inconstancy” to this “region” in which the surging of time is dramatically present. This intimacy of temporality with the auditory experience forms a central tradition concerning sound and may be found recorded by philosophers as diverse in points of view as Søren Kierkegaard, Edmund

Husserl, and P. F. Strawson. What I “discover” first is already known and sedimented as knowledge.

In meditating on music and language as sensuous media Kierkegaard writes,

The most abstract idea conceivable is sensuous genius. But in what medium is this idea expressible? Solely in music . . . it is an energy, a storm, impatience, passion, and so on, in all their lyrical quality.”¹ But also noting the auditory dimension of language he states, “Language addresses itself to the ear. No other medium does this. The ear is the most spiritually determined of the senses . . . aside from language, music is the only medium that addresses itself to the ear.”²

Language and music, auditory phenomena, are understood by Kierkegaard to be dominantly temporal in their actual form. “Language has time as its element; all other media have space as their element. Music is the only other one that takes place in time.”³ This *positive* relation of sound to time is what contextually appears as “first” in a reflective listening. It is also maintained within phenomenology in the use of auditory material in Husserl’s *Phenomenology of Internal Time Consciousness*. Not only are his usual visual examples often and even dominantly replaced in these lectures by auditory ones, but even the use of metaphorical and descriptive language begins to take on an auditory tone. “The bird changes its place; it flies. In every situation the echo of earlier appearances clings to it (i.e., to its appearance). Every phase of this echo, however, fades while the bird flies farther on. Thus a series of *reverberations*’ pertains to every subsequent phase, and we do not have a simple series of successive phases.”⁴ With Kierkegaard, Husserl takes note of the overwhelming intimacy of sound and time.

However, where this is “traditional” concerning sound, and where this strong tie cannot be overlooked in any analysis of auditory experience, there is often either implicitly or explicitly a negative claim that listening is either therefore “weak” spatially or, most extremely, that *sound lacks spatiality entirely*. This negative claim is most blatant in precisely that tradition that most clearly “atomizes” the senses and reduces them to their lowest forms: the empiricist tradition. This view, rapidly losing ground in the biological and physical sciences, sometimes affirms that “a spatial order is connate only for the optical, tactile, and kinesthetic spheres; while for the other senses, mere complexes of feelings with spatial features are admitted.”⁵

Such a view is explicit in Strawson’s *Individuals*. Strawson, clearly defending a “metaphysics of objects” in an Aristotelian vein that continues

the visualism of vision and objectification, considers a “No-Space” world that he finds a conceptual possibility of a reduced world of “pure” sound.

The fact is that where sense experience is not only auditory in character, but also at least tactual and kinesthetic as well—we can sometimes as *sign* spatial predicates on the strength of hearing alone. But from this fact it does not follow that where this experience is supposed to be exclusively auditory in character, there would be any place for spatial concepts at all. *I think it is obvious* that there would be no such place.⁶

What is “obvious” is that a tradition is here being taken for granted with disregard for the contemporary discoveries of very complex spatial attributes to auditory experience. Directionality and location, particularly advanced in such animals as porpoises and bats but not lacking in humans, have shown the degree to which echolocation is a very precise spatial sense. The bat’s ability to “focus” a “ray” of sound such that it may discern the difference between a twig and the moth it is after is now well known. But such auditory abilities have long been encased in precisely the tradition that denies spatiality to listening and for decades and even centuries prevented the scientist from believing that it was indeed a capacity for sound and listening.

Although experiments with bats as early as those of Lazzaro Spallanzani in 1799 led him to ask “whether their ears rather than their eyes serve to guide them in flight.” The already established prejudices of the ancients caused even Spallanzani to doubt his findings. Even the suggestion that hearing could detect and localize objects “in space” was vigorously attacked by eminent figures such as Georges Cuvier and George Montagu. It was not until 1912 that the suggestion that hearing was “spatializable” reopened the question that has led to contemporary knowledge concerning echolocation in a whole series of animals, and that today may lead to the development of amplification devices by which the blind may extend their often already, acute hearing.

It is precisely because of the very “obviousness” *not* of experience, but of the traditions concerning experience that there is reason to postpone what is “first” in the turn to the auditory dimension. Without denying the intimacy of sound and time and without denying the richness of the auditory in relation to temporality, a strategy that begins in approximations is one that must move with extreme care so as not to overlook or fail to hear what also may be shown in the seemingly weaker capacities of auditory experience. Thus as the move into phenomenology proper is made, it is with the *spatiality* of sound that description may begin. Within a spirit of gradual approximations the “weakest” possibilities of sound are to be explored before the “strongest” possibilities.

However, there are several initial qualifications that must be held in mind in beginning phenomenological description in this way. First, the movement from the more abstract approximation that began in the midst of sensory atomism is one that not only increasingly accelerates away from that division of the senses, but one that begins in making thematic what will be called here the first existential level of experience, the level of “greatest naïveté.” For despite the extreme technicality of Husserl’s discussion of identity from *Logical Investigations*, the outcome is one that reaffirms the primacy of the *thing* in naive or first existential experience. It is to *things* that we attend in naive and ordinary experience once we have set aside our layers of beliefs regarding how those things “should” present themselves.

The same applies to auditory experience. Sounds are “first” experienced as sounds of things. That was the sound *of* the jackhammer with all its irritating intrusion. There, it’s Eric calling Leslie now. That was definitely a truck that went by rather than a car. This ease that we take for granted and by which we “identify” things by sound is part of our ongoing ordinary experience. This common ability of listening contains within it an extraordinary richness of distinction and the capacity to discern minute differences of auditory texture, and by it we know to what and often to where it is that our listening refers.

Often we find extraordinary examples of these capacities in the *musical ear*. Beethoven, for example, had such a rich and extraordinary auditory ability, both perceptual and imaginative, that he could compose and imaginatively hear a whole symphony in his head and specifically discouraged anyone from using the piano to demonstrate passages, because the piano was much poorer than the whole symphony in his head. But this musical, perceptual memory, though not equally acute, is not rare among accomplished musicians.

Such musical feats are also potentially misleading, because there is also a tradition, echoed above by Kierkegaard, that music is “abstract.” Even phenomenologists have been misled to take the musical experience as one that is disembodied and “separated from its source” as a kind of “pure” auditory experience.⁷

In daily concerns such abstract listening is at least unusual, yet its feats of discernment are highly discriminating. On walking along a village street in Llangefni, Wales, my son pointed out a thrush busily banging a snail against the sidewalk. This act soon successfully produced a tasty meal even without benefit of garlic and butter. Several weeks later I was awakened in our house in London to the early morning unmistakable cracking of the snail shell coming through the curtained window. I drew the curtains to show my wife this occurrence, which was new to her, but the “identification” had been quite “obvious” to me by the single sound of the cracking snail shell.

Such identifications and discriminations of minute auditory differences are not as yet “spatial.” But having made a turn of attention to the first naive existential level of experience where sounds are the sounds of things, the spatial aspects of that experience may begin to show themselves. In searching out the spatiality of sound the cautions previously noted take specific form here. First, auditory spatiality must be allowed to “present itself” as it “appears” within this level of experience. Negatively, a predefinition of spatiality such that it is prejudged “visualistically” must be suspended.

Second, affirming the phenomenological sense of the global character of primal experience, it is necessary to replace the division of the senses with the notion of a *relative focus* on a dimension of global experience such that it is noted only against the omnipresence of the globality. Thus a “pure” experience is eliminated and made impossible. Primitively things are always already found “synthesized” in naive existential experience. The move to a focus-fringe interpretation of global experience thus safeguards the tendency toward disembodiment that tempts all “Cartesian” type’s of philosophy, and mixes, in spite of itself, perceptual and emptily suppositional terms.

Third, as a first phenomenological approximation in contrast to the approximation in the midst of sensory atomism, it should be noted that even the division of space and time are not, strictly speaking, primitive experiential significations. Existentially there is a concrete space-time that is also a signification of naive experience in its thematized appearance.

With this second approximation, the entry into the “weakness” of the auditory dimension, phenomenological description proper begins. The provisional character of the sounds of things in ordinary experience should not be considered a final but a first level of the phenomenological experiential analysis.

SHAPES, SURFACES, AND INTERIORS

At the experiential level where sounds are heard as the sounds of things it is ordinarily possible to distinguish certain *shape-aspects* of those things. The following variations begin in what for human hearing is admittedly one of the weakest existential possibilities of listening. I do not claim that every sound gives a shape-aspect (but neither does every sighting give a shape-aspect in the ordinary sense). At first such an observation seems outrageous: *we hear shapes*.

The shape-aspects that are heard, however, must be strictly located in terms of their auditorily proper presentation and not predetermined or prelimited by an already “visualist” notion of shape. The shape-aspects that

are heard are “weaker” in their spatial sense than the full outline shape of a thing that is ordinarily given all at once to vision. But a “weakness” is not necessarily a total absence, for in this “weakness” there remains an important, if primitive, spatiality for hearing.

Children sometimes play an auditory game. Someone puts an object in a box and then shakes and rolls the box, asking the child what is inside. If, more specifically, the question is directed toward shapes, the observer soon finds that it takes little time to identify simple shapes and often the object by its sound. For example, if one of the objects is a marble and the other a die (of a pair of dice), and the box is rolled, the identification is virtually immediate. The difference of shape has been *heard*, and the shape-aspect has been auditorily discriminated.

But the flood of likely objections to such an observation, however experientially concrete such examples are, threatens to overwhelm the listener. For in spite of the hermeneutic rules of *epoché* that attempt to put out of play both “sensory atomism” and its preferred “visualism,” it threatens to return at each stage of analysis. It is precisely the recalcitrance of such beliefs that makes the act of auditory discernment “difficult to believe” in spite of one’s ears.

The point here is not to enter into an interminable and difficult argument but to let the things show or sound themselves. For involved in the “weakness” of auditory spatiality there are a number of factors that allow that “weakness” to be missed if one is not careful in listening. What is amazing, however, is what appears spontaneously in the simple variation. The very first time I played this game with my son I had placed a ballpoint pen in a box without his seeing it and rolled it back and forth. I asked him what shape it was. His answer was, “It’s like a fifty-pence shape, you know, on its sides, only it’s longer.” A fifty-pence coin has seven sides, the ballpoint pen had six, and it was, in his parlance, “longer.”

The shape-aspect is not the only thing that is given in the richness of simple auditory presentations. If the game is allowed to continue so that one learns to hear things in an analogue to the heightened hearing of the blind man’s more precise listening to the world, a quickly growing sophistication occurs. A ballpoint pen gives a quite different auditory presentation with its plastic click from that of a wooden rod. A rubber ball is auditorily distinct from a billiard ball as it is visually distinct. The very texture and composition as well as the shape-aspect is presented in the complex richness of the event.

It is often this learning itself that offers itself as suspicious to the “sensory atomist” whose notion of a built-up or constructed knowledge also infects his understanding of learning. Phenomenologically there is a great

distinction between *constructing* something and its *constitution*. In constitution the learning that occurs is a learning that becomes aware of what there is to be seen or heard. There is the usual inversion called for in *epoché* here. As Merleau-Ponty remarked, "*Learning is In der Welt Sein*, and not at all that *In der Welt Sein is learning*."⁸ This difference may be illustrated by two vastly different ways in which perceptual experience is employed in the empirical sciences.

In some psychology many of the experiments are deliberately designed to first disrupt all previous "learning" by radically altering its context. To view a white sheet of paper under blue lighting through a darkened tube that cuts off the normal context and field significance of the experience is to radically alter ordinary experience. But the learning which is tacit in ordinary experience is then further cut off by allowing the experience to continue for only an atom of time, thus preventing any adjustment. In this way the experiment is set up so that it often cannot help but circularly reinforce the "abstraction" of the "sensory atomist's" view of perception that begins with the "abstraction" of "sense data" or similar "stimuli." The experiment constructs the condition for the preformed conclusion and interprets what it finds as *a primitive* of experience.

Yet the always-present learning through which perceptions are incarnate functions here as well; only in this case it operates tacitly in the situation of the observer, the psychologist. Were she to be replaced by another observer as experimentally "naive" as her subject, in all likelihood there would be little purpose to or knowledge resulting from the experiment. The observer would still have to enter the scene even if now her taken-for-granted judgments are removed one step further.

There is a sense in which the role of constitution proposed by the phenomenologist is implicitly recognized in the natural sciences. An ornithologist friend once described to me the pains he had to go through to get his first-year students to even produce a recognizable description of bird behavior. He would lapse into laughs when a report returned stating, "The bird *sat* on the fence, then it hopped and sat again." For in his parlance a bird not only does not sit, it perches; but the student in this case had not yet learned to see. At first the learner does not recognize the differences between the various species of warblers, which are often confusing anyway, but after long and careful learning he then wonders why he could not at first recognize what is now so obvious.

But the learning does not *construct* what is to be seen, it *constitutes* it in terms of its meaning. What is to be seen is *there*, and anyone entering this region of knowledge may see the distinctive marks that differentiate one warbler from the other. Once the distinctions have been learned, the previous

lack of awareness and lack of discrimination is seen not as a fault of the “object” but of the inadequacy of our own prior observation.

This problem is partially due to our frequent failure to discern the space-aspects of auditory experience. We have not learned to listen for shapes. The whole of our interpretation in its traditional form runs from it, and only in the dire situation of being forced to listen for shapes, such as the advent of blindness, do ordinary men attend specifically to the shape-aspects of sound.

But even here there is a complication that arises from the global or plenary quality of primary experience. For the blind or deaf person experiences his “world” as a unity and his experience as a plenum. His sense of lack is conveyed by the transcendence of language, and he even becomes quite adept at “verbalisms,” the ability to define things through words, although he may not recognize them when they are presented to him. One blind person describes this sense.

Those who see are related to me through some unknown sense which completely envelops me from a distance, follows me, goes through me, and, from the time I get up to the time I go to bed, holds me in some way in subjection to it.⁹

It is here that the “sensory atomist” finds so much “evidence” for his constructionist view of the world. It is well known that many, indeed most, persons who are blind cannot visually recognize certain objects presented to them until they feel these objects. But there is another possible interpretation of such “evidence.” It is not that the object is built up, but that the learning that goes on in all experience must go on here, too. The radically new experience of seeing, when a blind person gains sight through a medical procedure, is revealing. His *first* sight, when reported, often turns out to be precisely “like” those first impressions reported in the first turn to reflective *listening*. He is impressed by what we might call the *flux* and *flow*, the implicit temporality of the new dimension to his experience. J. M. Heaton reports that when the blind are given sight, “at first colours are not localized in space and are seen in much the same way as we smell odours.”¹⁰ Odors, sounds, tastes, on *first* note, appear not as fixed, but as a flux and flow. The first look is a stage of experience, not something that belongs isolated within one “sense.”

This learning is often painful. For the patient it is not a mere addition to his experience but a transformation of the whole previous shape of the plenum of his experience.

The chief difficulty experienced by these patients is due to the general re-organization of their existence that is required, for the whole structure of their world is altered and its centre is displaced from touch to vision; and not only perception but language and behavior also have to be reoriented.¹¹

It is not, however, that on being given sight spatiality is first discovered. It is *reconstituted*. A subtle example of this was given to me by a student trained in phenomenology who had been blind, but who, through treatment, gained limited sight. She noted that one quite detectable difference in her lived spatial organization when given sight was a gradual displacement of a previously more omnidirectional orientation and spatial awareness to a much more focused *forward* orientation. Although she noted that even when blind there was a slight “preference” for a forward directed awareness, this became much more pronounced with the gaining of vision.¹² Again, as will become more apparent as the spatial significations of the auditory dimension become more pronounced, the relative omnidirectionality of awareness and orientation is “closer” to the space-sense of sound than that of vision.

In a gradual clarification of the distinctive spatial sense of auditory experience, the first discrimination of shape-aspects heard in such spontaneous experiences as that of the game of placing an object in a box becomes more precise when attention is paid not only to the presence of the spatial aspect, but to how it is given in perception. Reverting to the pairing of sight and sound, this factor becomes easier to locate.

I turn to my visual and auditory experiences. I note now that in both dimensions there is a multiplicity of phenomena, but I also note that these do not always overlap. I see before me the picture of the sailboat, the note concerning last night’s sherry party, a postcard from Japan. But I hear the cement mixer, the bird song, and the traffic in the street.

Next, I note that it seems at first that every stable thing before me visually presents a spatial signification which is, moreover, given-all-at-once. Each object has at least an *outline shape*, and this shape in the objects mentioned is discerned immediately. But of the sounds I do not seem to get shapes, certainly not outline shapes and certainly not all-at-once.

In comparing this nonoverlapping of shape in sight and sound in terms of the question of how shape-aspects are given, I soon find that the question of time is involved as well. The all-at-onceness to the outline shape before me is a matter of *temporal instantaneousness* or of *simultaneity*. But when I return to those experiences which give me shape-aspects I find that the one given is not a matter of instantaneousness but of a *sequential*

or *durational* presentation. If the ball is dropped and does not bounce, I may not get more than a “contact point” as a vague and extremely “narrow” signification. But if the ball is rolled for several instants, if the rolling endures through a time span which is quite short, I get a sense of its shape as an *edge-shape*. This shape is presented not in terms of temporal instantaneity but in terms of temporal duration. In both cases there is a need for some “time,” as even visually the object presented in too small an atom of time remains equally spatially indiscernible. But there is a difference of need here in which the temporal duration for the discrimination of an edge-shape by sound must be relatively greater. Here again a clue seems to emerge as to why tradition has maintained the asymmetries of “spatial poverty” for sound and “temporal richness” for sound in comparison to the “spatial richness” and “temporal poverty” for sight.

But this comparative variation bespeaks only one, albeit important, variation in relation to spatial significations, and with it the sedimentation of the dominance of the mute object for spatial significations remains. Further variations, however, tend to diminish the asymmetries to a degree. If I return to the pairing of sight and sound and introduce the (rapidly) moving thing into experience, a difference occurs. The arrow, the drop of water, the stone that appear before me falling or flying at certain speeds do not show themselves as clear and distinct shapes. They present themselves as “vague” shapes that reveal themselves only when the motion stops. (In some cases this can happen if the field is large enough and the speed slow enough for me to fix my eyes upon an object as it moves.) Some form of *fixing* is required to determine the clarity and distinction of the outline shape. Once again the stable and mute object returns as the hidden norm of visualist space significance.

Yet the “weak” or “vague” shape-aspect of the moving object is closer to the many shape-aspects which auditory experience yields in its constant flux. A duration is needed to discriminate shape in this constant motion. Thus if “extended,” temporal duration which persists in the flux and motion of sound in time is what appears as the main presentational mode of heard shape-aspects. The much shorter and more “instant” norm of visual stability allows duration to be either overlooked or forgotten and thus apparently to be less important in the visual discrimination of spatial significance.

An edge-shape is “less” than the outline shape, but it is a shape-aspect nonetheless. It is as if the ear had to gradually gain this shape in its durational attention. It is from such temporal considerations that “linear” time metaphors may arise. In this respect auditory shapes seem on one side to be closer to tactile shape discriminations. The blind Indian who concludes that the elephant is like a snake, and who argues with another who thinks the ele-

phant is like a rough wall, is not wrong but inadequate in his “observations” concerning the shape of the elephant. Were he a rigorous feeler of elephants he would not be satisfied with instant apodicticity but would withhold his conclusion until he had covered the whole surface of the elephant. So, with listening for shape-aspects it often takes repeated and prolonged listenings until the fullness of the shape appears. This serves no useful purpose in daily affairs when a mere glance will do the same in less time. Thus we fail to hear what may be heard and pass over an existential possibility of listening.

A third variation shows that there is even less absolute difference between sight and sound when size is taken into account. The edge-shape is usually admittedly quite “small.” The marble rolling in contact with the box or the die striking the box presents only a small aspect of itself. But visually there is a reversion to a sequential discrimination, too, if the thing is immense. If one stands below the skyscraper, it is unlikely that he will take in the whole at once. He allows his gaze to follow the outline of the building, and the gaze in relation to the vastness becomes a sequential following of the outline-shape. The all-at-onceness does again become possible if distance is increased, as, for example, when I see the whole skyscraper from above while stuck in a traffic pattern in an airplane above Manhattan. Again the comparative reign of the now “middle-size” stable and mute object returns, and the comparative “weakness” and difficulty of auditory shape discrimination returns; but only now it is understood as a matter of relative distancing in space-time. It remains the case that the shape-aspect which is discerned auditorily in its “weakest” possibility is a spatial signification which is limited to a degree within the dimension of hearing.

There is another factor of the hearing of shapes which reveals itself in the “weakness” of hearing the shape of the thing: one that raises the question of *how* the thing is *voiced*. The mute object does not reveal its own voice, it must be given a voice. In the examples listed, for the most part, a voice is given to the object by some other object. One thing is struck by another, one surface contacts another, and in the encounter a voice is given to the thing.

There is clearly a complication in this giving of voice, for there is not one voice, but *two*. I hear not one voice, but at least two in a “duet” of things. I hear not only the round shape-aspect of the billiard ball rolling on the table, I also hear the hardness of the table. The “same” roundness is heard when I roll the billiard ball on its felt-covered table, but now I also hear the different texture of the billiard table. True, just as in listening to an actually sung vocal duet, I can focus auditorily on either the tenor or the baritone; but my focal capacity does not blot out the second voice, it merely allows it to recede into a relative background. Thus in listening to the duet of things which lend each other a voice, I also must learn to hear what each offers in

the presence of the other. The way in which the mute things gain or are given voices in my traffic with the world is an essential factor in all spatial signification in sound. The voices of things call for further attention.

Although only a massive shift in perspective and understanding will ultimately allow the fullness of auditory spatial significations to emerge, the movement from weaker to stronger possibilities of listening is one that increases our familiarity with such significations. Less strange than the notion of hearing shapes, *we also hear surfaces*. This auditory experience is involved with our ordinary experiences of things.

Who does not recognize the surface in the sound of chalk scratching? I hear footsteps in the hallway. (I can tell if it is Leslie in her heels or Eric in his tennis shoes) or, when the walker steps on the tile its surface produces a characteristic clacking sound of hard heels. Then, the moment the person first steps into the living room the clacking changes to the dull thudding sound of footsteps on the rug.

Surfaces, which are more familiar to us than shapes, must also be heard in terms of a voice being given the things. Just as in the discernment of shape-aspects (and shape-aspects may grade off into surface significations) there is usually a duet of voices in the auditory presentation. Furthermore, there is often more than a surface signification, a signification that grades off at the upper end into an anticipation of hearing interiors. I hear the textural and compositional character of the thing and distinguish easily between the sound of a bell and that of a stick hitting pavement.

Unaccustomed as we are to the language of hearing shapes and surfaces, we may remain unaware of the full possibilities of listening. But the paradigm of acute listening given in the auditory abilities of the blind man often provides clues for subtle possibilities of the ordinarily sighted listener as well. The blind man through his cane embodies his experience through a feeling and a hearing of the world. As Merleau-Ponty has pointed out, he *feels* the walk at the end of his cane. The grass and the sidewalk reveal their surfaces and textures to him *at the end of the cane*. At the same time his tapping which strikes those surfaces gives him an auditory *surface-aspect*. The concrete sidewalk sounds differently than the boardwalk, and in his hearing he knows he has reached such and such a place on his familiar journey.

To be sure, the surfaces heard by the blind man or the ordinary listener are restricted surfaces. They lack *the expanse* which vision with its secret "Cartesian" prejudice for "extension" presents, because the auditory surface is the revelation of an often small region rather than the spreading forth of a vista. But within its narrowness a surface is heard.

But striking a surface and thereby getting a duet of the surface aspects of two things is not the only way in which the mute object is given voice,

nor is it the only way in which sound reveals surfaces. For the blind man's tapping also gives an often slight but nevertheless detectable voice to things in an *echo*. *With the experience of echo, auditory space is opened up.* With echo the sense of distance as well as surface is present. And again surface significations anticipate the hearing of interiors. Neither, in the phenomenon of echo, is the lurking temporality of sound far away. The space of sound is "in" its timefulness.

The depth of the well reveals its auditory distance to me as I call into its mouth. And the mountains and canyons reveal their distances to me auditorily as my voice re-sounds in the time that belongs so essentially to all auditory spatial significations. But these distances are still "poorer" than those of sight, though distances nonetheless. This relativity of "poverty" to "wealth" is apparent in the occasional *syncopation* of the visual and auditory appearances of the thing. Such a common experience today may be located in the visual and auditory presentations of a high-flying jet airplane. When I hear the jet I may locate its direction quite accurately by its sound, but when I look I find no jet plane. The sound of the jet trails behind its visual appearance and, by now accustomed to this syncopation, I learn to follow the sound and then look ahead to find the visual presence of the jet.

But as I come to smaller distances the syncopation lessens, and the sight and sounds converge so that ordinarily the sight and sound of the things seem to synthesize in the same place. Yet with careful attention as I stand in the park and listen to the automobiles and trucks rush past, I find that even here there is a slight trailing effect. I close my eyes and *follow* the sound which, on opening my eyes, I find only slightly trails the source as seen. Soon I can detect this trailing with my eyes open. Again in this distance the temporality of sound is implicated.

This often unpracticed and unnoticed form of human echolocation which is spatially significant may also be heightened. For the echo in giving voice to things returns to us with vague shapes and surfaces. The ancient theory of vision that conceived *of a ray* proceeding from the eye to the object and back again is more literally true for the sounding echo's ability to give voice to shapes and surfaces. The blind man, who has learned and listened more acutely than we, produces this auditory "ray" with his clicking cane. Yet anyone who listens well may hear the same.¹³

I repeat the experience of the blind man, carrying with me a clicking device. As I move from the bedroom to the hall a dramatic difference in sounding occurs, and soon, as I navigate blindfolded, I learn to hear the narrowing of the stairs and the approaching closeness of the wall. Like the blind man I learn to perceive auditorily the gross presences of things. But in the relative poverty of human auditory spatiality I miss the presence of

the less gross things. I cannot hear the echo which returns from the open-backed Windsor chair, but I do discern the solid wall as a vague presence. Yet in a distance not too far from human experience, I know that the porpoise can auditorily detect the difference of size between two balls through his directed echo abilities, a difference that often escapes even the casual glance of a human.

I listen more intently still. The echo gives me an extremely vague surface presence. I strike it and its surface resounds more fully. Yet even in the weakness of the echo I begin to hear the surface aspects of things. I walk between the Earth Sciences building with its concrete walls along the narrow pathway bounded on the other side by the tall plywood walls fencing off the construction of the new Physics building. In the winter the frozen ground echoes the click of my heels, and I soon know when I have entered the narrowness of the pathway. Once at the other end the sound "opens up" into the more distant echoing of the frozen ground that stretches to the parking lot. But as the days go by and I listen, I soon learn that not only is there a surface presence, not only is there the "opening" and the "narrowing," but there is also a distinctly different echo from the concrete wall and the plywood fence. The surface-aspect only gradually becomes less vague in the sharpening of our listening abilities. In the echo and in the striking of the thing, I hear surfaces as existential possibilities *of* listening.

While there is no question here of exhausting even the relative and often vague "poverty" of shape and surface aspects, the march toward the "richness" within sound must continue. It is with a third spatial signification that this "richness" begins to appear, for, stronger than shapes and more distinct than surfaces, I *hear interiors*. Moreover, it is with the hearing of interiors that the possibilities of listening begin to open the way to those aspects which lie at the horizons of all visualist thinking, because with the hearing of interiors the auditory capacity of making present the *invisible* begins to stand out dramatically. To vision in its ordinary contexts and particularly within the confines of the vicinity of mute and opaque objects, things present themselves with their interiors *hidden*. To see the interior I may have to break up the thing, do violence to it. Yet even these ordinary things often reveal something of their interior being through sound.

A series of painted balls is placed before me. Their lacquer shines, but it conceals the nature of their interiors. I tap first this one, and its dull and unresounding noise reveals it to be of lead or some similar heavy and soft metal. I strike that one, and there is no mistaking the sound of its wooden interior. The third resounds almost like a bell, for its interior is steel or brass. In each case the auditory texture is more than a surface presentation it is also a threshold to the interior.

I am asked to hang a picture in the living room. Knowing that its weight requires a solid backing, I thump the wall until the hollowness sounding behind the lathed plaster gives way to the thud that marks the location of the stringer into which I may drive my nail. What remained hidden from my eyes is revealed to my ears. The melon reveals its ripeness; the ice its thinness; the cup its half-full contents; the water reservoir, though enclosed, reveals exactly the level of the water inside in the sounding of interiors. Hearing interiors is part of the ordinary signification of sound presence and is ordinarily employed when one wishes to penetrate the invisible. But one may not pay specific attention to this signification as the *hearing* of interiors unless one turns to a listening “to the things themselves.”

In the movement from shape-aspects to surfaces to interiors there is a continuum of significations in which the “weakest” existential possibilities of auditory spatial significations emerge.

In all of this listening there is a learning. But that learning is like that of the blind man first being given sight; he does not at first know what he sees. Neither do we know what we hear, although in this case what is to be heard lies within the very familiarity with things in their present but often undiscovered richness. But once we learn to hear spatial significations, the endless ways in which we hear interiors comes to mind. We hear hollows and solids as the interior spatiality of things. We hear the *penetration* of sound into the very depths of things, and we hear again the wisdom of Heraclitus, “The hidden harmony is better than the obvious.”¹⁴

In the reverberation of a voice given to things by the striking of one thing by another, in the echo that gives a voice to things, and in the penetration that exceeds the limits of visible space is experienced what is possible for listening. Its presence may occur in the turning of an ear. I go to a concert, and the orchestra plays before me. Suddenly the auditorium is *filled* with music. Here, Baudelaire noted that music gives the idea of space. For now the open space is suddenly and fully present, and the richness of the sound overwhelms our ordinary concerns with things and directions. But even here there lurks just behind us the relative emptiness and openness that the echo reveals. I turn my head sidewise as the music pours forth, and suddenly, dramatically, I hear the echo that lay hidden so long as the orchestra enveloped me with what is sounding before me. And in the echo I hear the interior shape of the auditorium complete even to its upward slant to the rear. The echo opens even filled space, and in hearing there is spatial signification. But let each person listen for himself.

This page intentionally left blank.

Chapter 6

The Auditory Field

We listen first to things. They capture our attention in their voices and are the “naive” or first existential sources of the sounding which we hear. Yet without forgetting this first presence of the existentiality of the thing, the concern of phenomenology must also be expanded beyond any exclusive concern with things alone. To simply take the thing alone without raising the wider question of how things present themselves in terms of a situated context is to allow the illusion of a thing-in-itself to occur. The thing never occurs simply alone but within a field, a limited and bounded context.

The question of an *auditory field* has already been proximately anticipated in the observation that all things or occurrences are presented in a situated context, “surrounded” by other things and an expanse of phenomena within which the focused-on things or occurrences are noted. But to take note of a field as a situating phenomenon calls for a deliberate shifting of ordinary intentional directions. The field is what is present, but present as implicit, as fringe that situates and “surrounds” what is explicit or focal. This field, again anticipatorily, is also an *intermediate* or eidetic phenomenon. By intermediate we note that the field is not synonymous with the thing, it exceeds the thing as a region in which the thing is located and to which the thing is always related. But the field is also limited, bounded. It is “less than” what is total, in phenomenological terms, less than the World.

The field is the specific form of “opening” I have to the World and as an “opening” it is the particular perspective I have on the World. It is an

existential structure in that all things that present themselves do so within the field—the field “transcends” things—but the field itself is not synonymous with World. The question of World in the full ontological sense, however, arises only fully with the question of horizons that in turn “surround” and “transcend” the field of presence.

Thus the field as an intermediate eidetic phenomenon is an existential structure, no longer at the level of things as such but not yet that which allows a comprehensive apprehension of the World as lifeworld to emerge. That apprehension occurs only at the limits of phenomenology. But the second level of investigation calls for a preliminary survey of the shape and structures of the auditory field as a type of “opening” to the World.

In isolating field characteristics the temporary suspension of the first existential attention toward things must occur. Attention is turned to what is indirect and implicit when compared to the ordinary involvements with focal things. Phenomenological attention moves outward, recapturing a possibility of the focus-fringe ratio anticipated in the first approximations to the field phenomenon. But this move away from things in order to explicate and describe the field phenomenon does not abandon the existential possibilities of things so much as it performs its purposeful inversion of attention in order to return to a more adequate sense of existentiality once the field is described.

Beginning once more with a device, an approximation as first introduced in a “visualist” form of certain features of intentionality, the question now becomes one of the auditory dimension. Once more the abstract device of pairing approximate fields offers an initial entry into what must become a more comprehensive survey of auditory field characteristics.

When the question of paired field phenomena is raised, there appear a number of *functional* similarities concerning the relative forms of the visual and auditory “openings” to the World. I note comparatively that those experiences that reveal the structure of focus to fringe with a variable ratio of relativity between them occur auditorily as well as visually. In listening to a symphony, if for some special reason I care to do so, I find I can focus on the strains of the oboe in spite of the louder blaring of the trombones (at least within limits). The city dweller hears the clink of the coin on the subway platform even as the train approaches, and the jungle dweller hears the whisper of the adder in spite of the chatter of monkeys and parrots. I can select a focal phenomenon such that other phenomena become background or fringe phenomena without their disappearing. Moreover, this attention is keyed into the personal-social structures of daily life in such a way that there are habitual and constant patterns of appearance to those things that normally remain fringe phenomena and those that may be

focal. I go to the auditorium, and, without apparent effort, I hear the speaker while I barely notice the scuffling of feet, the coughing, the scraping noises. My tape recorder, not having the same intentionality as I, records all these auditory stimuli without distinction, and so when I return to it to hear the speech re-presented I find I cannot even hear the words due to the presence of what for me had been fringe phenomena. The tape recorder's "sense data" intentionality has changed the phenomenon.

In daily *affairs* this focus-fringe ratio constantly shifts with interests and occasions. In this the variability of focal intentionality functions "like" its visual occurrence. But when the *shape* of that focus is noted, there immediately appear certain striking differences as well. Within the visual field, focus displays itself as a central vision within the field. To turn my focus, I turn my eyes, my head, or my whole body. The visual field, moreover, displays itself with a definite *forward oriented* directionality. It lies constantly before me, in front of me, and there it is fixed. As a field relative to my body it is *immobile* in relation to the position of my eyes, which "open" toward the World. Noted also was the vague, though noticeable horizon which imparts a *roundish shape* to the visual field. Thus as a field, the visual "opening" to the World has a concretely directed and determined spatiality relative to bodily position.

When this set of determinations of the visual field is paired with that of the auditory field, the differences of dimension begin to occur. First, the auditory field as a *shape* does not appear so restricted to a forward orientation. As a *field-shape* I may hear all around me, or, as a field-shape, sound *surrounds* me in my embodied positionality. I am sitting at my desk, and I hear my wife approaching up the steps. She enters the study and speaks to me from the doorway to the left and behind me. I turn to greet her, but she has first been present and noted from behind in the sounding of her feet. I catalog my auditory experiences and note that the ticking of the clock comes from the right, the hiss of the radiator from the left, the hum of the light from above, and the wag of Josephine's tail from under the table. All of these sounds occur simultaneously and "fill" the auditory field with their complex multiplicities.

I also note that I can switch my focal, auditory "ray" from one sound to another without even turning my head. I can discern that the sound from the right and behind is that irksome whine of the stove fan motor. My auditory field and my auditory focusing is not isomorphic with visual field and focus, it is *omnidirectional*. In the shape of the auditory field, as a surrounding thing, the field-shape "exceeds" that of the field-shape of sight. Were it to be modeled spatially, the auditory field would have to be conceived of as a "sphere" within which I am positioned, but whose "extent"

remains indefinite as it reaches outward toward a horizon. But in any case as a field, the auditory field-shape is that of a surrounding shape. This shape may often be quite dramatically located and discerned when the field is most *full*, as in the presence of a full and dramatic moment of symphonic music. If I hear Beethoven's Ninth Symphony in an acoustically excellent auditorium, I suddenly find myself *immersed* in sound that *surrounds* me. The music is even so *penetrating* that my whole body reverberates, and I may find myself absorbed to such a degree that the usual distinction between the senses of inner and outer is virtually obliterated. The auditory field surrounds the listener, and surroundability is an essential feature of the field-shape of sound.

But if the dramatic presence of symphonic music reveals at a stroke what the poorer cataloging of separate direction possibilities also shows in regard to the omnidirectionality of sound presence, this dramatic presence can also hide another aspect of the auditory field. For while one essential possibility of the auditory field is the filling of its spatiality as in the case of dramatic music, there are other times when there occurs a *relative* emptiness.

I go for a walk and stand in the middle of a vast park in the north of London. To one side there is a roadway now filled with the evening traffic. The honks and roar of lorries, buses, and small but exceedingly noisy European cars *fill that side* of the auditory field. The other side is *almost* silent, or at least relatively quiet. For while the field of sound surrounds me, it does not do so with anything like a constant homogeneity. Visually, however, if I consider color as a constant variable, I find no "place" in the entire visual field that is empty or even relatively empty. The colorful plenum of the visual field remains constantly full. But the relative and contrasting quiet to "one side" of my auditory field presents a shifting of sound within that field such that what is "full" and what is "rarified" may variably flow within the omnidirectionality of the field as an overall possibility.

This nonhomogeneity, however, is most precisely located at the other end of the spatial signification of the auditory field in the experience of *directionality*. For whether or not I am correct about the source of the sound, and in spite of the syncopation of the visual and auditory appearances of the thing when the distance is great enough, there is the clear phenomenon of directionality within the auditory field. I hear the car coming from behind me, and I jump to avoid it. The jays calling are doing so from the direction of the locust tree. Even in the presence of the orchestra the cough comes from the right.

The clear directionality of sound, however, is not always recognized in our speech. It is recognized insofar as it retains its proper naïveté while embedded in a concern for things. "The bird is over there, I heard him call."

“He must be behind the house, I heard him working there.” Yet until very recent times we have not accurately determined this language in terms of directional spatiality to the degree that visual language allows. But the invention of amplification and sound reproduction instruments has begun to make this language usable. Speakers of philosophical language, which is often as sedimented as ordinary language, might balk at the usage that describes one sound as being *to the right of* or *to the left of* or *above* or *below* another sound. Yet experientially sounds may be discerned in just this way, and the avid stereo and electronics fan already uses this descriptive language. We no longer find it odd that the sound from the right (speaker) is flawed or out of balance with that from the left, and the sounds from a demonstration record that march across the room are sounds that *move from the left to the right*. The field-shapes of sound include both directionality and surround ability.

Here an enigma of the auditory field emerges from these two dimensions of field spatiality; both the global, encompassing surroundability of sound, which is most dramatic and fully present in overwhelming sounds, and the often quite precise and definite directionality of sound presence, which is noted in our daily “location” of sounds, are *constantly copresent*. For the description to be accurate, both surroundability *and* directionality must be noted as copresent. This “double” dimensionality of auditory field characteristics is at once the source of much ambiguity and of a specific richness that subtly pervades the auditory dimension of existence.

A closer examination of the bidimensionality of auditory field-shape shows that there is a certain variability that auditory focusing can reveal in relation to the copresence of surroundability and directionality. The contrast of the musical experience with everyday listening points to two such variations of focal attention. Quite ordinarily, sounds are taken directionally. The hammering from next door is heard *as from* next door. The sparrow’s song in the garden presents itself *from* the garden. But if I put myself in the “musical attitude” and listen to the sound as if it were music, I may suddenly find that its ordinary and strong sense of directionality, while not disappearing, recedes to such a degree that I can concentrate on its surrounding presence.

Contrarily, when listening to the orchestra and in the highest moments of musical ecstasy, I can (perversely, perhaps) by an act of will also raise the question of directionality; and while I continue to be immersed in the sound, there also emerges a stronger sense of direction.

Both these dimensional aspects of auditory presence are constant and copresent, but the intentional focus and the situation varies the ratio of what may stand out. There is also a noematic difference in relation to what kind of sound may most clearly present itself as primarily surrounding and

primarily directional without losing its counterpart. In his experiments with hearing, Georg von Békésy has shown that the sense of directionality is much more precise with clicking sounds than with tones. Constant tones, even modulating tones, show forth more dramatically the encompassing and less directional presence of sound. The clicking “language” of the porpoise, the tapping of the blind man’s cane, the ping of sonar for directionality and location are not accidental but learned selections from the realm of sound for the type of sound appropriate to the highest degree of directional intentional fulfillment. Contrarily, the use of melody, tone, and the flow of music enhances the purposeful seduction of musical presence.

Both these qualities of sound are used simultaneously in what is a most normal human activity, *face-to-face speech*. The other speaks to me in the “singing” of the human voice with its consonantal clicklike sounds and its vowel tonalities. It is a singing that is both directional and encompassing, such that I may be (auditorily and attentionally) *immersed* in the other’s presence. Yet the other stands *before* me. Speech in the human voice is between the dramatic surroundability of music and the precise directionality of the sounds of the things in the environment.

It is in this range of variable presence and focus that the distance between musical experience, often taken as an exceptional experience, and the experience of sounds as primarily the sounds of things that are “located” in a place appears. The seductivity of a “pure sensuousness” in Mozart’s music described by Kierkegaard finds support, but with a different ground here.¹ In the overwhelming presence of music that fills space and penetrates my awareness, not only am I momentarily taken out of myself in what is often described as a loss of self-awareness that is akin to ecstatic states, but there is a distance from things. The purity of music in its ecstatic surrounding presence overwhelms my ordinary connection with things so that I do not even primarily hear the symphony as the sounds of the instruments. But the flight of music into ecstasy is quickly lost if the instrument intrudes as in the case of having to listen to the beginner whose violin squeaks and squawks instead of sounding in its own smooth tonality.

This ecstasy is also the occasion for an illusory phenomenon, the temptation toward the notion of a pure or disembodied sound. In the penetrating totality of the musical synthesis it is easy to forget the sound as the sound of the orchestra and the music floats through experience. Part of its enchantment is in obliteration of things. A countervariable illustrates this: a philosopher friend who now knows he is going deaf told me that he first noticed this ailment when he experienced loss of interest in music. He described the music as becoming “distant . . . objectlike . . . over there apart from me.” It had begun to lose its surrounding, penetrating quality for him.

There is, however, a positive point to be made as well concerning the experience of musical ecstasy and the way in which musical sound does form a gestalt. What disappears in the symphonic presentation is the sense of the separate and discrete “individuals,” at least in a relative sense. The “instrument” that sounds is the entire orchestra united in sound. The surrounding, penetrating quality of sound maximizes larger unities than individuals as such.

Conversely, the hunter intent on bagging his game misses the musical sonority of the birdsong, not because it isn't there, but because it is the direction and location of his prey which motivates him. So, too, with most daily concerns, directionality is that which stands out and is sufficient for ordinary affairs. The continued attempts to enhance musical surroundability continues in technological society in the move from two- to four-channel stereo production in the hope of embodying even more fully the omnidirectional surroundability of musical sound, while in the refinements in all types of echolocation down to the sonic probes of the earth itself or the sonic probe *of* a diseased eye with a minisonar to discover a detached retina, there occurs the precise determination of directionality and shape.

It is in the ordinary babbling traffic that we have with others where the ambiguous richness of sound is both directional *and* encompassing that there is revealed a special kind of “shape.” This is what may be called an auditory “halo” or the *auditory aura*. The other, when speaking in sonorous speech, presents himself as “more” than something fixed, “more” than an outline-body, as a “presence” who is most strongly present when standing face to face. It is here that the auditory aura is most heightened.

The experience of an auditory aura is “like” the experience of music in which intentionality though keenly aware, “lets be” the musical presence so that the sound rushes over and through one. But it is not like music in that the temptation to become disembodied, to allow oneself to float away beyond the instrumentation is absent. Rather, in the face-to-face speaking the other is there, embodied, while exceeding his outline-body, but the other is in my focus as there before me face to face. It is in his speaking that he fills the space between us and by it I am auditorily immersed and penetrated as sound “physically” *invades* my own body.²

Moreover, the ambiguity of the auditory aura, most vivid when I am directly facing the other, is also part of the way in which hearing within the auditory field is structured. I listen for sounds with attention to direction. I sometimes find that there is a 180-degree error: I momentarily mistake the direction of a sound coming from in front of me to be one coming from the back, or vice versa. Ordinarily the mistake may be quickly corrected, usually by turning the head briefly and thus allowing the inadequate, momentary

perception to be adumbrated more adequately. But in the moment when I stand within the ambiguity of the fore-back direction, I also discover the possibility of the face-to-face aura presence that is a subtle existential possibility of the other as an auditory presence. For not only may the field be relatively “empty” on one side or the other, but there is a discernible difference between the listening which occurs face to face and that which comes from a side. Were we again to re-enter the construction of a purely reflective way of discovering the “shape” of our auditory perceptual opening to the world, this would provide one such clue for a reflective self-recognition.

The presence of the other embodied auditorily in the “excess” of the aura which not only “exceeds” the presence of the outline-body, but “fills” the space between us is yet another instance of the experience of the *invisible*. It is in the *voice* that the “excess” *is heard*, and a full sense of the presence of things and of others is one which calls for such listening.

The auditory aura is, of course, by no means restricted to the face-to-face speaking situation. It is present throughout the range of auditory experience, though not always so notably as in the face-to-face situation. Listening to music often may reveal the auditory aura as well, but it is best located by actions that disrupt the presumptive ideality of musical listening. The well-built auditorium “conceals” those auditory features that disrupt the immersion in the music. Nor is it accidental either auditorily or visually that the audience “faces” the orchestra, or that the better seats are those which are closer to the center. For when I listen to music I also *face* the orchestra, and the richness of its aura is such that while facing the orchestra the plenum of sound is full and penetrating. But, as noted above, when I begin to engage the movements of my body that I ordinarily use to locate directions and do so extremely enough, I can suddenly discover the echo from the back of the auditorium which vividly disrupts the previously full “halo” of the music.

To this point the auditory field has been surveyed with an ear to its spatial field significations. Within this field plenum of sound the range of variability from the rich and full filling of the field to the discernment of precise direction within the field reveals something of its “Parmenidean” features. Parmenides, as an ancient philosopher of presence, characterized Being as a “whole,” “without end,” “one,” “continuous,” and “homogenous or filled within the limits.” He characterized the limit thusly, “Being is complete on every side, like the mass of a well-rounded sphere.”³ A phenomenology of auditory field presence rediscovers these characteristics of experience.

But the spatial existential possibilities of sound do not exhaust its invariant features. Within the field plenum of sound there is also a “Parmenidean” *continuity*. So long as I experience, there is a perceptually

continuous sound presence. For although any one sound or even all sounds may be at the very edges of my consciousness, they are neither totally absent, nor can I escape sound. Throughout the day the ebb and flow of noise is continuous. If it is loud, as in the factory, the airport, or even the city, I escape to the quiet of the countryside and I notice the “silence”; but strictly speaking this is quiet, not silence. The rustling of the wind in the trees is quieter than the rush of the subway train, but it is a sounding. Even in the desert there is the wind and the crackling of the sun on the sand. And in the ultimate “escape” from noise in the anechoic chamber, I am suddenly startled by the noises of my own body, which lie masked in daily affairs. My breathing, the “whine” of my nervous system, and the inhibited flow of my bloodstream suddenly appear in the quiet as noise.

Continuity of presence is not restricted to auditory presence but is a field characteristic of all perceptual experience. I continue to “see” even when my eyes are closed, for, while I have closed out the things before me, my field does not become empty or disappear but merely turns dark (black or reddish). Fields as fields are constant presences that are never empty but filled as a plenum. Sound is continuously present to experience.

But this presence is also a *penetrating*, invading presence. Sound penetrates my awareness. As noise this penetrability may be shattering, ultimately even painful. The sudden scream at the moment of highest tension in the Hitchcock movie upsets my composure, and it is rightfully described as *piercing*. The sound of the siren coming from down the street sometimes makes me cover my ears to escape its intensity, but even then I only slightly muffle it. The rock concert in its musical orgiastic decibels takes me to the very threshold of painfulness at points. And in the Orwellian fantasies that now seem to be coming true, the police and political powers consider the development and use of high-intensity sounds to quell riots.

This existential possibility of sound has long been noted. The languages that relate hearing to the invading features of sound often consider the auditory presence as a type of “command.” Thus *hearing* and *obeying* are often united in root terms. The Latin *obaudire* is literally meant as *a listening “from below.”* It stands as a root source of the English *obey*.⁴ Sound in its commanding presence *in-vades* our experience, and although this invasion may be desirable, as in the cases of musical enchantment, it may also be detestable as in the unwanted noise of the jackhammer early in the morning. In both cases one’s train of thought is likely to be upset by the “command” of the sound which is so penetrating or loud that he can’t “hear” himself think. The ability to reveal interiors, as the essential penetrability of sound presence, even applies to myself as an embodied being. Sound physically penetrates my body and I literally “hear” with my body from bones to ears.⁵

If, noematically, sound penetrates, noetically there is also the problem of a response to this continuous invasion. In ordinary vision unwanted sights may be often simply closed out by shutting one's eyes. And although in the presence of intense lights, as in trying to sleep on a transatlantic flight in the presence of the movie screen, such simple measures do not suffice, a set of opaque sleep blindfolds is sufficient to close off the visual disturbance. But not only do our ears have no flaps to close off the sounds, sticking the fingers in them fails to solve the matter. Ultimately to escape unwanted noise we have to either actually remove ourselves from its vicinity or build a protective environment that shuts it out (the ordinary house is not sufficient protection to close out the sound of the jackhammer). This penetrability invades even the mute objects around us. This strength of sound is, of course, one of the factors which is also one of its weaknesses noted above. The penetration of interiors is precisely that possibility which exceeds the clear stopping at the surface which vision allows in some of its richer spatially distinct features. But the relative resistance of the thing does allow some sense of difference: there are auditory correlates to transparency, translucency, and opacity.

In terms of sound penetrability, however, the escape from or control of sound is essentially a matter of psychic control. I may even become habituated to loud sounds to the point that they do not count for the same disturbing invasions of myself which they at first show. The factory worker learns to tune out the machinery. And the youth-cultist seems even to thrive in the presence of noise.

The auditory field, continuous and full, penetrating in its presence, is also *lively*. Sounds "move" in the rhythms of auditory presence. Here we approach more closely that first listening that detects in sound an essential temporality. The fullness of auditory presence is one of an "animated" liveliness.

This existential possibility of sound ranges from the most abstractive to the most ordinary to the most extraordinary experiences involving sound, and it is often pointed out in the contrasts which occur in the absence of lively sound. Not only is Notre Dame without the choir empty, but it may suggest even a certain deathlike quality. In contrast, when sound is added to abstract figures, they "come alive." I go to a movie, and a short cartoon feature precedes the main show. It consists of black and red dots that already start to "come alive" when they begin to move across the green ground. But as they bounce off one another, jumbled noises mimicking speech are presented. Suddenly the moving dots in their lines and bumpings, in the presence of the "speech" and sounds of "yelling" become soccer players seen from above. The dots are animated by the sound that makes their motion anthropomorphically understandable.

Conversely, the sudden absence of sound can disembody a scene. In the movie *The Battle of Britain*, a technicolor reenactment of the air battles over England during World War II, at the height of the decisive battle Spitfires and Hurricanes dance in the air in combat with Messerschmitts and Junkers. Amid the loud chatter of the machine guns and the roar and sputter of the airplanes the sound track is suddenly and deliberately silenced. At the instant of the disappearance of animating sound, the scene becomes eerie, a moving tableau that becomes more abstract and distant. This momentary irreality of the disengagement of sound allows the battle to be seen as a strange dance without music. Emptiness which can be uncanny is silence in the auditory dimension.

The cinema films, those concrete exercises of phenomenological variations, provide endless examples of this same animating quality of sound.

In *2001: A Space Odyssey*, it was found that without the sound of background music the slow drifting of the spaceship did not appear even as movement. Also, the old favorite, the silent movie, is accompanied by the piano. The intimate relation between animation, motion, and sound lies at the threshold of the inner secret of auditory experience, the *timefulness* of sound. The auditory field is not a static field.

Here, then, we reach the completion of a first survey of the field-shape of sound. It is an omnidirectional "sphere" of sound that is variably full, rarified, or both in a ratio of relativity. This same ratio of relativity pertains to the copresence of the "shapes" of surroundability and directionality, manifestations of sound presences. The field of sound is also a penetrating presence that in certain instances unites and dissolves certain presumed "individualities" by its penetration in and through interiors in a power of penetration. This power of sound is also a dynamic and animated or lively quality of sound. And while all these existential possibilities of the auditory field are present in sound, dramatic and selected variables reveal these qualities in more striking form.

This page intentionally left blank.

Chapter 7

Timeful Sound

The tradition concerning the experience of sound is one that situates hearing as the temporal sense and the “world” of sound as one of flux and flow. The postponement of a consideration of this temporal movement of sound in order not to bypass the spatial significations of the auditory dimension must now give way to the examination of what appears first in the reflections on sound. Sound dances timefully within experience. Sound embodies the sense of time.

I listen to the presentations of sounds. The oliveback thrush issues his song which is punctuated by the less obvious crack of a twig in the forest. Both these sounds are accented by the interludes of quiet which are filled only with a breeze or the rustle of leaves. Each of these sounds comes into being and passes from being in a temporal dance which does not submit to my will.

At the first existential level, of course, these sounds are experienced as the sounds of things. The forest dweller does not confuse the beaver’s distinctive splash with that of the trout’s leap. There is not, at this level, a sheer sense of buzzing confusion or of structureless flux, unless the listener is exposed to a strange world not yet fully heard. For the flux and flow of auditory experience, upon a more concentrated listening, displays its own deeper rhythms and harmonies. The shapelessness of an initial flux and flow is due to the level of reflection, not to the existential possibilities of sound.

Here again we note that a phenomenological listening is also a learning that allows the phenomena to more and more clearly show themselves.

The deeper significations, not absent from first listening, do not “show” themselves fully in first listening. The level of reflective experience can easily be confused with what the phenomena show. For example, first investigations into perception may be noted to undergo definite stages of development. The observations of flux and flow during a first reflection on experience is not restricted to listening, although it is more dramatic in relation to each of the “senses” than it is for sight. But this is to be expected if sight is both a culturally preferred sense, and if its possibilities of experience are more thoroughly sedimented in a tradition of interpretation. It is harder for us to immediately relearn or regrasp the movement from ambiguity to polymorphous but structured wealth. It is hard for us to return to the “first seeing” of the blind man who also first sees colors that seem to fill the space of the room and “jump out at him” in a visual “flux and flow.”¹ Students, for instance, doing a beginning phenomenology of some perceptual dimension almost always are struck by the occurrences in the process. First, they note that there is often a lack of clearly experienced subject-object distinctions. In tactile experience to lie on one’s backside and to have to describe the experience calls for a noting of the indefiniteness and vagueness of where I end and the couch begins. But to leave the investigation here is to confuse an initial apodictic level with adequacy: the expert safecracker knows quite well how precise touch can be in his experience of tactile objects. Second, the beginner notes a certain struggle with language (which is also a struggle with experience), for he comes on phenomena which he has not previously noted and does not yet have or call to mind the words with which to describe such experiences. He is called on to provide a description of nuances which produces first metaphors or constructed terms before he can find the appropriate terminology. Third, as the reflective process continues, the beginning investigator begins to find that he gains a progressively finer sense of discrimination concerning the things which he experiences.

Such a progression is not unknown in ordinary experience even if not thematized as a reflective phenomenology. The beginning wine taster, after all, can tell little about the differences between the ninety-eight-cent fortified wine and the 1964 Medoc; in fact, for her, all wines taste alike, a statement that horrifies the accomplished wine taster who has forgotten her own early experience. The inability to discern the difference between a delicate sauce and plain gravy is characteristic of the quick-snack artist, not of the gourmet. Thus the question of temporality of sound cannot be left with the correct but superficial sense of the intimacy of temporality within sound.

To return to listening with an ear to the time and times of sound also calls for variations on more ordinary listening patterns. The first existential

level which attends to the sounds of things, particularly as the sounds of things primarily in the central focus of ordinary interest, needs adumbration into the larger gestalts of auditory temporality. There then appears a timeful march of daily sounds that may be spoken of initially in terms of the *rhythmic* temporal movements of sound.

This daily rhythmic quality to auditory presentation is an ordering of the first flux and flow that takes place within experience in terms of the background-foreground sounds in rhythm that are part of daily life. If I am in my summer home there is no mistaking the coming of the day in the chorus of birds. The night sounds of the porcupine and the owl are different but have their own regularity. In the city there is a rhythm, too, with the rush hours and daily rising crescendo of noises that at night recedes to pianissimo only toward the morning hours.

This music of daily sound may be described analogously as having the foreground and background textures of a melody with some form of bass accompaniment. In the woods the accompaniment is the constant babble of the brook and the sighing of the wind in the trees. In technological society that accompaniment is the almost constant, pervasive presence of a form of machine-produced hum. Within the self-enclosed buildings of contemporary architecture there is the whirl of the heating and air-conditioning machinery, the hum of the lighting, and the electronic whine of the technosphere that is the counterpart in that environment to the tides and the winds of the wild world.

These rhythm-section sounds are not effervescent or abrupt comings and goings of sound but an auditory texture and background that provides an auditory stability to the world. The lack of such a stable background, or a dramatic change in its rhythm, is the occasion for human anxiety. On the seashore the rhythmic splash of waves with the tide is both comforting and hypnotic, but the disruption of the hurricane or the sudden storm augers disquiet for the shore dweller. In Cambridge, Massachusetts, a number of years ago, a church installed a very advanced air conditioner. Yet the congregation continued to feel hot even though the temperature and humidity gauges indicated all was well. It was only after the engineer discovered that they couldn't hear the reassuring presence of the machinery that the problem was solved. An artificially produced fan noise soon made all feel comfortable, and the air conditioner was "felt" to be effective.

The temporal rhythms of daily sound are *structured* rhythms, and it is in rhythm that the background or field of auditory temporality is located. As a field background, rhythm is a *repetition* that is the index for auditory "sameness" or stability. The repetitions of the "same" morning cock crow, which gives way to the "same" sounds of the town clock or noon whistle,

fulfill the expectable temporal background pattern that allows humankind to take a certain stability for granted in ordinary circumstances. In this, rhythmic repetition plays a role functionally isomorphic with the stability of the ordinary visual background of immobility.

In ordinary visual experience the stability of the background against which the movements of objects may be seen remains the unthematized temporal resting or enduring of the visual world, but its temporality does not stand out. In ordinary auditory experience the equally taken-for-granted rhythms, familiar in their contextual expectability, provide the same stability function. Counterinstances where the background is disturbed further adumbrate the role of this function. When ordinary visual experience is disrupted by what are usually background features undergoing dramatic changes, a certain disorientation of ordinary experience may occur. For example, in a situation in which everything within the visual experience is set in motion or obscured from its usual ratio of foreground to background, the sense of "visualist" stable spatiality breaks down.

The first time a person goes to sea, if the seas are rough and the boat rolls, the whole ship can be seen in motion *even from the inside*. Or if one is inside an airplane that begins to bank, even with the windows closed one can see the plane turn from the inside. (Physically speaking this is, of course, not merely a visual experience. The inner ear as an organ of balance is implicated in this seeing.) If the day is light enough, the line of the horizon is often sufficient to reestablish some sense of reference for stability. But when even this is obliterated the usual sense of spatial relations begins to be modified.

I take my canoe into the harbor in a heavy fog and find there is no horizon. The fog blends indistinguishably with the water that surrounds my canoe. It is almost as if I were floating in a basin whose edges seem to curve upward. If I approach a buoy, it appears through the fog as if elevated higher in the air than it should be and returns to its expected position only when I approach closely enough for it, too, to become surrounded by water.

Auditorily the same disruptive change of background familiarity into foreground familiarity or an unexpected change of its rhythms produces a similar experience. So long as the constant whir of the fan or the electronic hum is relatively low in intensity, it remains barely noticed; but the continued presence of a single, loud, and intense sound quickly becomes disorienting. It even appears to waver and modulate in my hearing, and such a continuous sound is the auditory equivalent of the constant drip of Chinese water torture.

There is also a rhythm that lies hidden in the very stability of the mute object in vision that retains its motionlessness in a ratio to the motions that

I make with my eyes. If I stare at the rock, not allowing my eyes the rhythmic motion which glides over the surface of the object, the rock begins to “jump” or “waver” and ceases its normal stability; only here the ratio is inverted, for it is in the moving “grasp” of the gaze that stability is established.

There is in both visual and auditory experience a dialectic of motion to stability that undergoes various forms of relatedness. If sound is always in “motion” this motion itself in the regularities of rhythm functions as a stability. If the stable visual object is fixed by the unattended-to motion of my own eyes, this too is a ratio of movement to stability. But in each case the stability function, in ordinary affairs, takes place as the implicit and presupposed background against which the foreground themes of life take shape. Temporality is neither simple flux nor enduring stability alone.

In the discussion of the rhythms of daily life, particularly in regard to the intimacy of temporality in sound, there is a preceding analysis which has already paved the way for further variations on sound in time. Husserl’s development of a phenomenology of inner time consciousness has already opened the way for some investigation into the auditory dimension. Here, however, that analysis will be remodeled in terms of the language of focus, field, horizon, and so on.

A phenomenology of experienced temporality soon comes on the notion of a *temporal span* or duration of sounding that is experienced in listening. I do not hear one instant followed by another; I hear an enduring gestalt within which the modulations of the melody, the speech, the noises present themselves. The instant as an atom of time is an abstraction which is related to the illusion of a thing in itself. In terms of a perceptual field we have noted that a thing always occurs as situated within a larger unity of a field; so temporally the use of *instant* here is perceived to occur only within the larger duration of a temporal span, a living present.

Moreover, according to Husserl’s prior analysis (to be modified below), this temporal span displays itself as structured according to the onset of features coming into perception, *protension*, and the phasing and passing off of features fading out of presence, *retention*. Within the temporal span the continuing experience of a gestalt is experienced as a succession within the span of duration. Thus the passing automobile whose auditory “Doppler effect” of changing pitch presents itself as a unity within the temporal span. Or when I listen to someone speak, I do not ordinarily hear a syllable at a time, or even a word, but I hear the larger melody and flow of speech as an ongoing rhythmic unity.

But by an act of deliberate concentration I find that I can so concentrate to get a syllable or a word.² It is, however, important to examine this attentional aspect of auditory intentionality. When I do so concentrate,

seeking out a certain syllable for example, what happens in the experience is that the ordinary flow of speech becomes background and may not be grasped significantly at all. Or if it is grasped, it may have to be reconstructed in experience, as when one listens only vaguely to what someone else is saying. In such experiences lies the phenomenon of attentional intentionality that may be termed here *a temporal focus*.

In approximate terms, temporal focus operates similarly to all the focal phenomena previously noted. First, it is a focus *within* a larger unity, a field. In this case the field is the temporal span of lived-through time. As such the focus is attentional and selective in its operation so that the ratio of a foreground to background effect obtains. In the examples noted above a “narrow” instance of auditory focal attention is one that attends to single syllables such that the ordinary flow of speech becomes background. Here effects similar to those noted earlier may also be noted: the “narrower” the focus, the more the background recedes into a fringe appearance. Thus in a highly concentrated “narrow” focus I get certain sounds in the other’s speech but may find it almost impossible to note what was said; and contrarily in a “broader” focus, as in attending to what is being said, I may miss or barely be aware of the aspirated *s* that is characteristic of the other’s speaking style.

Here, too, the relation of *instant* to duration may be located within the experienced temporal span. In a narrow focus I auditorily grasp an instant (as foreground) within the ongoing span (as background). And in this sense there remains the variability of focal acts previously noted. The attentional focus may be narrow, fine, or broad. If now the possibilities which occur in a broadened focus are examined, there appears yet another similarity with the first approximation within focal—field presences. A maximally broadened focus is “panoramic,” as for example in the case of listening to a piece of music in a relaxed mood (not listening critically to seek particular instruments or notes or themes).

Within auditory experience all these possibilities of auditory focus are temporally located as temporal focal acts also. But to this point only the *attentional* aspect of the temporal focus has been noted. There is also a question of the *shape* or temporal directionality of the temporal focus. Here it is important to note that a phenomenological investigation of temporal structures is such that a “linear” metaphor concerning the auditory-temporal field would be quite misleading. “Linearity” is a reduction of the complexity of temporal duration and *depth*. Within auditory temporality the temporal span shows itself as containing a multiplicity of auditory events that are intentionally graded. There is both a simultaneity and a succession: Eric arrives with the clink of the milk bottles that mix with the sounds of Lisa drying dishes in the kitchen. All the while the cement mixer continues its

put-put sound even though it is Saturday. Within this plethora of sounds the attentional selectivity of auditory intentionality continues. I auditorily scan the multiplicity varying my attention in terms of the sounds that catch my attention or in terms of those I seek out. I may narrow or broaden this attentional aspect of auditory focus at will.

But this general feature of auditory intentionality does not yet reveal the *shape* of a temporal focus as such. If now I raise the approximate question in relation to one shape of focal perception, the question of this feature becomes clearer. In visual perception the shape of focal attention found its locus in a central core within the visual field. Certainly this focal core is variable (within limits) and in field states may be even panoramically expanded to approximate the “attending” to a field as a whole (again within limits). However, although this broadened shape occurs it must be noted that a ratio of explicit and distinct to inclusive but less distinct remains. In the field states of boredom or enthrallment while viewing panoramically I do not have a *detailed* attention, for as soon as I begin to seek out details, centered focal attention may again be reflectively noted. Thus the gravitational shape of a visual focus is weighted in the center of the visual field as a phenomenological structure.

If now, “analogously,” the seemingly odd question of a shape is raised in terms of temporal focusing, the question is whether such a focus is similarly bound to the “center” of a temporal span, to a now-point, or whether it displays a different set of possibilities. Is temporal focus centered toward the middle of the temporal span or does it, particularly in a closer “analogy” to the spatial shape of auditory focusing, display the possibility of movement throughout the temporal span?

Such questions at first seem unusual or even odd, yet their point soon becomes apparent in the experiences of listening that concentrate on temporal features of the auditory field. Husserl has already characterized the temporal field as one which presents itself in terms of what are here field-like characteristics bounded by horizons. The “now” is futurally funneled by a set of expectative *protentions*; these expectations belong to our temporal experience. Protentions are the temporal “empty intentions” that “search” the coming into presence such that they may be fulfilled or frustrated. Protentions are the attentional structurings that may be futurally oriented.³ However, it is also the case that Husserl did not deal primarily with futurally oriented protentions, and in fact his analysis of time consciousness was almost exclusively oriented toward the movement into the sense of the past. The field of time, however, is shown to contain a great deal of complexity. The coming-into-being of a perceptually temporal experience is spoken of as a “welling up” with a “leading edge” that Husserl

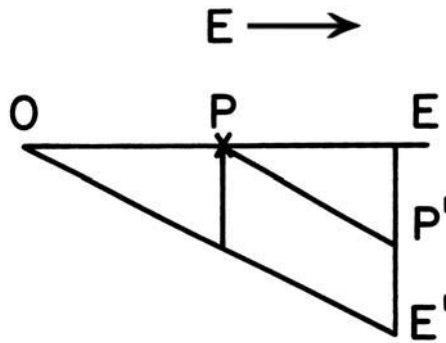

FIGURE 7.1 Husserl's Time Diagram

often characterized as a *source point*.⁴ The other extreme of the field is a “running off” of phenomena in *retentions* that are sometimes characterized as *reverberations* or *echoes* that “sink” into the just-past. At their extreme point there is a horizon that transforms primary retention into genuine recollection that is the first genuine appearance of memory. Husserl’s own primary concern with the phenomena of “running off” and sinking back into the past in contrast to the equal concern with a futural concern may be evidenced in a modification of the diagrams that he uses for time consciousness (fig. 7.1).⁵

I have combined two Husserlian diagrams in figure 7.1. For Husserl, OE is the series of now-points, the temporal span in this context; OE' is the “depth” of the span that contains within it the reverberations and sinking back phenomena of those points that “trail off” in retention until they “disappear.” They reach the *horizon* of the past, and when this occurs they may be returned under a *recollection* that is noematically and noetically differentiated from the “trailing off” of what occurs within the present temporal span. For Husserl the “direction” of time is from the future toward the past as represented in the directional arrow above the diagram. Husserl is, of course, quite aware that there is also a horizon of the future from which the original onset of what appears within time consciousness presents itself as a source-point. It is further the case that Husserl himself opens the way toward the modification which is introduced below, in that *within the temporal span* it is possible to narrowly focus on *either* the source-point or the onset of an event (here a sound, as is often used by Husserl) or on the phenomenon of “running off” or “trailing off.” It is this capacity of temporal focus that points to certain important and characteristic aspects of the shape of temporal focal-field-horizon structures.

Prior to the modification, two simple variations that experientially establish this variability of temporal focus need be noted. If I am to be the subject of a psychological experiment in which a click is to be the signal of some action, I listen intently for that short and barely enduring sound. My protending expectation “searches” the futural “edge” of the temporal span in order to be prepared for the onset of the click. I have “pushed” all other auditory-temporal factors into the background and listen only for the click. As soon as the click presents itself at the futural “edge” of the temporal span, I no longer attend to it but as quickly as possible pass on to the act it signals. In this I specifically do not attend to its “running off” reverberation.

Conversely, I am now to listen to a tone to identify its position in the musical scale. Again I listen intently with the same selectivity for the tone. This time at its presence I do not attend specifically to its instantaneous source-point but pay special attention to its tonal quality which appears even more strongly in its “running off” reverberation, and I identify it as middle C. In these two variations I “aim” my focal attention to different aspects of the event in a variation of focus. This capacity is of extreme importance to our acquaintance with auditory phenomena.

The first modification to a merely ordinary focus, then, is one which must take account of focal shifts within the enduring temporal span. Were Husserl’s diagram to be used, two essential possibilities of temporal focus could be located thusly (fig. 7.2):

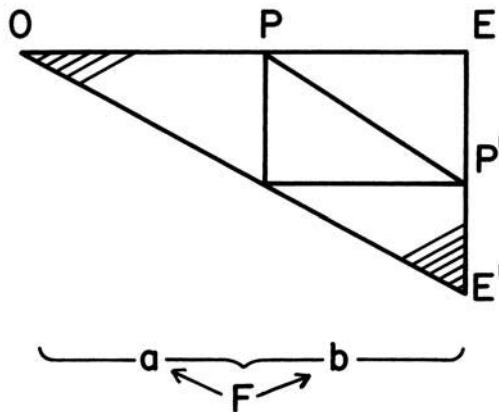

FIGURE 7.2 Temporal Focus

Where F is the (noetic) act of focus its aim may be either at the “leading edge” of the temporal span directed toward the onset of the source-point of

the auditory event (a), or directed toward its reverberation as the “trailing off” of the sound presented (b). Here once again we have a relative variability to the focal act. Furthermore, the variability displays the same ratio of focal-to-fringe inversions as all other acts of focus. If I attend to the reverberation or “running off” of the sound, this in no way obliterates the coming into presence of the continua of auditory events, but it does allow them to become *relatively* fringe-like. Inversely, when I attend to the onset of each source-point, say a new note in the musical phrase, the reverberation in “running off” does not disappear but is relatively fringe in ratio to the focal attention. Finally, it should be pointed out that there is a sense in which this variability in each of these variations is already a highly concentrated and “narrowed” focus in contrast to the more ordinary listening in which one is usually engaged. But in this case the “place” of the narrowness within the temporal span is located either at the oncoming source-point or at the trailing-off reverberation. A third possibility is, of course, a broad focus that extends throughout the temporal span. In listening to music, for example, one usually allows the full richness of the musical presence to occur in what is here a *broad* or *open* focus with the onset of each note enriched by the depth of those that have just preceded it “equally” present.

There is, moreover, a certain peculiar “privilege” for certain types of phenomena in the location of such features of temporality. If I return to the variations on the mute, stationary object in contrast to various types of “moving” phenomena, I now more precisely locate one of the sources of the characterization of time as a type of “motion.” If I look at the calendar on the wall, it stands out as motionless and mute, and in relation to it I detect only a massive *nowness*. Its appearance neither dramatically *comes into presence* nor *passes from it* in its motionless state. If I want to take note of its “temporality” I must already make a reflective turn to *noetic* phenomena: it is *my consciousness* that is *aware* of the *passing of time* before this object. However, if the object is moving my son’s baseball suddenly looms before me, and I must either catch it or avoid it before being hit—in the duration of the event of the ball coming toward me the moving ball allows a shift toward the *noematic* appearance of successive time. But even more dramatically, when I listen to auditory events there seems to be no way in which I can escape the sense of a “coming into being” and a “passing from being” in the modulated motions of sound. Here temporality is not a matter of “subjectivity” but a matter of the way the phenomenon presents itself. I cannot “fix” the note nor make it “come to stand” before me, and there is an *objectivelike* recalcitrance to its “motion.” Conversely, when those rare occasions arise on which one is purposefully placed in the presence of a single, sounding tone which does not vary and in which the depth of foreground to background features is eliminated, this

presence can not only be deeply disturbing, but it begins to approximate the solid “nowness” of the stable visual object and time sensing “returns” to its location “in oneself.” The intimacy of sound and time appears as an existential possibility of sound that reveals its range of forms.

Focus, however, is to be located *within a* field which in turn is bounded by horizon if the initial model may be discerned in relation to temporal as well as spatial features. The question of a field poses immense problems in relation to the experience of temporality, and there is a sense in which within the limits of this study important dimensions of the temporal field must lie outside of consideration. But one modification on the Husserlian notion of time consciousness is called for here. It is one which more equally notes the protensive futural time intention.

In figure 7.3 the span from (a) to (b) is the durational span of present time awareness. It “trails off” in retentions until the horizon is reached, at whose “edge” retention changes into recollection that can also be presented but in a different noematic modality. The *field duration* is the totality of what is or may be “within” temporal awareness (c). The horizons of the “future” as the area of the not-yet relate to protended expectations which display themselves in various types of imaginative projections (plans, daydreams, specific expectations, predictions) which, while located within a present awareness, emptily intend “toward an absent horizon.” Likewise, that which is no longer presentable in its perceptual retentive fulfillment, such as those types of recollections and other constituted past intentions of “history,” points toward the “other” limit of time consciousness, the horizon of the past. The interest here, in which the experience of auditory phenomena with regard to its temporal presencing, concerns only the structure

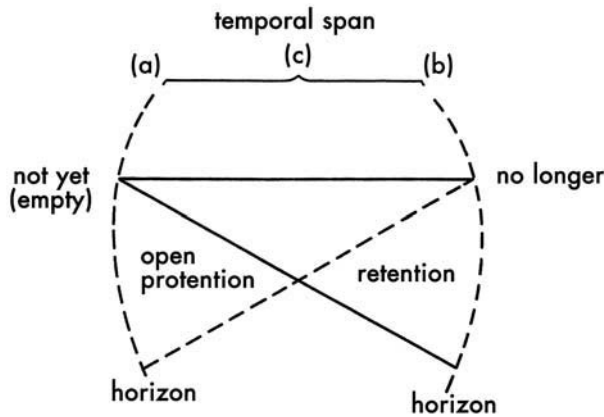

FIGURE 7.3 Temporal Span

of the span of temporal awareness. And although this has been designated the span of field duration, it can be seen from the previous variations that there is a sense in which within field duration the focal act can be concentrated either at the limits of the protending horizon of field duration or at the limits of the retentional horizon, or it may “span” the entire durational presence. Within the limits of field presence, focal concentration is not limited to a “center.”

In passing it may be worth noting that the modifications proposed retain the “borrowed clarity” of the visual-spatial language that remains so much a part of the philosophical tradition and equally a part of a Husserlian-style set of approximations. It might be thought that a shift toward a more musical set of terms would be helpful, but an examination of these terms often reveals precisely the same type of cross-sorting in terms of visual-spatial metaphors. One speaks of one note being *higher* or *lower* than another; music may be *bright* or *light*; there is also *a distance* between notes, and so forth. There is an *intensity* of sound, but intensity is also a term regarding light. This borrowing of extant approximations, however, has its advantage in its silent use of clear conceptuality that is sedimented in visualism.

However, now that both the attentional and directionally shaped aspects of temporal focus have been preliminarily noted, it is possible to return to the functions of this variability of temporal focus within auditory experience. It is now possible to retrace the range of spatial features and indicate the role that temporal focal (noetic) acts play in the constitution of spatial significances. In performing this descriptive analysis it appears that in regard to temporal factors a shift has occurred in the order of procedure. This is a shift from noting noematic to noting noetic correlates. But this shift is partly deceptive in that it allows tentatively some of the traditional prejudices concerning time to remain extant. If time appears as “more subjective” in temporality, that is due partially to the traditions that continue to value stability over nonstability. Here, however, stability and changeability should be essentially interrelated as they are within the limits of a Husserlian-style first phenomenology.

Temporal intentionality is deeply implicated in every spatial signification of the auditory dimension. In a most preliminary and general way this may be noted in the manner in which a certain temporal duration gradually renders these significations clearer from the “weakest” to the “stronger” spatial significations. In the presentation of edge-shapes, for example, the auditory presentation is clearly dependent for its degree of clarity of shape upon more than an instantaneous presentation. The marble which rolls in the box presents its edge-shape only if its roll endures long enough. If the marble were to be dropped on the floor and then caught on its first bounce,

the auditory result would not be adequate for even the slightest discernment of an edge-shape other than that of a point of contact. And, in this “weakest” aspect of auditory spatial awareness, the longer the duration (within limits) the more “precise” the edge-shape phenomenon.

The same is the case with the detection of surface characteristics. But here the question of how the thing is given its voice is also important. In the instance of a *contact voice* that results when one object strikes another, it has already been noted that the surface “area” that is revealed is very circumscribed. Repetition and duration are also implicated here. The footsteps in the hallway as they *repeat* themselves in a pattern of approaching nearer while also sounding on the tile through the *duration* of the repetition presents at least a series of circumscribed surface aspects. The auditory surface, in this example, does not “spread itself out” in a wholistic gestalt of entire surface but presents itself as a series of surface-aspects. This can, of course, be modified by, say, sliding an umbrella handle across the tiles so that it clicks in each crack between them. But again the surface in this case approximates an edge-shape and does not spread itself out. In all these variations the repetition and duration of the temporal dimension presents itself as “making possible” the “weak” spatial discrimination that sounds present.

A somewhat different aspect of surface is presented if the giving of voice is that of the *echo voice*. Here the distance of the surface reflecting the echo voice may be discerned within limits, and perhaps even a quite vague recognition of an internal shape is revealed as in the case of echoes in an auditorium. But the surface is presented vaguely as present and perhaps as relatively hard or less hard (concrete versus plywood walls), at least within the limits of human hearing ranges as contrasted with the more precise hearing ranges of animals. Again repetitions and durations are deeply implicated in the clarifying of such surface presences. The repeated clicks of the blind man’s cane or of a constructed echo-directional sounder almost seem to temporally build up the gradually clearer sense of surface presence. With sound the subtle time dimension “allows” the gradually clearing spatial significances to be known.

Each of the above phenomena have been located phenomenologically. Although strictly outside the bounds of a direct phenomenology that attends to experience as it presents itself, there is also an indirect sense in which the sciences also “know” the temporal dimension in auditory spatiality. Given an interpretation of science as constituted by an instrumental context in which instruments extend and embody experience, the detection of microtime elements in the auditory discernment of spatial significations may also be shown. The physical understanding of sound belongs to the study of wave phenomena. Location, primarily the ability of a human listener to detect the

direction of a sound source (within the limits prescribed by the experiment), may be shown to depend on the microseconds of difference in which a given sound wave reaches first one ear and then the other. The experimenter can easily change the subject's sense of direction by varying the time elements involved, making the sound appear first on one side and then on the other side of the head or even "marching" the sound from one side to the other. However, "metaphysically," such studies present a far too complicated set of necessary reinterpretations to make them easily or readily available for a direct phenomenology. What can be tentatively accepted as an *index* for a phenomenological investigation is that by making temporal factors of the microlevel available through an instrumental context, the phenomenological uncovering of the temporal dimension of auditory experience is extended confirmedly to that microlevel.

The same degree of precision or minute analysis is called for phenomenologically. Here, in addition to the more obvious roles of repetition and duration in the temporal constitution of spatial significances, there is an important role that is made possible by the noetic operation of temporal focusing.

The phenomenon of *reverberation* as a phenomenon of auditory temporal "running off" is of particular importance as a first instance of discriminating how temporal focus is employed noetically.

It is in relation to the various types of auditory discernments of *interiors* that the temporal auditory reverberation phenomenon is most apparent. I strike a brass goblet. In its ringing reverberation I hear the resonant metallic "nature" of the object as the sounding presence of its interior. However, if I pay very close attention to the presentation of this auditory event it soon becomes clear that on analysis not every "part" of the event is of equal importance. If I abstractly deconstruct this event as (1) the instant of the striking of the brass goblet (with my fingernail), followed by (2) its ringing reverberation *after* my finger has moved away, then it is clearly not the first tap to which I attend but to the ringing reverberation in the detecting of the interior.

There are perceptual "reasons" for this. First, in the instant of the tap there is the instant occurrence of the two "voices," the duet of things. There is the click of my fingernail on the goblet *and* the beginning of the sounding of the goblet. And in the selectivity of auditory focusing I can focus on either one or the other; but in both cases a precise examination of the noetic act shows that the focus is on the auditory temporal *reverberation* that follows and "runs off" the instant of the tap. The dull and almost instantaneous "failure" of reverberation of my fingernail is also revelatory of the difference of its interior "nature" contrasted to the continuance of the ringing brass. and were the instant of the tap on the brass somehow instantly damped, I

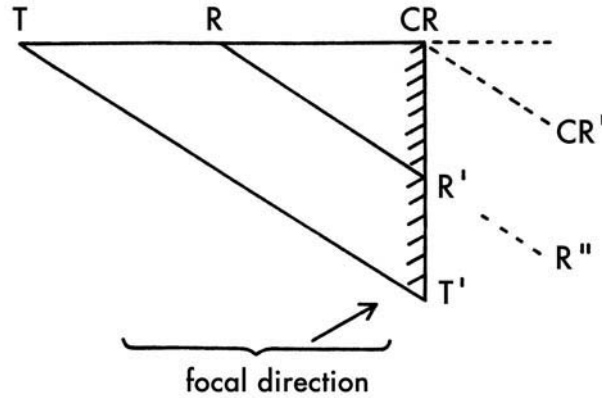

FIGURE 7.4 Focal Direction

would either fail to discern the interior or be seriously misled into believing that the brass goblet was something else. The instant of the tap reveals little, but the reverberation reveals a great deal. This obtains in noting that the reverberation of wood is as distinctly different from that of brass as is the distinctive sound of china or crystal from that of lead or plastic.

Thus if the “aim” of the auditory temporal focus is diagrammed according to the Husserlian model, figure 7.4 would be the result. T is the instant of the tap, which is distinguishable from R, which is the succeeding reverberation. T also “trails off,” however briefly, in T', but it is not specifically attended to in the context of a question over interiors. R, which both continues as CR and “trails off” as R', is attended to in the act of a “fine focus” of auditory temporality.

This same following focus on reverberational phenomena occurs in relation to interiors if the “voice” that is given is that of the *echo*. If I am practicing a human adaptation of “echolocation,” as in the use of a tapping cane, or if I am blind and using this method to navigate, again I do not attend to the instant of the tap. Indeed, I do not pay much attention to the tap at all unless I am more interested in *a surface* than in the wider sense of distance and the presence of reflecting surfaces. Thus I listen for the echo, I “follow” the echo, which gives me whatever sense of vague walls or corridors within which I must move. Again the “fine focus” is on the “following” and “running off” phenomena of the whole temporal event.

Finally, the same focus on reverberational phenomena occurs in relation to the auditory sense of distance when the question involves a giving of “voice” to things. If I call into a well, it is to the echo and its reverberation and its temporal “running off” to which I attend. It is important here

that not only does the involvement of temporality in auditory experience show itself essential at every level and in the most subtle ways, but noetically there are extremely fine discriminations that point up the ultimate concrete space-time of the world.

If reverberational phenomena show themselves as important to the auditorily admittedly “weak” discriminations of shapes and surfaces and also as important to the somewhat “stronger” auditory discriminations of interiors, the noetic constitution of auditory directionality shows a different possibility of “finely focused” auditory intentionality.

I listen to the jet airplane coming into Heathrow Airport in the landing path that lies over my house. I listen with an ear to its direction. Even when closing my eyes I can “locate” it, although I note, as previously, that when I am precise and careful its auditory presence compared to its visual presence yields a slight syncopation of appearances that bespeaks a certain “accuracy” to direction if not to “location” at the distances involved. But in this instance I note that the auditory presence of the jet is a “complex” one in that “accompanying” the jet are many echoes that reverberate from the various buildings around.

I begin to perform the variations on the many aspects of the auditory presence of the jet that show the phenomenon more fully. I quickly note that if I so desire I can focus on the echoes that reverberate around, but the moment I do so the first clear sense of directionality in relation to the airplane recedes and becomes confused. Only when I return my focal attention to the “leading edge” of the auditory presence of the jet does the clarity of its directional location return. Contrarily, when I return to the echoes which proceed from the jet the sense of directionality becomes diminished, but I do get the usual vague senses of distant surfaces. Here the jet has become the sound source for an echolocation. But this variation begins to show that the directional location is constituted by a specific focal act that concentrates on that utmost “leading edge” of the sound appearance. Were this example to be made strictly analogous to the previous ones dealing with shapes and surfaces, it would be to the instant of the tap that I would now attend. I auditorily seek the instant of onset (which continues) and not the “running off” that follows.

I have already noted that clicks reveal locations and directions more precisely than continuous tones. Whatever the physics of such a difference may be, here is also located a noetically discernible difference in the constitution of direction. The repeated click gives a “sharper edge” precisely to the onset of the instant than does the tone. The strictly continuous tone, particularly if electronically “pure,” is “like” the stable object that “hides” its temporality and obscures its “welling up” into time awareness.

A further variation that helps locate the noetic focus at the “leading edge” of the sound event when discerning direction is the complication that occurs when the source of the sound is “shadowed.” If I am listening to the sound of the jet, so long as it is overhead I can focus on its directional presence. But when it passes over and to the other side of my house, it becomes more difficult to locate the direction and, conversely, the echo phenomena from the other buildings become more intrusive. In this instance I am positioned in an *auditory shadow*, and, as in the case of visual objects, the directionality of the sound is obscured (although not obliterated) by the intrusive object that changes the directional presence. Even in relation to my body this auditory shadow is slightly detectable. If at first I cannot get the desired preciseness of direction, I may turn my head slowly from side to side, and in the process of casting this auditory “glance” over the sounding I get the desired greater sharpness. But if I pay close attention to the sound, I may also note that the sound on the “near” side is “stronger” and “more intense” than on the other side.

These variations indicate some of the roles that temporal focusing plays in the constitution of spatial significations in hearing. It is important to note that it is by a different noetic focus that different noematic aspects manifest themselves. Thus the discernment of shapes, surfaces, and interiors, all of which are revealed through the focus on reverberational and retentive “edges” of the temporal span, are constituted quite differently than is the case of directionality which is made precise through the noetic concentration on the “welling up” of continuous source points or the leading “edge” of an auditory temporal occurrence.

The third possibility of temporal focus also may be taken into consideration. In the experience of music, presuming a normal and interested attention, the “filling” of space has been noted as the auditory noematic presence of music. This “filling” at peak moments surrounds, penetrates and often obviates the ordinary sense of “inner-outer” in the musical gestalt. But this noematic presence is also correlated with the type of noetic act which does the attending. In listening to music I do not primarily attend to “things,” for music provides the temptation to move away from things. Nor am I ordinarily addressing myself to practical questions concerning spaces, shapes, or even directions; and, indeed, in the presence of full orchestral sounds the problem here is one of too much rather than too little sound for such distinctions to appear clearly.

When I turn to the noetic act what shows itself reflectively in the case of this type of listening to music is that the act is not focused on either the “leading edge” or the “trailing edge” of the reverberations of the music but is an “open” attention. Noetically the act of listening to music “spans” the

full temporal duration in an “active” “letting be” of the musical presence. My protending expectations are keenly open to the oncoming “flow” of the music, and my retentional awareness is filled with the reverberations that make the music rich. Auditory focus here is “expanded” and broad (though intense). In music there is the possibility of a *field state*. This is the listening that is analogous to the visual taking in of an entire vista. It is “full” both spatially and temporally.

In the case of musical listening the “full” noematic presence of the music is correlated with the “open” noetic listening act. And at its peak occurrences in which the music “washes over and through” one in its full presence there is met the possibility of the field state in which focal attention “stretches” to the very boundaries of sound as present. This “stretching” and “openness” is again fully *spatial-temporal*. But this spatiality is also “thick” in that I cannot find its limits. Although I may be “immersed” in this “sphere” of sound, I cannot find its boundaries spatially. The spatial signification of a horizon is obscure. How “far” does sound extend, given some recognition of relative distance? Where is its threshold, even if I can follow a sound until it disappears? And although sounds may come from any direction how far do they “extend”? I find no clear sense of horizontal boundary such as that of the “roundness” of the visual field.

But even in the paradigmatic case of music, in spite of the tradition that music is a kind of “pure presence,” I do find a sense of horizon as boundary. The musical presence does *not* extend indefinitely, although a horizon precisely in its “location” at the farthest extreme from ordinary focal attention remains difficult to discern. But in the case of listening with both its “forward” and “pastward” focal possibilities, and particularly with the “open” possibility instanced in musical listening, a sense of an auditory horizon *as a temporal boundary* does begin to show itself.

The sounds which “well up,” which “suddenly appear,” seem to come *from nowhere*. They present themselves continuously as having a “temporal edge” and as “trailing off” into the equal *nowhere* or nothingness of the no-longer present. It is here that we reach a clearer sense of limit characterized as a horizon, but in the case of the auditory field that horizon appears most strikingly as *temporal*. *Sound reveals time*.

Chapter 8

Auditory Horizons

With the phenomenon of the horizon as limit simultaneously are reached the limits of phenomenology as a philosophy of experiential presence, of phenomenology under the sign of Husserl as a first phenomenology, and of the initiation of a movement to second phenomenology under the sign of Heidegger. It is also the moment when the most extreme temptation occurs to lapse into a type of “metaphysics” that would be an attempt to get beyond presentational experience by means of an “explanatory” strategy. Such a leap from description to “explanation” is the place of Democritean doubt that sense warns will be the downfall of thought.

But at the juncture where a second phenomenology begins to emerge, the strategy remains *radically descriptive*. This is the phenomenology that operates under the guidance of Heidegger and, in particular, the “later” Heidegger. It is Heidegger who has among contemporary philosophers of the phenomenological tradition most radically posed the question of a thinking that is an alternative to not merely Cartesianism but to the whole metaphysical tradition. And it has also been a hallmark of the later Heidegger to be concerned with the question of the *horizon*.

But it has also been the fate of a second phenomenology under the sign of Heidegger to be radically misunderstood, precisely because of its nearness to the poetic, its radical alterity to metaphysics, and its at first seemingly strained “descriptions” which, from the entrenched and assumed positions of a dominant metaphysics, have prevented that phenomenology from being

seen as the careful *description* it is. The reading of second phenomenology entered here is one that accords to the language of a Heideggerian phenomenology its proper due as *a description of horizontal phenomena*. In the form of a Heideggerian “epoché” that “lets be” that which shows itself, it is “the things themselves” that call for the descriptions characteristic of this phenomenology of limits. A second phenomenology pushes a philosophy of presence to its final limits in the question of “absence,” but it does this without reverting to the hypothesized forms of nonpresent presence utilized in all metaphysics.

There is a leap made by metaphysics. When the limits of sense are reached, it posits an unsensed sense; when the limits of consciousness are reached, it posits an unconscious-consciousness; when the chain of causes threatens to proceed to infinity, it posits an uncaused-cause. And in this leap that has had such a varied history in Western philosophy as the posit becomes “mind,” “matter,” “the Absolute,” “the unconscious,” and so forth; *reality* is thought of as *other than* what is found in experience. The result is that experience invariably becomes either mere subjectivity or an epiphenomenon. Symptomatically it is the appearance of horizons that occasions this first word of metaphysics.

Phenomenology, even in its Husserlian form, begins contrarily in a “step backward” to the roots of metaphysical origins and the origins of philosophy itself. By reviving in the most rigorous manner the science of the description of presence, Husserl placed himself at the origins of Western thought, although this did not become fully evident even to Husserl until his later writings, particularly the *Crisis*. It is there that he discovers the retrograde movement into the teleology of Western thought, going back from Descartes to Galileo, and back from Galileo to the very “invention” of the theoretical attitude in Plato. In this sense Husserl began too late in his career to open the full implications of a hermeneutic and demythologizing deconstruction of metaphysics.

But Heidegger, already having learned the lessons of first phenomenology made possible by Husserl, from the very beginning gave a historical-temporal dimension to his own version of *epoché*, which becomes the deconstruction of *epochal* constitution. In *Being and Time* that historical dimension of *epoché* is the call for a “destruction of the history of ontology.” And in spite of the fact that the last parts of *Being and Time* were not completed as a specific extension of that project, the deconstruction has continued to take place more and more radically in the work and thought of the “later” Heidegger.

In this context, however, what emerges in this deeper probing into the constitution of Western philosophy and thinking is the question of *horizons*.

More specifically the horizon as “spatial” appears in Heidegger’s *Discourse on Thinking* as “that which regions” (*Gegnet*), and in “Time and Being,” a lecture whose title reveals that the original program has not been given up, the “temporal” dimension of horizon is recognized as “Event” (*Ereignis*).¹ The matter here, though, is not a matter of interpreting Heidegger but of a certain recognition of the appropriateness of the phenomenological language of the later Heidegger precisely for the description of horizontal characteristics. For the task is to describe horizons without falling into the temptation of “metaphysics” in positing an unexperienced stratum of “experience.” Second phenomenology begins with the question of the horizon as limit.

The transition to a second phenomenology is not abrupt but continuous if correctly understood. The continuity of the transition may be shown in the way the question of horizon “borders” on the previously central concerns of focal and field phenomena. The horizon as limit is an expanded ratio from the “center” of focal concerns.

This transition can be recalled from the very first appearance of horizons as limits after the first visualist model. Within the limits of presentational experience through the visual field there was a movement that began with the ordinary modes of focal or central vision toward the often implicit background and field phenomena. It should now be noted that, corresponding to ordinary focal attention and then to the question of taking note of the field as field, there is also a shift in attention and in the way in which the phenomenon is experienced (noetic correlation). The field, in turn, was seen to have a spread or expanse that eventuated in a barely noticed, vague, but nonetheless discernible border or limit. This was the first meaning of the horizon in terms of the first approximation.

From this beginning, however, a certain difficulty was also preliminarily mentioned. The “observation” of the horizon as limit is an extreme type of “observation.” It is an “observation” that stands at the extreme limits of observation itself. Thus if focal attention is central and field attention is ordinarily a fringe awareness, then horizontal awareness is yet more removed from the center. Moreover, one *cannot* move the horizon into the center, and, if noted at all, the horizon is noted “from the edges” almost indirectly. Its significations are enticed only by the barely perceived motions and experiences that begin to elicit its withdrawing presence. Yet, with a certain type of questioning it becomes possible to note that it has an indefinite but roundish shape; its “edge” as limit continues to escape (direct) attention as it recedes. I fail to fix it as it shades off into the imperceptible. And I speak correctly in saying that beyond this limit is a region of the invisible, because whatever becomes visible does so only within the field of vision and must be given to that field. Outside the field lies *nothing* visible.

Within this movement and transition from core vision toward the first meaning of horizon as limit there was seen to be a set of relative relations between focal and fringe phenomena, a ratio of central to peripheral possibilities that were ordinarily structured according to a foreground and background arrangement. At the same time the essential situation of all foreground phenomena against or within a field was also noted.

Now, however, the notion of a ratio may be extended to a second level. There is a second ratio which is more expansive than the focus-fringe ratio, and it may be termed *the field-horizon ratio*. In the form of general structuring this larger ratio displays the same general features as the focus-fringe ratio. Only now we may speak of the horizon as situating the field. Roughly, *the horizon situates the field which in turn situates the thing*. This *double ratio* may be illustrated similarly to the first visualist model (fig. 8.1).

Here the first focus-fringe ratio is R' , the constant relativity between focus and field in which focal objects are situated within their field. But the field itself is also situated in a constant relative ratio, R'' , which is that of field (including, of course, its focal center) to the horizon that shades off into the region of invisibility that is *absent* in contrast to presence. But what *can* be described is that bordering, that shading off, that disappearing that does occur at the horizontal limit and the relation which that obtains between absence and presence. This is a demanding task for a descriptive philosophy of experience.

There is then a certain continuity between focus-field and horizontal characteristics in a graded ratio of extremity. If ordinary experience is normally so focally concerned that it even “forgets” the implicit field that situates the central phenomenon, so even more is the horizon as limit likely

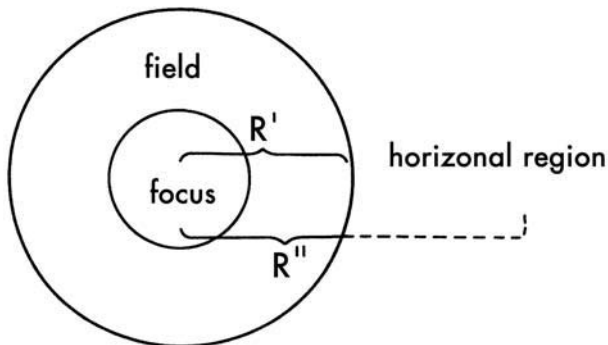

FIGURE 8.1 Focus Field Horizon Structure

to be ignored, unattended, or “forgotten.” *Ordinarily one* ignores the horizon, and even when one turns to the question of the field itself this question may remain latent and implicit. In this sense horizontal questions are “far” from the ordinary or central regions of experience and concern. By contrast, the question and noting of the horizon is in a sense *extraordinary* in what it calls for.

Yet if the horizon is that which situates the very field of experience itself as the field situates its center, then to ignore it is to risk at the least the peril of incompleteness in relation to exploring the limits of experiential phenomena. Insofar as second phenomenology makes the question of the horizon thematic, it is in line with but more radically developing the direction of thought already opened by first phenomenology. The first task for second phenomenology is to raise the question of the appearance of the horizon but without lapsing into the temptation to “leap” into that which is beyond experience in a positing and transforming of this “region” into that which it is not.

What at first seems the extreme in implicitness, once the question of a horizon is raised, yields gradually to some manifestations of horizontal phenomena with ordinary experience. This was also the case with field appearances which, once pointed out, became obvious in general outline. But with horizontal phenomena the problem remains the difficult one of locating them, since noematically horizons are the furthest remove from focal awareness, and noetically there is need for a certain “indirection” in eliciting their sense.

I return to my ordinary visual experience with an intentional involvement with the clock. It sits over there on the shelf behind me, not now appearing within my gaze. But as I turn my head the clock’s presence comes into the field and I am not surprised. I have expected the “invisible” to become “visible,” for in the sedimented beliefs that I have, I selectly “know” that just as the field transcends the thing, so the World transcends my opening to it. To name the horizon in relation to the visual field is to name the World. But in the very way in which I take the World for granted I may miss the phenomenon of horizon.

This first location of horizons as the place within experience, where the enigmas of withdrawing and absence occur as the “signs” of “transcendence” appear, has until now been expressed in terms of the borrowed clarity of a visualist approximation. The horizon of the visual field shows itself most easily as a spatial signification, a border or limit in its first appearance. And although vague, it has a shaded-off shape that is roundish.

With the auditory turn, however, the horizon does not show even such vague spatial significations except as thresholds of hearing. We are so situated “inside” the auditory field that its indefinite extent is not detected

primarily in spatiality. It may be “spherical” in the sense that this “opening” extends indefinitely outward such that we are “surrounded by” the fullness of auditory spatiality. But in the “strength” of sound a horizontal presence is discernible *temporally*. It is indeed the place where the auditory dimension of horizon is most dramatic.

As I listen to music on the radio, the notes “well up” out of the “nothingness” of the future and “trail off” into the horizontally equal “nothingness” of the past, and the sense of horizontal “absence” is the experienced temporality of sound. These sounds “give themselves” into presence and then “fade out” in the temporal dance of the auditory dimension.

In the previously located ability to shift the auditory temporal focus so that listening may search out the “leading edge” of sounds just coming into presence or follow the sounds as they “trail off” into the reverberations of the just-past of retentions, I also vaguely and indirectly detect the temporal horizontal limit of auditory experience. My expectant protentions and my most intense retentions always “break off” at horizontal limits.

In such variations that gradually elicit the sense of the horizon, I note that the general characteristics of the difficulty and the implicitness of horizontal discernment remain isomorphic with those characteristics noted in visual experience. The horizon is that most extreme and implicit fringe of experience that stands in constant ratio to the “easy presence” of central focusing. There is also *a resistance* offered by the horizon. It continually recedes from me, and if I seek for sounds and the voices of things, I cannot force them into presence in the way in which I may fix them within the region of central presence. I must *await* their coming, for sounds are *given*. But when they are given they penetrate my awareness such that if I wish to escape them I must retreat “into myself” by psychically attempting to “close them out.”

Here the attempt to describe horizontal phenomena comes on a language already partly Heideggerian. To *describe* the horizon calls for such language, for it is a correct description of the phenomenon of the horizon. Once located, the horizon as that limit to experiential presence may be described at its borders. There the horizon is a *receding*, a *withdrawing*, that which is *beyond* what is in presence. The horizon is the limit where presence is “limited” by *absence*. The horizon continually withdraws so that its *open* “region” is itself never present. A second phenomenology brings up the question of absence.

All of the above are *descriptive* of the horizon as a limit. But if now the horizon is located as such a limit, and it is understood that the double ratio of focus to field and field to horizon obtains, then the absent, withdrawing region may be viewed as that openness which situates the whole of experiential presence. What is present is always found “inside” or *within*

horizons; what is “not given” locates what is given. But although this borders on metaphysics, it is not metaphysics; at least so long as the open horizon is not made into what it is not: a spurious form of presence. “In itself” the horizon continues to be *hidden*, to withdraw, to present itself as the open region. But even such a recognition of the nonpresentability of horizon as it “is” beyond, in relation to the double ratio, allows one to characterize what is present, the field of experience, as being in an *abiding expanse within which things are gathered*.

Within the auditory dimension one may add the characteristics of horizons in terms of temporality. In the lecture, “Time and Being,” Heidegger speaks of an *Event* as a *giving*. Being, which is that which comes-into-presence, that which is (already) gathered, is the *given*. But at the horizon one may note the giving, the *e-venting*, the point at which “there is given” into what is present.² Nowhere is this more descriptive than in the experience of listening. The sounds “are given,” they come unbidden into presence, and humankind, in listening, is let in on this e-venting. Listening “lets be,” lets come into presence the unbidden giving of sound. In listening humankind belongs within the event. And as a presence, the sound is that which *endures*, which is *brought to pass*, the sound *whiles away* in the temporal presencing that is essential to it.

Nowhere has this phenomenological language been more descriptive of the phenomena, nowhere more literal, and nowhere more Heideggerian. Yet in relation to horizontal phenomena this is proper description. Presence is situated within its horizons, and at the extremes of horizontal limits can be discerned the “coming-into-being” out of the open and absent giving (*Ereignis*) and the region (*Gegnet*) that is “beyond” presence.

But in pushing horizontal description to its own limits, one further identification is called for. How is the horizontal “absence” that “sends” that which is received to be auditorily and temporally characterized insofar as it is heard? The clue lies in the enigma of *silence*. Silence is *a dimension* of the horizon.

The enigma of silence is in how it is “given in absence.” Here the full enigmas of language necessarily meet the enigma of experience faced with the question of horizons. What “is” in the language that describes presence is sound rather than silence. And until the question of a horizon is raised, it would be quite possible to fail to discover silence. Experientially, I cannot escape sound. If I return eidetically to the field presence of sound it is continuous.

There remains, however, a sense in which silence is “given in absence,” and its withdrawing horizontal absence may be detected in the most mundane of experiences with things. Silence belongs to those mute objects that have pursued philosophy through the ages. Silence belongs to the syncopation of

experiences in which what is seen seems silent while what is not seen may sound. In this one could almost say that silence is a “visual category.” The pen on my desk, the vase on the mantle, the tree now still in the absence of a breeze, lie before me in silence, until echo or contact awakens a sound.

This is a *relative* silence. Silence adheres to things hidden relatively within present experience. In Husserlian terms, silence belongs to the “empty intention,” the aim of intentionality that is copresent in every intention but that is the “infinite” side of intentionality that does not find fulfillment. There is a “depth” to things that is revealed secretly in all ordinary experience, but that often remains covered over in the ease with which we take something for granted.

For a brief moment, returning to visualism, this “depth” may be noted in the phenomenon of perspective. When I view a thing it presents itself to me with a *face*. A deeper and more careful analysis reveals that it is not just a *surface* face, but a face that is an appearance that presents itself as “having a back” as well. The “illusion” of depth which is possible for stage settings and two-dimensional pictures is possible only on the basis of a “real” depth that belongs to naive existential experience. The thing “transcends” its present face in its “absent” but intended back. The present is bounded by what is meant, or intended, which is the *adherence of horizon to the hidden side of the things*.

In this sense the thing may also be spoken of as having a horizon. Its hidden depth, its absent profiles which, while they may be given, are always those that recede when the thing is presented before me. And, here, too, the descriptions of horizontal phenomena continue to hold true. The thing displays a constant ratio of present to hidden, of visible to invisible.

Auditorily this hidden depth is silence. In its relative horizontal features silence lies hidden along with the sounding that presents itself. But silence, as in all horizontal features, is not a matter of contrast or of opposition as such. Silence occurs in adumbrations of the soundful to the silent. Even prephenomenological understandings of listening have their versions of this “shading off” of sound toward the silent. Just as the visual is copresented as a face in profile and an intended absent depth, so in listening there is a sound which shades off into the copresenting “emptiness” of silence. Silence is the “other side” of sound. Relative “absences” of sound have often enough been understood to belong properly to “meaningful” auditory experience. The pauses, or rests, in musical phrasing add to rather than subtract from the totality of the music. In speech silence often indicates either the stopping of a line of thought or a transition, but silences can also be filled with their own significations.

There is, moreover, an aspect of intentionality that “gestures toward” silence. In listening to music, particularly reproduced music, there is the

experience of the *intrusion* of unwanted sound. The hiss, hum, and static that may occur distracts, and one “gestures toward” the silence that allows the music its “purer” presence. Ideally, if music is to reach its full presence, it must be “surrounded” or “secured” by a silence that allows the sound to sound forth musically. This is one of the aims of a set of headphones that do not so much improve the music as help close out the other sounds and thus procure a relatively “surrounding” silence.

In the adumbrations of sound toward the silent there is also a relative silence that is “filled” with signification. In conversation when the other is silent there is also a “speaking”: we see the face which “speaks” in its silence. We feel the flesh which “speaks” in its silence. There is an adherence of speech to the silence of the other.

Such adherences within relative silence enrich with auditory depth things and others. Even mute things may “speak” in a silence that carries the adumbrated adherence of sound to presence. I look at the postcard that arrived recently from Japan. It depicts four peasants running from a sudden rainstorm. They hunch under grass hats and mats as they seek shelter from the wet coldness of the rain. And if I look intently at the picture, perhaps mindful of the dictates of a Zen passage read long ago, I detect the adherence of a certain auditory presence to the picture. I “hear” the rain and “listen” to the peasants running and to the rustling of the mats. The muteness of the picture “sounds” in its relative silence.

But it is not as if “silence itself” were discovered. The silence of horizontal phenomena continues to withdraw, but in its withdrawing may be heard the *giving*, the eventing that sound is in its coming-into-presence. *Beyond* this limit silence continues to escape. Heidegger has characterized the horizon in this respect as a *Nearness* that in its near distance has at once the character of refusing and withholding. He also called it “the hidden nature of truth.”³ It is revealed only in the withdrawing: “the horizon is but the side of that-which-regions turned toward our re-presenting. That-which-regions surrounds us -and reveals itself to us as the horizon.”⁴ And here are also reached the limits of a “direct” description in the enigma of giving word to this horizontal openness. “Any description would reify it [that-which-regions] . . . nevertheless it lets itself be named and in being named it can be thought about . . . only if the thinking is no longer a re-presenting.”⁵ Such a thinking as is appropriate to the horizon which shades off into its “absolute” beyondness can only be characterized as a thinking which is a *waiting*. Waiting is the limit of all “empty” intentionalities. Waiting is a “letting be” which allows that which continuously “is given” into space and time to be noted. Auditorily this is a listening to silence which surrounds sound. “Silence is the sound of time passing.”⁶

This page intentionally left blank.

Part III

The Imaginative Mode

This page intentionally left blank.

Chapter 9

The Polyphony of Experience

The first movement of a phenomenology of sound and listening has taken its first step in what may be regarded as a preliminary survey of the auditory terrain. It began with first approximations and the center of focal listening. It moved from that listening to the voices of things “outward” and from there to the listening for the silence of the relative and open horizon of silence. This survey has been attentive to the voices of the World.

This is phenomenologically appropriate, for there is *a primary listening* that precedes our own speech. This is whether one considers the matter as an issue of personal history—I hear the voices of others, of things, of the World long before I speak my own words—or as a matter of the correct phenomenological procedure which begins with noema before taking up noetic acts. Phenomenologically the “self” is modeled after the World which takes primacy in its first appearance.

The movement toward a more detailed review of the auditory terrain is a movement that accelerates the approximations to *existential significations*. The sounds that we hear are not “mere” sounds or “abstract” sounds but are significant sounds. In the first instance listening is a listening to *voices*, the voices of language in its broadest sense.

Existentially things “speak.” Heidegger has pointed out, “Much closer to us than all sensations are the things themselves. We hear the door shut in the house and never hear acoustical sensations or even mere sounds. In order to hear a bare sound we have to listen away from things, divert our

ear from them, i.e., listen abstractly.”¹ The things of the world sound in their own way. Things, others, the gods, each have their *voices* to which we may listen. Within auditory experience there is this *primacy of listening*.

Not only do things, others, the gods, and ultimately I “speak” in distinctive voices, but each has its own way with language. For within auditory experience I find myself already *within* language. It is already there. Existentially there is already “word” in the sounding wind that brings things, others, and the gods to me. There is a sense in which within experience a “prelinguistic” level of experience is not to be found. The “prelinguistic” is the philosophical counterpart to the “preperceptual” bare sensation that if found at all is found by diverting one’s ears and eyes from the objects.

Sounds that are heard as *already meaningful* do not show us the “lost” beginning. The actual history of man who speaks before he learns to embody word differently in writing and in wordless symbols does not show us the hidden genesis of the word. Neither do prescientific and preliterate languages show us the beginning. Not even the child’s “learning” of his first word, which contains in itself however latently the “whole” of language, reveals the genesis. Long before he has learned to speak he has heard and entered the conversation that is humankind. He has been immersed in the voices and movements that preceded his speaking even more deeply in the invisible language of touch and even that of sound within the womb. Listening comes before speaking, and wherever it is sought the most primitive word of sounding language has already occurred.

The presence of word *already there* for listening is also what I find if I inquire into myself. For wherever I find myself I already stand in the midst of word. My memories do not give me that “first word” that I uttered as a child or even the “first word” I heard from my parents. This lies beyond the horizon of my memory and appears if at all as an already mythical tale related to me by others.

Nothing gives me the “lost” beginning of word spoken by voice either as that which is built up or as that which occurs at a stroke. Neither is there a need for phenomenology to search for such a beginning. If I listen, I may begin in the midst of word for there is a *center* to my experience of language. It is that strange familiarity that lies in the very conversation that shows things, others, the gods, and myself. *The center of language is located in the voiced and heard sounding of word.* From this center I may proceed “outward” toward the horizons of sound and meaning that embody significance within the World.

The voices of the World find response, an “echo,” in my own voice that takes up the languages of the World. My “self” is a correlate of the World,

and its way of *being-in* that World is a way filled with voice and language. Moreover, this being in the midst of word is such that it permeates the most hidden recesses of my “self.” It is for this reason that the more detailed review of the auditory terrain that follows not only moves ever closer to existential significations, it also takes note of a modality of experience so far barely noticed in the first listening to the voices of the World.

To this point the themes that have been followed could be characterized as *monophonic*. It is as if I, the listener, have been primarily a “receiver” of the voices of the World. As experiencer I have not yet spoken, neither have I yet heard all there is to hear. In particular I have not yet paid attention to that second modality of ongoing experience, the *imaginative mode*. With the introduction of a second modality of experience, in addition to what has been the predominantly perceptualist emphasis, listening becomes *polyphonic*. I hear not only the voices of the World, in some sense I “hear” myself or from myself. There is in polyphony a duet of voices in the doubled modalities of perceptual and imaginative modes. A new review of the field of possible auditory experience is called for in which attention would be focused on the copresence of the imaginative.

If the first survey weighted perception, it did so in terms of what has been taken as primary in first phenomenology. Yet even within first phenomenology there is also a countertendency. Husserl elevated imagination as fantasy to the level of the privileged “instrument” for critical phenomenological reflection itself.² His paradigm, at least implicitly, was the thinker such as the logician or mathematician who could reconstruct whole “worlds” by himself. But this elevation of the imagination could equally have been properly modeled after literary or poetic or artistic thinking that also surveys the possible.

Husserl’s use of imagination, moreover, often revolved around the reproductive or representational capacities of imagination. Here imagination reproduces what was previously perceptual, but in the assumption that it does reproduce the other modes of experience lies a threat to the primacy of the perceptual itself. In imagination, even at the level of variations, there is already an “excess” that carries it beyond perception. Hidden in this “excess” are both certain aspects of “self-presence” and of a fundamental liaison with the World. The “innermost” is *not* distant from the “outermost.”

The imaginative mode, to be considered very broadly as ranging from the “empty” suppositions to the most concrete “images” of thought, contains within itself the variations of “self-presence” and “thinking” that pose such difficult questions to philosophy. Of course here the primary question of context is one directed to the various forms of *auditory imagination*. What

is it that I “hear” when my listening is to the “second voice,” the imaginative voice? What is that listening that occurs within my self-presence and that accompanies the presence of the things and of others in the perceived World? If the “self” arises phenomenologically strictly as a correlate to the World, a correlate that is in a sense discovered only after discovering the World, it also hides within itself and its imaginative acts (which hide themselves from others) a kind of autonomy.

In the auditory dimension the imaginative mode is a matter of “voice” in some sense. Its center, suggested above, may be located in a clue provided in the history of phenomenology by Merleau-Ponty.

In the discussion of the body as expressive, Merleau-Ponty notes that what is usually taken as an inner silence is in fact “filled with words” in the form of what will here be characterized as “inner speech.”³ *Focally, a central form of auditor versus imagination is thinking as and in a language.* With and around this phenomenon revolve many of the issues that relate to specific human experience and self-experience.

The second survey that begins its investigation of the polyphony of experience binds what is “innermost,” the imaginative, with what is also the broadest in human experience, the *intersubjective*. It is the *voices of language* that assume a focal role in human imagination in its auditory dimension.

Initially there is nothing more “obvious” than the familiarity of human speaking and listening. Wherever humankind is found it is found speaking. Through the polymorphic shaping of sound sing innumerable languages. Languages bind together and separate humankind. Otherness and strangeness is dramatic in the difference of tongues, but there is also the human ability to learn to “sing” in any language.

Language also lies in the interior. Inner speech as the hidden monologue of thinking-in-a-language accompanies the daily activities of humans even when they are not speaking to each other. The voices of others whom I hear immerse me in a language that has already penetrated my innermost being in that I “hear” the speech that I stand within. The other and myself are co-implicated in the presence of sounding word.

Phenomenologically I already always stand in this center. The voices of language surround me wherever I turn, and I cannot escape the immersion in language. The voices of language have already penetrated all my experience, and this experience is already always “intersubjective.” And if this experience of the omnipresence of language that comes from others and settles even into the recesses of myself is “like” the experience of surrounding, penetrating, pervasive sound, it is because its ordinary embodiment lies in the listening and speaking that embodies the voices of language. Voice is the spirit of language.

But if the voices of language are the central theme for the polyphony of experience, a survey of the wider reaches of the imaginative mode is also needed. Before the dominant feature of the “inner landscape” can be determined, a series of approximations which more clearly locate it is called for. The voice belongs to a vaster polyphony of perceptual and imaginative experience.

To begin with the ordinary, as I turn to “inner” experience in the mode of the imaginary, I note that these experiences may “echo,” “mimic,” or “re-present” any “outer” experience. Imagination *presentifies* “external” experience. *I see* the butterfly light on the sweet pea; I close my eyes and recollectively imagine the same event. I heard the distant foghorn in Port Jefferson, but I can imaginatively remember it now. These re-presentations may be exceedingly varied in form as memories, recollections, or fantasies, and so on but in each of these they display themselves as *irreal*. It is not that irrealty is lacking in vividness; a lack of vividness may be a contingency of a particular person’s imaginative ability, or it may be the result of a lack of attention and “training” in imaginative acts. But the irreal presence is marked by “immanence” as “mine” and as “hidden” from the other.

But if the irrealty of the imaginative contrasts with the sense of actuality and transcendence displayed by “outer” experience, there remain many respects in which imagination displays a structural isomorphism with perception. Imagination, like perception, is susceptible to further and further refinements, discriminations, and enrichments as the rich imaginations of artists have revealed through the centuries. Auditorily Beethoven was able to imaginatively “hear” an entire symphony at will. Even after deafness his “inner hearing” did not fail him as the magnificent Ninth Symphony so well shows.

With this variability and polymorphic capacity for refinement possible in imaginative modes of the experience, the dangers to a descriptive phenomenology are encountered again in the temptation to arrive too soon at a superficial, if apodictic, level of discovery. The richness of imagination is at least as complex as that of perception.

I return to preliminary imaginings. If various forms of the irreal may re-present perceptual contents in the form of memories and recollections or fantasies, there also occurs in each of these forms the “inner” capacity to *vary presences indefinitely*. Usually this capacity of imagination is centrally located in fantasy, but the irreal presentifications in each of the forms of imaginative activity may occur *either spontaneously or at will*.

I may remember the sounds of the workmen arriving with their usual clatter yesterday in the mode of a mnemonic repetition of that event, and this remembering may occur “at will” or “spontaneously.” Or, if I am imagining as a type of fantasy, I may lie back daydreaming, allowing my “thoughts” to drift

before me. Equally, if I am searching out a problem, I may, in a disciplined exercise of variations, try at will this and then that alternative.

Between spontaneity and at-will presentifications lie other gradations of possibilities. The occurrence of one imaginative content may spark by “association” a series of others, or a “line of thought” may lead “linearly” like a deduction to something else, and so forth. But in the midst of at-will imagining, particularly in fantasy, further possibilities of the “inner” modality show themselves. In fantasy the variations are not merely unreal, they are “free” of the intentional re-presentations that mark recalled and mnemonic occurrences. Thus I can imagine centaurs, satyrs, creatures from Mars, or the catalog of imaginary beings classified by Borges. This fantasizing applies to auditory imagination as well. I may “hear” the stellar music of *2001* or turn the enchanting songs of humpback whales into a chorus at will.

The range of variability of “inner experience” is as wide and as susceptible to learning as that of “outer experience.” But in some respects there is an “excess” of imagination over perception. Imagination is not a mere mimicry of the perceptual. This is not to say that imagination is absolutely free, because, as previous phenomenologies of the imagination have shown, imagination like perception has its own distinctive structures and possibilities.

Imaginative acts also implicate the “self.” As “my” imaginings, particularly those that I presentify to myself at will, the sense of an “inner self-presence” entices the very notion of a “self.” In imagination I am able to “experience” myself. But the way imagination “shows” a “self” may vary considerably. In class, concerned with showing existential possibilities of imagination, I ask the students to imagine experiences that they have not in fact actually experienced before and to describe what they imagine. One student imagined himself jumping from an airplane in a parachute, an experience he had never had but desired to have. On more specific inquiry we discern that he imaginatively “feels” the rush of air on his face; he “sees” the ground rushing up to meet him; he “hears” the airplane receding in the distance. Imaginatively the full play of the “senses” is vividly presentified.

A second student, however, describes the same type of experience very differently. He “sees” himself jump from the airplane. He does not “feel” the wind or “see” the rushing of the ground to meet him but “sees” himself “out there” as a “quasi-other” jumping and falling toward the ground. On repeating these exercises in different classes, this difference consistently emerges. “Empirically” some self-imaginings are experienced as occurring “in” and “from” one’s own body, while others are *objectified* in that they place themselves “out there” apart from their sense of body as an “objectified quasi-other” in the imaginative experience.

But once this difference is clarified and compared, most of the students find that they can vary embodied and objectified self-imaginings at will. However, it remains so that in the objectified mode it is almost always the case that the “quasi-other” who is my “self” is not only “apart” from the sense of “being in” one’s body but is displayed without the full range of sensory imaginative presence. There is a lack of a “feeling in” my “self” as “quasi-other.”

Again, these imaginative possibilities as spontaneous or at will, as embodied or objectified, are also locatable in auditory imagination. Spontaneously, though in the mode of unreal imaginative recollection, the brilliant passage from the harpsichord solo heard last night in the Purcell Room may occur to me. Or, if specifically attending to this occasion, I may at will try to remember the continuo of the cello in the trio sonata which opened the concert. In auditory fancy I may also at will imagine a set of disharmonic tones and in fact either build them up “one by one” or “hear” them occur in a gestalt.

Embodied and objectified auditory imaginings may also occur. One dramatic and sometimes “pathological” phenomenon are the well-known disembodied “voices” heard especially by schizophrenics. “Voices” occur spontaneously, and sometimes the patient is not even able to tell if it is his own voice or that of an other; whether it is from within or from elsewhere. But far less extremely, it is possible to “disembody” one’s own voice in auditory imagination and hear it as from a tape recorder. Here in an imaginative version of an auditory mirror are elicited a series of difficult problems that revolve around imaginative self-presence. What, then, is the form of an embodied auditory imagination? Do I, whenever I turn to “hearing myself” speak, objectify my voice as that of a “quasi-other”? Or does there lie so close to “me” a most familiar and thus most difficult to elucidate embodied auditory imagination that is the ongoing presence of a dimension of my own thinking, an “inner speech”? Although such a suggestion is almost too easy and too obvious, its location calls for yet further approximations.

Do, for example, the structures of focus, field, horizon, spatial, and temporal features appear in the imaginative mode, and if so in what form? As one enters further and further into the “observations” called for, more and more difficulties are encountered. These difficulties, however, are not ones that are to be blamed on the “introspective” nature of imagination rather than the “extrospective” nature of perception or because imagination cannot be checked “publicly.” In that respect imaginative contents are no more enigmatic than perceptual ones, for I no more have the other’s perceptual hold on the World than his imaginative one. And in other respects

he can as easily report his imaginative activity to me as he can his perceptions. Phenomenologically there is as much intersubjective validity to the exploration of imagination as there is to perception, and in both one must first seek “for himself.”

What does make the “observation” of imaginative phenomena difficult is the very essential variability and ease of presentification that belongs to the noematic presence of the imaginative content. It is of the very essence of the imaginative noema to be easily changeable and variable. For no sooner do I “think of it” than it is “there.” Its dissolubility, its rapidity of transformation, its vivid but “evanescent” presences make it difficult to “fix” what is imagined.

This “flux” of appearances, the apparent “insubstantiality” of them, the “flow” of them as events have shown themselves before. This characterization of imagination is “like” the first characterization of the *auditory dimension*. Moreover, the “flux” and “flow” of these features implicate again the sense of temporality that belonged dramatically to listening. As in the first exploration of the auditory dimension, one suspects that these features belong as much to the *first stage of reflection* as to the phenomena. The Heraclitan dynamism of the imagination may be but the preliminary appearance of its being, but there may also be a *secret liaison* between the “flow” of imagination and the “flow” of the auditory. Each begins in the same grammar.

Given this initial difficulty regarding imaginative presences and a suspicion about what occurs at a given level of reflection, the question of structural features becomes a matter of more subtle and careful variations in imaginative intuiting. There is also to be preliminarily considered the same problem facing an investigation into the imaginary as previously discerned in relation to the perceptual. In the traditions regarding the imagination the “image” has become as discrete and “atomized” and isolated as the infamous “sense datum” of perceptual experience. But in imaginative experience there is an even more difficult problem again located in the presence of the imaginative noema. This difficulty emerges in relation to the question of a focus-field relation in imagination.

I imagine a philosopher’s Pegasus, varying his color—now purple, now white, now green—and varying his shape—now with ragged wings, now with smooth wings. In each variation he may appear vividly in the mode of irreality. There is no doubt that the variable Pegasus “stands out” in imagination. But no sooner do I raise the question of a field than a difficulty emerges. For if there is a field it “shows itself” not only as implicit but so obscure and indefinite and unstructured that I begin to wonder if I presentify a field on demand. Yet, when I return to further and more extreme variations, I do begin to detect the sense of a field.

I imagine a transparent Pegasus, which I now “see,” and here I begin to detect that he is etched out against a background of almost indiscernible color and extension, which is a field nevertheless. But *unlike* the focus to field relationship in perception, the starkness of contrast between the core figure and the vagueness, indefiniteness, and much higher degree of implicitness, the contrast is so marked that without careful variations it is possible to almost miss the field. Of course one existential possibility of a field may be detected immediately on raising the question, for I can imaginatively “supply” a vivid field for my Pegasus and make him in his purple variation stand out against a green ground. But by not attending to background, the imaginative field remains much more starkly indefinite and much further a fringe phenomenon. Here we come on a difference between the perceptual and the imaginative modalities. There is a higher degree of contrast possible between focus and field in imagination than in perception.

But if the contrast between focus and field is a matter of severe degree, there is another respect in which an even greater contrast occurs. In perception, regardless of how fringe-like the presences are, there is a *constancy* of perceptual presence so long as one is experiencing at all. But in imagination a whole dimension of imaginative experience may be “turned off” and absent. Neither focal figure nor field background can be detected. This is most easily noticed in relation to the more often neglected dimensions such as those of smells. It is quite certain that I find no ongoing imaginative smell signification except as bidden or as may occasionally occur spontaneously. In fact some persons are quite surprised that they can imagine smells, and this may at first be difficult. It should also be noted in passing that there are also cases in which a person is lacking entirely some imaginative dimension such as that of visual imagination in which case there is an “imaginative blindness.”⁴ Apart from these cases, the fully dimensioned imaginer finds it quite simple to “turn off” one or another dimension of imaginative experience. Speculatively, this may be one source of the temptation to “atomize” and make discrete global sensory experience. The imagination in its variability that “exceeds” that of perception “allows” this possibility. In this aspect imagination, *although not perception, is* latently “analytic.”

If an entire dimension of imaginative experience may be “turned off,” when it is “on” it continues to display itself as “like,” its perceptual modality though different in its degree of internal relations between focal and field aspects. Colors, shapes, extendedness, figure and field, even three-dimensionality may be noted in visual imaginations. But there is one interesting respect in which the imaginative visual field is *not* isomorphic with its perceptual modality. In regard to field shape the imaginative visual field “exceeds” its perceptual modality.

I imagine a green bee buzzing “before me.” At will I gradually move him to the side, then to the *back* of my head; yet I still “see” him in imagination. Here, however, is reached one of the most difficult to determine imaginations. I wonder about this possibility. Have I subtly deluded myself and disembodied myself? This variation is indeed easy to perform: I imagine myself sitting in a chair with the green bee buzzing behind me, but I am now “seen” as a “quasi-other.” This is distinctly different from the imagination of the green bee “behind” me in the embodied form of imagination; yet he presents himself here, too. I continue to “see” the bee behind me, although I have to admit that his imaginative presence does change. He is now no longer only a “visual” bee, he is also “felt” and “heard” as in the cases of the adherence of significance beyond the limits of a horizon. He also is “visually” imagined. In this, the shape and limit of the imaginative *field* “exceeds” its visual limitation of being “before” one. But in the imaginative modality this “excess” is one that has already previously shown itself in other field shapes including that of hearing. In a “likeness” to an auditory field an imaginative “visual” field is omnidirectional. In imagination the field-shape possibilities of the visual dimension are closer to those of an auditory field-shape than in the perceptual mode.

But in the question of the dissimilarity of imagination and perception, the “turning off” at will of what is for perception a constancy, raises another line of inquiry. Is such obliteration of entire imaginative dimensions a relative or an absolute possibility, or is there *continuously* some form of imaginative self-presence? Here a further descent into the imaginative mode is called for.

This question whether it is possible to completely “turn off” the “thinking self” insofar as it is imaginative is not without purpose. But its purpose is not to answer the absolute question, for if this were possible then the answer might be one that must face the problem of cessation of experience. It is rather an indirect way of eliciting the modal possibilities for locating the continuities that show themselves as “contingently” dominant in the “thinking self.” For the suspicion is that at least so long as one has awareness, *some* modality of imaginative “self-presence” occurs. It is in this line of inquiry that further approximations to a polyphony of experience may be noted.

To more precisely localize and isolate such dominant continuities another set of graded reflections must be addressed to the polymorphy of global experience in both its perceptual and imaginative modalities. The first task is one of detecting the *copresence* of perceptual and imaginative modalities.

Simple variations show this quickly but in such a way that there is again a graded set of what is focal and what is fringe within the multiplic-

ities of global experience. That is, globally anything that is present to any degree will be placed within a stratification that is gradated from a “center” of attending focus to an extreme fringe, “vague” presence. This gradation and ratio show themselves in the simple variations that locate the existential possibilities of perceptual and imaginative copresence.

I am sitting in my chair, deeply engaged in thought, perhaps specifically going over a set of imaginative variations about a certain problem. The perceptual awareness of my surroundings as a whole is “drawn in” and becomes fringe-like in character. My usual bodily sense of fringe “weightiness” and “locatedness” gradually transforms into an almost “weightless” feeling, and my feet, propped up on the footstool, almost seem to “disappear.” I am so deeply absorbed in my thinking that my bodily experience and the surroundings are “almost forgotten.” The “inner attention” is the focus of global experience in contrast to the now implicit “outer” fringe. But suddenly my daughter bursts into the room to announce her latest success at school. I jump, and with an almost instantaneous “switching” of focus I find my global experience “outwardly” directed.

In the case described above, however, the polymorphy of imaginative “thinking” copresence is detected. In ordinary situations it shows itself as “weighted” toward either an “inner” or an “outer” focus, a ratio of focal-to-fringe awareness. When I am engaged in an activity, particularly a demanding bodily activity, the converse of the absorption in thought occurs. I chop wood for the evening fire in Vermont. Here I am “in” the ax as my energies and forces are directed through the wood. I am “outside” my “inner” self, not to be distracted for the very obvious reason that if my attention was not so concentrated, I may well lop off my foot. Here, while there is also an “inner” awareness, it is fringelike with respect to the active embodiment in the chopping.

A third variation begins to show more balance in copresence. I sit down to read, the book lies before me “perceptually,” and I must “see” *in* the words the thought that they may bring me. Of course it is not the “shape” or the “surface” of the letters that I attend to, but the “meanings” in the words. But while this activity proceeds I may find myself “wandering off” into my own thought, perhaps stimulated by what I have read, and before long the reading has receded and become “mechanical” as I move from the meaning in the words to focus on my own “inner” meaning thought. One or the other side of imaginative-perceptual copresence ordinarily takes precedence. Such variations establish the essential possibility of copresence but do not exhaust it.

I press the investigation further. If it is possible for two modalities of experience, perception and imagination, to be variably copresent, is there

any structure more detailed that allows this copresence to be heightened or lessened? The new line of inquiry leads into considerations of the dimensional characteristics of imaginative-perceptual copresence. I begin to note a series of *resistances* within the possibilities of general ratios of focal-to-fringe experiences.

I look at the picture of the sailing yacht on the wall before me. All the while I am thinking of how much I desire to have such a yacht, but I also tell myself that this is a luxurious dream. Or I gaze almost blankly at the pile of correspondence on the desk while thinking of the agenda for tomorrow's meeting. Here, still within the general structure of a variability of focus and fringe, there is a ratio of copresence, for there is some awareness of both the thought and the perceptual presence. There is a "distance" between what is imagined and what is perceived. But the "distance" is more than a "distance" of imagination and perceptual modalities, it is also a "distance" of dimensional aspects. I see the yacht, but I "think" in "inner speech" what it is I think about the yacht.

If now I look at the yacht and try at the same time to visually imagine it, I find *a resistance* that shows itself in several ways. First, I find that in the attempt there may be a subtle but detectable *alternation* between the imagined and the perceived yacht. Within the *same* dimension of experience there is a conflict between imagination and perception; there is the need for a kind of "distance" for the copresence to be easy and distinct. The "distance" is a matter of a *harmony* of copresences within polymorphy.

Such harmonies of the "inner" and the "outer" modalities is in fact quite ordinary. The commuter driving to work can be quite aware of the habitually experienced flow of traffic while at the same time intent on his plans for the day. So long as there is a "distance" there may be copresence. But within the same dimension the loss of that "distance" produces a resistance that may also take several forms. There is the already noted resistance to perceiving and imagining the same thing at the same time. There is also an occurrence that is frequent, but that also often escapes explicit notice. That is a *synthesis* of imaginative and perceptual copresence in the form of a very ordinary "hallucination."

This "hallucination" is one in which a particular type of copresence momentarily synthesizes such that in that moment what is "imagined" is "seen." If I am intent upon my reading, the ideas flow smoothly into my awareness, and I pay little specific attention to the words as such. But if my thinking begins to wander and gradually drifts away from its previous concentration, the reading gradually recedes but remains present. If I realize what is happening I may immediately return to the reading, but sometimes in the drifting of

thought I may think along a similar or related line of thought and suddenly may “see-imagine” what appears actually to be a “wrong” word. *Crescent* may be what is written, but I “see” it as the word *present*, as if in a “perfect” but momentary synthesis this transformation had occurred.

A moment’s reflection and rechecking shows that the synthesis was momentary, but here the polyphony of the copresent modalities of experience “blended” so that the appearance was neither a “pure” imagination nor a “pure” perception.

This momentary synthesis of “inner-outer” is a moment where in the same dimension copresence comes together whereas ordinarily there is a resistance to this. The diagram in figure 9.1 illustrates this situation. What is ordinary here is the initial “distance” between the perceptual and the imaginative modes, although also ordinarily focal attention will be weighted on one or the other. But in the occasion of a synthesis (b), the moment of the particular “hallucination” of a “blending” of copresent awareness, this “distance” disappears.

But in the light of the resistances offered by perceiving and imagining the same thing in the same dimension, a complication must be added that in turn serves as a further indirect index for locating the role the auditory plays in “self-awareness.” The resistance posed by any synthesis in the same dimension of imaginative-perceptual experience is also a preliminary index for locating at deeper levels the roles of the dimensions of “inner” imaginative activity.

Thus while I am listening to music I may well imagine the flowing of colors, or, conversely, when I am looking at a painting I may auditorily imagine the baroque music that I believe goes with the scene. But when I try to both imagine and perceive the same thing at the same time, *in the*

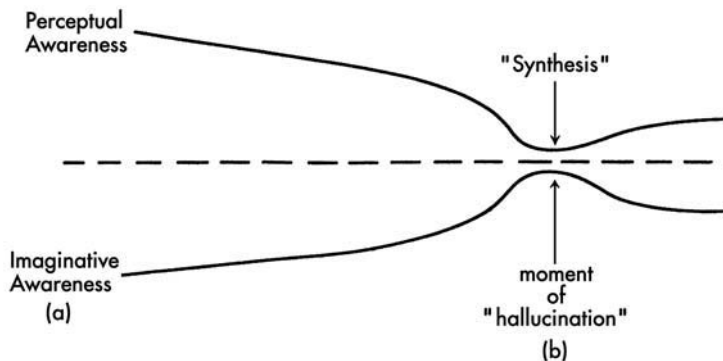

FIGURE 9.1 Perception-Imagination Overlap

same dimension of experience, I immediately run into a resistance that gives way to the alternations previously noted. There is a resistance of the “identity” of the noema that is at stake here, but implied reflectively there is also the problem of the “identity” of the noetic act.

Before taking a final step toward isolating the role of auditory imaginative activity within the full range of the imaginative and perceptual polymorphy, a brief detour into what may have become troublesome regarding the survey of the imaginative mode seems appropriate. The review of the auditory terrain within the imaginative mode almost inevitably raises the question of “introspection” in respect to such investigations. And to compound the problem there is also a question of “contingency.” Although the objections associated with such questions often, if not always, betray an already strongly sedimented and often dogmatic “metaphysics” which presupposes distinctions foreign to phenomenology, it must be admitted that there are indeed different empirical habits of thought.

Phenomenology in its own way, however, must always plunge into “contingency,” because the existential possibility shows itself only in the midst of “contingency.” In terms of this “contingency” it is well established that certain persons have vivid and almost continuous visual imaginations, while others have no visual imagination at all. Others still are focally “linguistic” in their thinking. I think philosophers are often primary populators of this possibility, and more than one colleague has spoken of “thinking propositionally.” Moreover, in anticipation of the turn to auditory imagination in relation to language, it must also be admitted that there are “other” types of “languages” than spoken ones. This problem will be addressed below, but by way of preliminary considerations the overwhelming “empirical” observation that most “first” language is a matter of speaking and listening cannot be sheerly ignored. For what lies at the base is again the vast alternative posed by phenomenology *or* metaphysics. For metaphysics the problem of “contingency” more often than not serves as the excuse to overlook the *incarnation* of “thinking” in the modulated forms of embodied experience. For phenomenology the plunge into the midst of “contingency” is a matter of searching out the essential possibilities of how embodiment occurs.

The question in the midst of “contingency” is one that is gradually focused on the auditory dimension of experience. But at the same time precisely determining a sense of the imaginative is necessary. If there is some sense in which some form of copresence is continuously or almost continuously present, and if the isolation of a dominating form of that copresence in its appearance as an imaginative act is to be clarified, what is called for is a more and more “concrete” imaginative variation.

Symptomatically the “concreteness” of the variation may be illustrated in relation to approximating the experiences of those “unlike” ourselves. The situation of the blind person, who has already been noted as having a plenary quality to his experience; yet who is also poignantly “dominated” by an unknown visual dimension that invades the very depth of his social existence, cannot easily be “imagined” by one with sight. As soon as we attempt to genuinely “imagine” ourselves into this state we find a gradual “subtraction” of visual aspects will not do. A closer approximation might be the previously “constructed” imagination, which places us suddenly in the midst of creatures who have a “sense” other than ours about which they communicate, but about which we have no idea. Neither is it that we cannot merely “imagine” what they “experience,” it is that the very fullness of our experiential plenum excludes this possibility. *There is no way of exceeding horizons except totally.*

In contrast, to begin in the midst of “contingency” is to grant the actuality of that “contingency” but also to open the way to the most “concrete” of variations that show existential possibilities within human experience. The more narrow concern with auditory imagination already preliminarily suggested as a central dimension of human *thinking in language* is the place where that further plunge into “contingency” may continue.

This page intentionally left blank.

Chapter 10

Auditory Imagination

Not all auditory imagination assumes the form of inner speech. There are also the varied possibilities that surround thinking in a language, and which, without investigation, could hopelessly confuse the issue. In the most general terms, auditory imagination as a whole displays the same generic possibilities as the full imaginative mode of experience. Within the active imaginative mode of experience lies the full range from sedimented memories to wildest fancy.

In memory I can recall the voice of my grandmother's quaint Germanic "oncet's" and my grandfather's mumbled dinner grace beginning with, "*Komm'n Sie Jesu.*" In fantasy I can presentify and represent the sounds of the world. I can imaginatively hear the strains of a flute or a cello or both, or I can imaginatively fantasize a debate between two of my colleagues who are not on speaking terms.

Within the realm of the imaginative, auditory imagination may accompany other dimensional presentifications. I recall looking at a National Geographic map of the Middle East, and it presents itself irrealily in the imaginative mode. But to it I "add," while recalling the myriad faces of the peoples, the strains of a Near-Eastern wailing melody I once heard.

Both of these presentifications may then be "released," and they disappear. But I seek out the peculiarities of the auditory dimensional characteristics. I notice that there are distances and resistances between the imaginative and perceptual modes of experience regarding copresence.

There is a ratio of focus to fringe in the dual polyphony of perceived and imagined sound. Perceived sound, as in the case of “white sound,” or programmed background music, floats lazily around me, and I find I can easily retire into my “thinking self” and allow the floating perceptual presence to recede from focal awareness. But a series of variations illustrates that there are also distances and resistances in the polyphony of perceived and imagined sound.

If suddenly the sounds of the environment increase in intensity and volume, particularly if not constant, I begin to find a resistance to the maintenance of “inner” focus to “outer” sound. The perceived sound in its penetrating capacity disturbs my train of thought. Auditory interruptions of “thinking” are particularly noticeable. A sudden noise, the annual engine trial of someone’s hydroplane on the harbor, poses a serious distraction. I recall when living in another town the intrusions of the attempts of a nascent rock drummer whose practice sessions at an open window across my backyard made the truth of the statement *It’s so loud I can’t hear myself think* apparent. The intrusive presence of sound may penetrate into even my “thinking” self-presence.

A second variation of the “disruptive” quality of sound on the occurrences of auditory imagination and the continuities of “thinking” comes more pleasantly in the enchantment of music that can also overwhelm inner self-presence. In its sometimes orgiastic auditory presence the bodily auditory motion enticed in the midst of music may lead to a temporary sense of the “dissolution” of self-presence. Music takes me “out of myself” in such occurrences.

Each of these variations revolves around the penetration of sound into the very region of the “thinking self.” But while sound poses a threat of seduction in some of its occurrences that intrude “inwardly,” there are also possibilities of a copresent polyphony of auditory experiences of the perceptual and imaginative modalities. Here the variations begin, however, to leave the realm of strictly ordinary experiences and move toward more extreme variations. However, many of the following experiences are better known, and some are quite familiar to the musician whose auditory imagination is often better tuned than that of the nonmusician.

There is, in auditory imagination, the possibility of a synthesis of imagined and perceived sound as noted previously in a visual example. But in this case the auditory “hallucination” is not a matter of hearing one thing as something else but a matter of a doubled sound, a synthesized *harmonic echo*. I listen to a record of Vivaldi’s *Four Seasons*. In my new intensified listening I pay particular attention to the trailing off of sounds, following them in Husserlian fashion in their reverberations that meet the horizon of

retentiveness. I “hold on” to these notes as deliberately as possible as they trail off. After some attempts at “stretching” attention in this fashion, suddenly and spontaneously there occurs a fully “doubled” passage in the form of a harmonically synthesized gestalt. That is, the notes that were “trailing off” return, doubled as copresent with the next phrase as if suddenly two orchestras are playing, one slightly out of time with the other. But the momentary copresence of a “now-point” with the “just-past” sounds occurs as a full harmonic echo. Later I find that musicians following this period of composition had actually written such effects into their music.

Less dramatically, a variation of the above possibility is more easily detected not as a harmonic synthesis but as a fading reverberational echo of tones just passing off being vividly retained and “added” to tones coming into presence with a definite sense of “distance” such that the echo reverberation is distinguished from the oncoming sounds but also remains as a fringe effect. In exercises of extremely intense listening the doubling effect can produce dissonances as well as harmonies. However, in both the above-noted examples it is unclear what other roles an imaginative modality plays, if any, because the situation described above is close to being an auditory equivalent to the doubled sight that occurs when one crosses his or her eyes.

In all of the variations upon auditory polyphony cited above, forms of copresence show themselves as variations on harmonies or dissonances, upon musical sound. But if I try to imagine and perceive the same sounds at the same time, I find the same *resistance* previously noted. Again the sense of rapid alternations shows itself as the closest approximation to this lack of distance within auditory experience. In this there is an essential isomorphism of the structure of intentionality within perceptual and imaginative listenings.

Further variations begin to show related polyphonies which double perceptual and imaginative possibilities in different ways. I attend a concert, and while it is playing I begin, in fancy, to “embroider” the perceived piece of music with copresent imaginative tonalities. With some practice it soon becomes possible to create quasi-synthetic dissonances, adumbrations, variations on the actual themes being played. There is some evidence that this “distracted” though intense listening may have been practiced by Mozart, who was always accused of never listening to anyone else’s music but was busy creating his own version of it even in the presence of another’s music. In this form of copresence there remains a slight sense of distance between the modalities either in the sense of one being the “echo” of the other in a version of foreground and background attentiveness or in the form of alternating bursts of perceptual and imaginative sounds.

In all of the above-noted examples of auditory polyphony the forms of copresence maintain at least a minimal distance. The perceived sound is in harmony with or in dissonance with the imagined sound. A much stronger resistance is found in trying to perceive and imagine the same sound simultaneously. Here, if any success is achieved at all, close reflection shows a series of rapid alternations between focally perceived and imagined modes of experience. Here a clue is offered regarding an essential isomorphism of intentional structures in the perceptual and imaginative modes.

In spite of what historically has been a massive lack of philosophical attention to the phenomena of auditory imagination, the development of its possibilities, particularly in music, is worthy of investigation. For example, auditory temporal significance may be exceedingly accurate. In the case of Toscanini, tapes of original cuts of symphonies that had been recorded twelve years apart showed that his sense of time was accurate enough for the tempo of one symphony to be within microseconds of the other.

If philosophy has largely ignored the musical ear in both its perceptual and imaginative modes, it *has* attended to the problem of the “linguistic.” Although there has been a vast amount of work done on philosophical problems of language, little has been done concerning the examination of concrete forms of thinking as inner speech considered as a type of auditory imagination. In part, this phenomenon *as* a phenomenon of a special type of auditory imaginative activity may have been overlooked because of the long tradition of interpretation that maintains a “metaphysical” and “Cartesian” stance toward thought. This tradition takes for granted that thought is *disembodied*. Thus in spite of discussion of “mental word,” the persistence of a dualism of “acoustic tokens” and disembodied “meanings” continues.

But there are phenomenologically locatable reasons for the failure to locate “linguistic thinking” in inner speech as part of the auditory dimension. These reasons lie within the fragility and structure of the phenomenon itself. Inner speech as a form of auditory imagination *hides* itself. Yet in this hidden, fragile, and difficult to locate phenomenon are deeper existential significances for the understanding of *human being as language*.

Thinking in a language, inner speech, though hidden, is also familiar. And as in the case of all familiar phenomena the familiarity itself is a bar to thematizing the phenomenon. Inner speech is an *almost continuous* aspect of self-presence. Within the “contingency” of human language it is focally embodied in thought as an imaginative modality of spoken and heard language. As an *accompaniment* to the rest of experience it is a most “inward” continuity of self-presence and the hidden familiar presence of an experiential polyphony.

The first proximate variations within the auditory dimension displayed the intrusive capacity of sound to disrupt patterns and trains of “thought.” And the first indications of distances and resistances begin to foster a more positive suspicion regarding the location and role of inner speech as a special type of auditory imagination. However, further variations are needed to make this phenomenon stand out more clearly.

I return to variations on musical imaginative presence. When involved in presentifying the “embroidery” of an imaginative musical “addition” to the perceived music, I note that my inner speech ceases. I am “in” the music. I discover here a resistance to simultaneously “thinking in a language” and imaginatively presenting music. Contrarily, when, focused totally upon the multiplicity of imaginative phenomena, I find that I can easily imagine the philosopher’s centaur while continuing to “think” in inner speech. Such considerations are not conclusive, although as indirect indexes of the isolation of inner speech as auditory imagination they begin to narrow further the region of location.

Each of the above continues to be a variation in the midst of an often confusing wealth of experiential polymorphy. A reverse set of variations in the form of a detour into a pathology of listening serves to isolate indirectly and inversely the embodiment of language in inner speech. Defects of hearing and, most extremely, deafness symptomatically point to both the “contingency” of what is focally the role of inner speech and to the existential importance of the auditory in the human community. Helen Keller confessed that “the problems of deafness are deeper and more complex, if not more important, than those of blindness. Deafness is a much worse misfortune. For it means the loss of the most vital stimulus the sound of the voice that brings language, sets thoughts astir, and keeps us in the intellectual company of man.”¹

Language “contingently” focally embodied in sound forms the inter-subjective “opening” to the World in terms of the linguistic core of language. Two qualifications concerning this assertion should be preliminarily noted: first, the claim is, not to be taken to mean that a loss of the auditory dimension makes “thinking” impossible; this is clearly false, but that the loss of the focal capacities of the auditory dimension displaces the “contingent” focus of thought, although thought continues to be embodied in different ways. Empirically it has long been recognized that the problems of deafness are essentially tied to the problems of language, and that such a relation poses the most serious problem for those afflicted. Second, there is at least a weak sense in which, unlike blindness, there is never a case of *total* deafness. The gradations of hearing shade off into a larger sense of one’s body in listening. The ears may be focal “organs” of hearing,

but one listens with his whole body. The folk music fan “hears” the bass in his belly and through his feet, and the deaf child learns to “hear” music through his hands and fingers. There is, usually, some extremely vestigial hearing in the deaf that can also be partly extended through intensive amplification. But the deaf person continues to “hear” in an essentially different way from the ordinary listener in that what to the ordinary listener remains a fringe effect—sounds felt and experienced in the body—is sometimes the entirety of the deaf person’s auditory “focus”: he “hears” from *only* the fringe.

Not only does this close off the “contingent” *focal* intersubjective language of humankind, it also effects the way in which he “hears” himself. When I speak I also listen to myself. I feel and take for granted the sounds which I hear returning from my voice. This also gives me a sense of how correctly I may be projecting or enunciating.

But it may be that I fail to notice, until provided with the auditory mirror of a tape recorder, that I do not hear myself as others hear me, neither do they hear me as I hear myself. When I speak, if I attend to the entire bodily sense of speaking, I feel my voice resonate throughout at least the upper part of my body. I feel my whole head “sounding” in what I take to be sonic resonance. This self-resonance that I take for granted does not appear on the tape, and I am initially surprised at the “thinness” and the “higher tone” my voice has on the recording. Physically, of course, not only can these effects be measured indicating the effect of my voice on my skeletal and muscular framework. I hear through bone conduction as well as through the acoustical properties of the air, but the two “media” of self-hearing are essentially separate. There is an essential sense in which *my hearing of myself is distinct from all other forms of hearing*. The same is the case in the presence of my “inner voice,” which “thinks” in a language.

Chapter 11

Inner Speech

The familiar but elusive character of inner speech as an imaginative modal counterpart to spoken voice calls for its own establishing variations. Some preliminary qualifications, however, are also appropriate. First, it is clearly not the case that all thinking is “linguistic.” There are many important and clearly nonlinguistic aspects to the full range of thought. There is, for example, a kind of visual thinking that is possible particularly in the arts, in design, and in certain kinds of geometrical thought. Neither do I contend here that an auditory “linguistic thinking” is in some way necessary to the learning of language as such, because there may be “languages” in other dimensions of experience. In this sense the auditory form of “linguistic thinking” is “contingent.” When language occurs in other dimensions of experience, it remains *embodied* (sensuous) language and is molded according to the dimension in which it occurs. Yet within the “contingency” of inner speech as the normative form of “linguistic thinking” the role of an almost constant self-presence carries important clues concerning the role of thought and its relationship with myself and the World.

Naive reflections are perfectly familiar with inner speech as the phenomenon of thinking in a language. Yet in spite of this easily recognized type of thinking there remains a hiddenness and elusiveness to ongoing inner speech. The first reason for such elusiveness is common to all reflective phenomena that deal with intentional aspects. The very intentional referentiality of experience points away from itself toward that to which

the intentional reference points. The very structure of an intentional involvement with the World that also obtains for inner speech hides this form of experience itself. Were this not so, intentionality would “get in the way of” the projects and goals that are fulfilled or frustrated in daily life. Inner speech that accompanies these activities does not intrude itself into them but recedes as a peculiar kind of background phenomenon that provides a continuity and a “sense” to such activities. The very familiarity of thinking in a language conceals its shape.

There is a second and related reason for this elusiveness. As a type of *language* inner speech hides itself for a second time. Language, insofar as it functions to “let be” or allow *otherness* to show itself also does not call attention to itself in ordinary speech. Words do not draw attention to themselves but to the intended things in referring. This extends ordinarily even to the form of embodiment in which the language is found. Thus in speaking, what is ordinarily focal is “what I am talking about” rather than the singing of the speech as a textured auditory appearance. This is not to say that the singing of speech is absent; it is present but as background that does not ordinarily call attention to itself.

The tendency to miss the sonorous quality of speech is related to the tendency to forget backgrounds and to abstractly believe that one can attend to a thing-in-itself. This peculiar and often highly functional background does, however, present itself in dramaturgical forms of speech such as those found in rhetoric, poetry and chanting, and the actor’s voice. In such cases even while there continues to be a “showing through” the spoken language, the embodiment of that language in sound is more keenly noticeable.

The third reason for the hiddenness of inner speech lies in its own way of being self-present which is essentially different from other forms of auditory imagination. But its analogue is locatable in voiced speech. Inner speech is to the full range of auditory imaginative noetic acts as voiced speech is to the full range of auditory perceiving noetic acts. A special series of variations which locates this style of self-presence is called for.

I “hear” inner speech differently than I “hear” other forms of auditory imagination. From the previous variations it is quite apparent that an auditory imaginative presentification of an other’s voice may be made. But this presentification is distinctly different from that of inner speech. It is an imaginative “listening” to an *other* which I may recall, fantasize, or spontaneously remember. And when such an occurrence is underway, my own inner speech as the almost continuous self-presence of thinking in a language either momentarily recedes or ceases altogether. That is not what thinking in a language shows itself to be.

But when I turn to inner speech itself, although I recognize clearly that it does not appear as “like” the voice of another, I find it hard to grasp directly. I “catch it” from the fringe; it seems to evade objectification. Only with effort and in a sense indirectly do I gradually entice its significance. It does not come to “stand before” me the way in which the other’s voice—or even my own voice as quasi-objectified—occurs. In these struggles, however, the indirect “glances” of inner speech begin to release certain aspects of the phenomenon. Inner speech is active, ongoing in its elusiveness, and it seems to be “nowhere” or “everywhere” when noted. This “linguistic thinking” does not present itself as coming from “somewhere” but retains its elusive self-presence as either background or accompaniment to the remainder of what I may be engaged in. In this, too, it carries the significance of not being “other,” but rather of being *my* thinking.

Here inner speech, though more elusive than voiced speech, retains some isomorphism with spoken voice which also presents itself as coming not from elsewhere. Rather, my voice in its self-presence is felt bodily. Furthermore, as an *active* constitution inner speech retains the same sense of “mineness” as voiced speech. A countervariation indirectly points up this significance. Were my inner speech suddenly to become confused and appear to come from elsewhere (as apparently happens in some cases of schizophrenia) I would be startled and confused. In such a case the alienation of inner speech that turns it into an imagined rather than an actively imagining voice bespeaks a deeper division of the self that now no longer “hears” itself properly. Inner speech that is thinking in a language is self-present as “my” thinking self-presence in contrast to other forms of auditory imagination that presentify otherness.

If inner speech is marked by the intimate sense of *my active* thinking, it is also quite concretely a thinking *in* a language. Again, while the subtleties of this phenomenon are elusive, that one thinks in a quite concrete language has been noted often and easily enough. It is particularly notable to those who have “entered” more than one language and recognize that to think in one language as compared to another alters the “style” of thought significantly.

I ask myself, In *what* language am I thinking? And, ordinarily, the answer will be English. Although without the question I may have been only implicitly aware of this, my thinking tends to float back to its mother tongue. This may be noted in the extremities of countervariations that attempt to break this weighted centrality of the mother tongue. I imagine “trying” to think in Russian, a tongue that is opaque to me. Perhaps a few words occur, *nyet, da*, but they reveal little. Then perhaps I “cheat” as in the movies, speaking with a guttural accent; but the thinking is then only

distorted English. Or perhaps I bring to mind a thinking in “noises,” but here there is no thinking in a language at all.

I turn to German, which is readable to me although conversationally difficult, and as soon as I attempt to think *in* the modulations of that language I soon find that the weightedness of the mother tongue is obvious as a type of “inner translating” quickly shows itself as the mediation of thinking in a language. Only when I turn to French do I recall those moments where there is an absence of even inner translation. Dreams, conversations, and lectures are experienced in French and I begin to know what thinking in *another* language is like. Here I think in a language with a markedly different style than that of my ordinary thinking in English. But no sooner do I begin to genuinely think in that other language (after the years of struggle in which only approximations of it are made), than it, like my native English, begins to show itself in a transparency that hides its singing.

In the process of entering a second or third language, however, there is an instructive experience. I have to purposely exert an effort both to listen to and to form the words. In such instances the “sounding” of inner speech under effort contrasts vividly with the case of being in a familiar and thus transparent language.

This very ease of thinking in a language in inner speech hides its phenomenological characteristics. But so, too, do the “speed” and modulations of inner speech. Inner speech does not show itself a word at a time any more than does my voiced speaking. It bursts forth in rapid totalities that present themselves as an uneven “flow.” And unless attended to specifically it may be hard to recount just what words have been used at all. One does not attend to words as such but to a larger “singing” of phrases and sentences.

Moreover, these may not show themselves as well-formed sentences at all; inner speech is “colloquial” and “conversational.” It “jumps” and “changes key” almost constantly. I rather doubt that even philosophers “think” in the argued jargon that appears in their journals. Stream-of-consciousness writers, attentive to such phenomena, although still reconstructing inner speech, better display this flow and associative “play” of the interior. The style of inner speech is not that of finished writing. It does not have the polished, reflective “time” of words that come to stand on the page.

Although this speed and irregularity of inner speech is reflectively available, it may also be approximated in a comparison with other language speeds. If I attend a lecture, assuming I am neither a speed writer nor a trained stenographer, I find that in taking notes of what the lecturer says, I write down not a verbatim account but a bare suggestive outline. His actually spoken lecture is far “richer” than the few notes that have “reduced”

his saying to a skeleton. Similarly, when I am speaking to an other, my thinking inner speech may be racing, running ahead of my verbal speech such that I always seem to have far more in mind than I am able to voice in such occasions, and this is in part due to the relative *speed* of inner speech. There is no translation here of unworded thought into worded thought, although there may be the transformation of a speeded and running ahead of inner speech into a slower and more deliberate voiced word.

Inner speech, actively constituted, speedy, and colloquial, peculiar in its appearance as “mine,” also approaches a near continuity of self-presence in ordinary thinking. But this continuity is a vascillating continuity that oscillates between the *filling* of thought, as in the concentrated thinking on some problem, and the barely if at all detected “*accompaniment*” of other activities, as in athletic concentration.

Neither is the continuity absolute, although it remains a familiar focus within thinking activity. The events that disturb thinking in a language are preliminarily instructive in this respect. I have already noted the disruptive capacity of sounds to interrupt this continuity. The intrusive power of sound to penetrate even ordinary self-presence also disrupts inner speech. But within the realm of the interior I also find that *auditory* replacements display peculiar resistances to inner speech.

As I “think,” I decide to presentify a strain of imagined music, but as I do so I discover that my inner speech momentarily ceases, “turns off,” or else it resumes in a series of alternations in the interstices of the imagined sound. I try to think in a language and at the same time imagine the previously imagined melody, and again I come upon the resistance.

Yet when I visually presentify the sailing yacht I desire to myself, I find no resistance to the simultaneous commentary on that yacht in the form of inner speech. Inner speech as a “voice” may accompany the dimensional multiplicities of imaginative experience, but it meets certain resistances in the auditory dimension.

I push the variations further. In imagining a melody I find I can “insert” rapid bursts of thinking in a language in the alternations and interstices which occur in the rapid inner time that is experienced, but the melody and the “voice” of inner speech war with each other for presence and self-presence. I begin to imagine the presence of others who speak in the cacophony of a cocktail party, and here, some times and fleetingly, “my” voice seems to join theirs in a chorus. But careful attention soon shows that when this occurs “my” voice has also undergone a transformation, it has become momentarily objectified from the nowhere-everywhere of inner speech and has become “objectified” as a voice of an other. “I” have become a “quasi-other.”

In such glimpses of the auditory manifestation of inner speech as thinking in a language, its auditory embodiment and its intimacy as self-presence shows itself. Its near continuity as an almost constant copresence with “outer” experiencing, however subdued as background accompaniment, points to further significations of inner speech. The *familiar* and taken-for-granted character of my inner speech functions to maintain a certain familiarity within the environment. The voice of language domesticates the World.

I begin to explore a new territory, perhaps a beach in a strange land. Suddenly I come upon a creature I have never seen before. I am surprised and momentarily *speechless*, both in the sense of not saying anything and that of uttering a short cry. But also “interiorly” I note a brief interruption in the activity of my “thinking self.” As I begin to follow the creature with my eyes, at first puzzled with the question, What is *that*? the momentary strangeness is gradually replaced by movements which begin to relate the creature to similar forms of life which I have seen elsewhere. The commentary of the meaningful, even though not yet successful in this instance, begins to refamiliarize the experience. Speech again begins to pervade in copresence the ongoing experience in the World.

This disruption of the familiar is recaptured once inner speech resumes its accompaniment to “outer” experience. But at the same time, the thing has been *named*, however superficially or metaphorically: “Ah, that is like a ——.” Inner speech as thinking in a language “permits” this continuous and familiar way of moving in the World to return. Inner speech, it may be noted, performs *as* language. It is language which names, which familiarizes, which fits something into a scheme and thereby domesticates it. But *as* language, inner speech is the self-presence of language.

It is here that inner speech, a most “interior” phenomenon, may be understood to be intimately related to the most “universal” of the significations of language as intersubjectivity. I live in the presence and the self-presence of language. Inner speech as *a modal core* of imaginative auditory experience echoes the voice of language in the World. Its polyphonus self-presence is in tune with the sounded presence of the World. This self-presence is, in its core modality, no more quiet than the sound of the World. Its life sounds in word.

This polyphony of inner and outer voices, however, is not always an equal polyphony. Speech flits in its main melodies between the inner and outer voices. At one moment speech and the self are present *in* the explosive expression. In a moment of anger I shout, “You bastard!” and, although I may recover my composure in the next moment, at its occurrence my

angry intention was authentically expressed in speech. Or, in a moment of delirious joy the triteness of "It's beautiful!" may be the appropriate expression of speech.

In dissemblance or in double meanings, however, a partial polyphony of speech may be experienced. In the disharmony of deceit what I say hides what I think. I think of how I despise another and feel the sense of satisfaction gained from successfully fooling him. Or in a moment of seduction the ambiguous phrase carries with it the intense desire that it be taken as an invitation to further meetings. Here the doubled voice may be discerned on the fringes of the experience of language.

A fully doubled voice is subject to the alternations of concentrated attention. A "divided attention" shows itself as weighted toward one of its focuses. I walk along, mindlessly humming a ditty, all the while thinking in inner speech. Yet once noted reflectively, the discernment of the rapid alternation of the onset of the humming tones followed by the onset of "thoughts" shows itself. Here the near distance of inner and outer soundings show a difference of a wordless musical humming and worded thought.

I try another variation and speak out loud while at the same time maintaining inner speech. Here the sense of competing resistances reaches an extreme. Bursts of thought now clearly occur in the interstices of the words or disappear altogether as I become engaged in the speaking. Or else the actual speaking itself becomes mindless or repetitive while the thinking inner speech carries the weight of significance. The same alternation may be noted in the thinking ahead which occurs when I formulate an answer while already speaking the answer. There is a resistance to the complete simultaneity of inner and outer speech.

For attention to be divided there must be a distance. Within the realm of the auditory a minimal distance for such a division is that between worded and unworded or musical sound. The mindless ditty, the hum, the mouthed phrase allows a partial polyphony at the fringe. But in the region of the word a massive resistance blocks a full duet of the expressing, speaking self. Even the music of the ditty is a partial resistance.

Much easier is the division of attention which allows one to look about, perhaps scanning the paintings in a gallery, while at the same time he is absorbed in a line of thought. True, one is not letting the pictures show themselves in fullness, but after the tour one can easily describe both what one has seen and what one has thought. The apparent "autonomy" of sight implicates its distance from inner speech. There is a sense in which inner speech "allows" the dimension of sight to stand alone before one. The

intrusion of the auditory is, conversely, an index to the central role of the auditory in inner speech.

In this respect auditory imagination “lets be” a visual “world.” My inner speech does not strongly intrude on what is seen, and the “objectivity” of the seen resides partly in this permission granted by the meaningful accompaniment of ongoing experience. Word resides in myself in such a way that language “lets be” a World as a significant phenomenon.

Part IV

Voice

This page intentionally left blank.

Chapter 12

The Center of Language

Listening to the voices of the World, listening to the “inner” sounds of the imaginative mode, spans a wide range of auditory phenomena. Yet all sounds are in a broad sense “voices,” the voices of things, of others, of the gods, and of myself. In this broad sense one may speak of the voices of significant sound as the “voices of language.” At least this broad sense may be suggestive in contrast to those philosophies and forms of thought that seek to reduce sounds to bare sounds or to mere acoustic tokens of an abstract listening that fails to hear the *otherness* revealed by voice. A phenomenology of sound and voice moves in the opposite direction, toward full significance, toward a listening to the *voiced* character of the sounds of the World.

But there is also a danger of misunderstanding if the idea of language is extended that broadly without qualification. Not only does such an extension risk making everything (and thus nothing) into language, but it places itself in a position of ultimately denying a connection with the philosophies of language and of mind that sometimes secretly share the concerns of a phenomenology of listening and voice. Thus if the extension of the idea of language is taken symptomatically to point up the continuity of all the potentially significant aspects of the voices of the World, then a further distinction must be made that specifically distinguishes the “linguistic” form of language from “language” as the significant. “Linguistic” language *is language-as-word*. It is the *center* but not the entirety of language in the broad sense.

There is some phenomenological precedence for making such a tactical distinction and characterization of language-as-signification and language-as-word. From the outset the “unit” of meaning in phenomenology is experiential rather than “merely” linguistic. To speak, to understand, and to perceive are *meaning-acts*. But what is heard, understood, and perceived—within the realm of human being—is also taken as already pregnant with meaning. Furthermore, the intentional structure of human-World correlations already shows that there is a kind of functional isomorphism involved in all meaning-acts, and thus, as Ricoeur says, meaning or significance is already *both* perception *and* word.

Admittedly, this tactical distinction blurs the difference between perception and language in favor of meaning-acts, but this blurring is also already latent in phenomenology from the outset. Moreover, this blurring is also addressed to phenomenology in its later forms. To elevate the importance of language is not meant to demean perception which has been the first and often dominant theme of recent phenomenology, but it is meant to purposely move away from the still recalcitrant vestigial “empiricism” within phenomenology. This vestigial empiricism is a matter of a certain interpretation of the levels of experience and of a seeking for origins, often in mythical pasts. There is here a rejection of lost and forgotten pasts, of “prelinguistic” levels of meaning in favor of a beginning that is better characterized as *starting in the midst of* that which is already here, the already constituted. That is a “beginning” from the center.

The notion of a center, however, calls for a preliminary and general location. Center partly, but only partly, relates to the previously developed notion of a *focal core* within some dimension or the totality of global experience. The center of language as language-as-word may be understood as similar to the appearance of a focus-fringe phenomenon in the sense that deployed around language-as-word is a vast field of meaningful activities which may in the broader sense of language be called “languages.” These “languages” are gravitationally weighted toward the central significance in word, but they may be relatively distinguished from the “linguistic” form of language.

There is thus a “language” of gesture which can itself be rich and highly significant in its expressibility. Without spoken word Marcel Marceau can mime into existence an entire context that is “silently” understood. The other’s *face*, particularly, “speaks” a silent “language” in the smile, the frown, the slight tinge of sadness, or the massive blankness of mourning. This is language-as-significant, but without word. There is also a “language” of actual touch which belongs to gesture. In intimacy the “language” of touch conveys an often greater intensity of intersubjective communication than a word may seem to convey. But after the intimate, beyond the gesture, lan-

guage-as-word returns as the weighted center of significance, and the daily traffic of voiced speech and listening resumes its functional centrality.

As a center, language-as-word can also be *decentered*. Thus it is not to be understood as a fixed focal core. The “languages” of gesture and touch may in fact become the focal cores within a duration of ongoing experience, placing language-as-word momentarily to the side. Yet there is the “inner” reassertion that insists on resuming its role even in the presence of an “exterior” silence, as in the case of my thinking in a language that may accompany a reverie. There is sometimes a hiddenness to the center.

Insofar as language-as-word is the center of language, it never stands alone within the range of the significant. Again, like the notion of focal-fringe structures, the center of language presents itself only in the midst of a wider significance. Word does not stand alone but is present in a field of deployed meaning in which it is situated. In this sense there are always other significations along with word. This is the *copresence* of word and wider signification. Here other possibilities emerge, possibilities of the overwhelming complexity and richness of the broad sense of language that threaten to subdue the search for structures and invariants and point to the essentially *open* horizon of language. What is said always carries with it what is present as unsaid. In the copresence of language-as-word centered within the field of language as the significant there is a range of variations which indicate that “too much” is being said.

At one extreme there may indeed be a harmony in the saying that brings the unsaid significance into a united meaning-act. The child’s laughing voice reverberates harmoniously with the look of her smiling face when she receives a gift. But at another extreme there are variations between the said and the unsaid that equally hold the possibilities of dissimulation. He smiles as he speaks, but his unkindness shows darkly through his words in the touch of sarcasm revealed. Here, only he who listens well can detect these subtleties that do not always float on the surface of the words. And he who does not or cannot listen deeply may hear only the words. Further still lies the dissimulation that allows what is spoken to be given the lie by what is thought in a disharmonious copresence of “inner” and “outer” speech.

A complete topography of language would thus have to deal not only with the lateral relations of its center in the saying to the gesticulatory and contextually surrounding field of significance but also with the depth of relations between the “outward” center of language-as-word and the possibilities of the range of harmony to disharmony among the polyphonies of the human voice. Within this complexity of the relations of language-as-word lie the essential ambiguities of actual speech and life. Thus, too, the experience of language when considered in contexts wider than technically

restricted “languages” reveals itself as containing a degree of existential uncertainty and revocability within the ordinary speech of humankind. To listen and to understand mean more than the comprehension of words, they signify entry into a wider communication situation.

However, the dominant problem here is not the examination of an entire philosophy of language nor even the possibilities of existential language. Rather, the dominant problem lies in the auditory dimension, *voice*. Language comes alive in word, but within the “contingency” of human word there also may be seen a functional centrality to *voiced word*. *Language-as-word is normatively embodied in sound and voice*. If the center of language is language-as-word, that center shows itself in the ongoing traffic of human interchange “first” and dominantly in the auditory dimension. Its significance is *a meaning-in-sound*.

Here, in fact, we meet two problems. First, if language-as-word is the focal center of the languages of the world and the self, those languages are phenomenologically understood to be existentially *embodied* languages. This is to say, with Merleau-Ponty, that the word has a meaning, or, better, the word *is a meaning*. In either case it is the actual, concrete word, the sounded word that is the meaning. In this respect phenomenology remains thoroughly “anti-Cartesian.” Its “linguistics” must also be “anti-Cartesian linguistics.”

Meaning *in sound* embodies language. But it is not the only embodiment of language. Nor is it even the only embodiment of language-as-word. This is because there is also a possible second decentering of language-as-word in terms of different embodiments of language. Historically, of course, the most important form of second decentering has been that of spoken word by written word. And although there are minor gesticulatory languages which also decenter the auditory word (as in the case of codified and conventionalized sign languages), the appearance of writing remains the primary “second” embodiment of language-as-word. This possibility constitutes the second problem in the understanding of the role and the importance of voiced language as the normative center of language.

Moreover, these two problems cross in resisting the potential overthrow of “Cartesian linguistics” for the sake of an emergent comprehension of phenomenologically embodied language or existential language. The phenomenology of language finds its justification in the *absence* of fulfillable nonembodied meanings. Where meanings are found, they are found already embodied, although the variations on embodiment are complex. The word is sounded, seen, felt; and even in thought its presence takes its own “shape,” whether in inner speech or in the soundless presences of other dimensions of the imaginative process.

But there are two preliminary directions in distinguishing embodied language from its “Cartesian” lineage. The first direction is that of a movement toward the fulfillable experience of language which is simultaneously a movement away from hypothesized “disembodied” meanings. In the auditory dimension this is the movement that reflects on the presence of listening.

The first direction is that of a temptation to accept as heard the posited “abstractions” of Cartesian metaphysics. When I listen to an other I hear him speaking. It is not a series of phonemes or morphemes which I hear, because to “hear” these I must break up his speech, I must listen “away” from what he is saying. My experiential listening stands in the near distance of language that is at one and the same time *the other speaking* in his voice. *I hear what he is saying*, and in this listening we are both presented with the penetrating presence of voiced language which is “between” and “in” both of us.

A “Cartesian linguistics” however, does not hear. It supposes its listening to hear “bare sounds,” “acoustic tokens,” which in an undiscovered “translation” are mysteriously or arbitrarily united with the disembodied and elusive “meanings.” These meanings float above and beyond the embodiment that is what presents itself to listening. Experientially just as the thing is always already found as the “unity” of its “qualities,” so in language is the word always found already embodied and significant.

But to listen with a phenomenological “naïveté” is by no means simple. The infection of a “dualism” of the “body” of language in abstract sounds with its presumed disembodied “soul” of meanings pervades our very understanding of listening. This linguistic dualism constantly tempts the listener to hear what is not heard. Thus to more fully locate the fullness of voiced word there is a need to take note of the near and far reaches of sounded significance that remain “outside” language-as-word. On the near side there remains the enigma of musical presence, a sounded significance which is nonlinguistic. On the far side there remains the enigma of the horizon of silence that situates, surrounds, and permeates the presence of word.

If the first temptation of a “Cartesian linguistics” is the dualism that leads to an abstract listening that is no listening, the second temptation is to see in other embodiments of language-as-word an alternative that relativizes the spoken word and relegates it to a mere “contingency.” Ordinarily, in literate cultures, humans are adept at two embodiments of language-as-word, the spoken and the written word. But just as there are differences of arrangement within the dimensions of perception and imagination, there are also differences in the double embodiments of language-as-word. The *shapes* of the focal-field arrangements in voiced and written language are not perfectly isomorphic in their characteristics. There is a difference in the mode of presence regarding significance.

If I write the word *Adam* alone on a page its context remains opaque. For the reader who comes on the word on a page, the field and its unsaid significance is a dark obscurity. Perhaps, if I am a philosopher, I surmise that this is a “bare name.” But if this word is *spoken*, there is already a certain potential field and presence of unsaid significance in the voice. If “Adam” is said in an angry voice, imploringly, or in a quiet whisper, each sounded presence allows the “bare word” to emerge from some of its obscurity in the sounding of its presence.

This is not to say that the “same” context and presence of the unsaid could not be elicited in written language-as-word. But in that case there is also a significant difference in the mode of presence in which the context and the unsaid occurs. I can, as I have done above, fill in the opaqueness by adding more words. I can surround *Adam* with the context I wish if I am skillful in my writing. I can write “Adam” to be said with staged direction, imploringly and thus suggest the sounded word context that I hear immediately in the spoken word.

However, in both the versions of a word in context there has been an embodiment in sound or in that which is sighted. Without embodiment the “meaning” does not occur, but with embodiment there is a difference in the “sameness” of meaning as a phenomenon. It is here that the usual meaning of “reducing” speech to writing occurs. The written word “lacks” the sounded significance that already gives a degree of context to the word, and this makes the unsaid less opaque. Writing fails to convey that minimal sense, although the “reduction” can be compensated for by adding words that also soundlessly replace, in their own way, what was lost. Writing creates the possibility of a *word without voice*. It opens the way to the forms of unvoiced word which secretly dominate whole areas of the understanding of language. Husserl foresaw this relationship in his article, “Origin of Geometry,” insofar as he discerned that the higher reaches of mathematizing thought (as more advanced forms of “voiceless” language) are in fact dependent on the emergence of writing.

Humans have not always recognized the possibilities of voiceless language. The fourth-century student who came upon Ambrose reading in the scriptorium *without saving the words* was amazed at “silent” reading. Nor does everyone, even today, read without the noticeable presence of outwardly silent but inwardly “sounded” words. There is here a continuum between voice, voiced reading, inner voice only with reading, and voiceless reading. Yet even voiceless reading can subtly reestablish its secret liaison with the adherence of the spoken word when the phenomenon of “hearing” a friend in the book that he has written occurs.

The secret adherence of speaking to writing remains in the learning of reading as well. The realm of written language-as-word is entered as a "second language" after a person has already entered the realm of speaking. At first the words are "sounded out," and the reader learns a written language as slowly and as simply as he did first speech. But once having entered the second embodiment, word without voice becomes possible. This possibility is also one which moves further and further away from the liaison with voiced word.

At its most suggestive and descriptive, as in the novel or the poem, writing still reflects and elicits a sense of the auditory. The characters of the novel breathe and feel and speak, and the imagery of writing allows the sensory adherence of life to show itself. But in the language of the report, of the newspaper, the account, no voice emerges; or if there is voice it is personless as the "everyman" of Heidegger's *das Mann*. Without voice the *per-sona* recedes, and there is the possibility of "depersonalization."

The unvoiced word of written language, however, is but a first existential possibility of decentered word. A second movement is also possible in the heart of unvoiced word, and that is the step toward both *unvoiced* and *wordless* "language." Further from speech lies the realm of the voiceless and wordless "languages" of logic and mathematics. The first decentering of language-as-word that eliminates the voice of the other opens the way to a second possibility that eliminates the word itself. But the word may be eliminated only by embodying "language" differently, in the abstract symbol or the number that now replaces word but remains embodied in its own mode of presence.

There is born in the graded possibilities opened by the "second language" of writing a progression toward "languages" that are *distant* from language-as-word. But this distance is deceptive, because the movement away from the center also retains a relation back to the center. For even as the new pathway of thinking opens there remains a weighted center of gravity from which the pathway moves. The thought which takes its flight from voice and word remains situated in relation to the thinking-speaking that is "ordinary" language.

Not only do the logician and mathematician return, for their ordinary affairs, to the region of spoken word, but the "metalanguage" that situates and surrounds the flight from voiced word itself remains the forgotten, implicit context from which the flight takes place. When I, thinking as a linguist, "objectify" language and posit it as a system of sentential structures with "grammars" whatever their surface or depth; or when I, thinking as a logician, follow the deductive movements of a wordless calculation, I also find already present and embodied that thinking in my mother tongue that

floats among my other thoughts. My “objectifications” relate back to and presuppose a living language within which I already stand.

If this is the movement that is opened by the decentering of voiced word on behalf of written word, there is also the countermovement in the opposite direction. Just as there are voiceless words, there are wordless voices, the voices of things which are a wordless speaking. Such voices are pregnant with significance but not yet word. Thus I recognize the voice of the truck that sounds differently than the car, or the voice of the neighbor’s dog that barks differently than the occasional harbor seal, which also “barks.” The voice of each thing bespeaks something of its *per-sona*.

Here lie possibilities of another extension from the center of language, perhaps not so fully developed as the first flight away from voiced word. There are anticipations of these possibilities in the ordinary “understandings” which occur, for example, between humans and animals. My dog “understands” something from my speech: she knows her name, even when it is spelled (which she has learned to recognize). And in the new sciences there is hope of “understanding” dolphin or whale “language” sometime in the future.

But in this direction often lie only the projections of our worded voices extending to speechless things a certain hearing of speech where there is no word. If awaiting a guest in the summer, the wind and more particularly the “babbling” brook carry sounded voices for my keen anticipations. Try as I may, I do not succeed in eliminating these occasional “voices” in the “babble.”

In this direction lies the seduction of the *musical* which is near language-as-word. Music embodies significance in sound, but it is the sounded counterpart to the wordless “languages” which arise out of the possibilities of written language-as-word.

In the history of phenomenology it has been Merleau-Ponty above all who has pointed to the intimacy of language and music. To speak is first to “sing the world,” he affirmed. And in the nearness of music to language, the incarnation of “meaning” in sound seemed most clear in the case of music where there can be little doubt that the meaning *is* the sound. Merleau-Ponty found even the apparent opacity of music to be closer to language than it is usually thought to be, for the “grammar” of a musical piece fails to yield the “transparency” of language only in its self-containedness. The sediments of the conventional do not so easily transform themselves in music as such.

But some music, while “close” to voiced language and “closer” than other forms of the wordless, remains wordless. The dark mystery of music shows itself differently, and the listening that it calls on is not the center of voiced language-as-word. Music in its nearness to the center helps locate the center.

Chapter 13

Music and Word

In all music, sound draws attention to itself. This is particularly the case in wordless music, music that is not sung. Here the “meaning” does not lurk elsewhere, but it is *in* the sounding of the music. There is even a sense in which the listening that music calls for is a different listening than that called for by word. Wordless music, in its sonorous incarnation, when compared to language is “opaque,” as nothing is shown through the music. The music presents itself; it is a dense embodied presence.

It is this *immediacy* of music that Kierkegaard described as the “pure sensuous,” the “demonic.” But there is no “purity” to the sensuous, it is rather a matter of the pregnancy of meaning that presents itself as music. Only when compared to language, the center presupposed long before being called a center, does music appear as a “dark mystery.” Nor, for the same reason, can music be thought of as “abstract”; there is more than a surface to the sound.

Phenomenologically the question is one of listening reflectively to what occurs, to how music is presented if the pregnant significance is to be detected. If music in its unworded form does not “refer” to the world, if it is not characterized as a “transparency,” its mode of presence must be located otherwise. But in this, music is not different from other sound presences, although it accentuates and emphasizes possibilities in its own unique way. Its “reference” is not things, but it enlivens one’s own body. To listen is to be dramatically engaged in a bodily listening that “participates”

in the movement of the music. It is from this possibility that the “demonic” qualities of music arise.

In concentrated listening its enchantment plays on the full range of self-presence and calls on one to *dance*. Dance, however, must be understood not merely in a literal fashion, for dance in this context is the enticement to bodily listening. Thus the full range of the dance to which music issues a call is one that spans the continuum from actual dancing, as in dance music or in the spontaneous dances found in rock festivals or religious revivals, to the “internal” dance of rhythms and movements felt bodily while quietly listening to baroque music.

It is in the call to dance that a different reason for the Cartesian temptation to conceive of sound as a “body” emerges. If, on the one hand, music is sound calling attention to itself, the temptation then is to conceive of music as “pure body”; but on the other hand the call to dance *does* engage *my* body. But what occurs in this engagement is clearly anti-Cartesian. It is my subject-body, my experiencing body, which is engaged, and no longer is it a case of a deistic distance of “mind” to “body.” The call to dance is such that *involvement* and *participation* become the mode of being-in the musical situation. The “darkness” of music is in the *loss of distance* which occurs in dramatically sounded musical presence.

Not only is one’s bodily sense engaged, but the previously noted *filling* of auditory space occurs as well. The now dramatic sounding encompasses and penetrates listening. This filling of auditory space is the loss of distance, of an open space to listening. It is a form of musical ecstasy which is at the other end of the possibilities of “objectification.” Music *amplifies* a participative sense of bodily involvement in its call to the dance.

But such dramaturgy of musical sound is not absent from any other experienced listening, although it may be withdrawn and minimal. If I return to the realm of word, I can detect similar losses of distance in the filling of significant auditory space. His angry shout can electrify me, and I feel the threat in his tone. Her whisper is an enticement that sounds irresistible. In sound presence there is always this possibility. In spoken word there is *a dramaturgy of voice* which is essentially musical. Music amplifies the dramaturgy of sound.

If music is thus used to locate an aspect of voice, in the realm of word this musical presence may be heard, not as absent, but in a different way. Ordinarily we think of speech as primarily a matter of communication, of a “transparency” toward something that is not itself speech. This is not always the case. There is, in the learning of language, a “transparency” of a language already learned. The Vietnamese language sounds tinkling and bell-like even if what is being said is a curse. I recognize in German a

singing that, before I enter the “transparency” that only gradually occurs, is a musical phrasing more like that of English than that of the French tongue. The foreign tongue is first a kind of music before it becomes a language; it is first pregnant with meaning before the meaning is delivered to me.

Inversely, there is an analogous sense in which music also has a “grammar” and a style. No one mistakes the Rolling Stones for Mozart, neither do the more learned mistake Handel for Haydn. Yet all of these musical “grammars” are closer together than the strange “grammar” of gliding, complex, and stylized pieces of Indian music which to the beginner first often appear as not even “music.” The sounding of sympathetic strings and the use of twenty-two microtones, the whine of sitar and sarangi, present musical confusion. Yet once learned, Indian music proves to be one of the most highly classified, organized, and hardened musical traditions in musical history.

These approximations, however, do not yet precisely describe the nearness of music and word. The “music” of language and the “grammar” of music remain caught in a metaphysical classification. There is a sense in which, phenomenologically, spoken language is at least as “musical” as it is “logical,” and if we have separated sound from meaning, then two distinct directions of inquiry are opened and opposed. But in voiced word music and logic are incarnate. No “pure” music nor “pure” meaning may be found.

Yet, except in clearly dramaturgical situations, the sounding of word does not call attention to the sounding as music does. In ordinary speech the sounding of word remains in the background. This is not unimportant. The vibrantly expressive speaker is usually thought to be more interesting than the dull speaker. The difference is sounded. The strong voice commands where the thin and wispy voice does not. Yet the sounding withdraws as the context and setting in which *what is said* emerges as foreground.

Here the “darkness” of the musical yields to a “transparency” of a particular type. It is the “transparency” that is located in the *enabling power* of word. Sound in word “lets be” what is not sounded. A return to an artificial approximation in a “Wittgensteinian” example may begin the establishing variations.

Suppose first in a “Wittgensteinian” language situation that meanings must appear as words, but that these meaning-appearances also must be visual. In such a case, then, as I walk down the street I might come across a sycamore tree, but it would have no meaning for me unless its appearance occurred with a word. Thus as I look at the tree suddenly a translucent “word” would appear in front of the tree, and the tree would be properly “named.” But in this case the translucent “word” would also intrude itself between my seeing the tree and my recognizing the tree as tree.

But now suppose that the embodiment of the word-meaning could occur in sound. This time when the sycamore tree appears I look at it and hear the name *sycamore tree*. In this instance the tree may continue to stand before me undisturbed while it receives its meaning in the sounded word. The sound-meaning does not disturb its visual presence but lets its visual presence be.

The example is overly simple. In ordinary experience it is clear that every time I see something I recognize I do *not* say to myself, "Ah, that is a sycamore tree." Although I could do this, and in cases of doubt or ambiguity I may indeed begin an inner monologue, what the example does begin to indicate is that the possibility of a near distance is opened between an embodiment of meaning and that to which it "refers." If the "referent" is in the same experiential dimension as the embodied meaning, one might be led to expect the resistances of doubled sameness that I noted previously.

An objection, still in the context of the overly simplified "Wittgensteinian" example, can also occur. If the role of sounded language is to "let be" the visual appearance, then would not one also expect meaning embodied in sound to pose a similar problem to listening? The answer is, of course, that such is indeed the case, but it is the case in terms of polyphony. In genuine listening to another in a conversation I must let him speak, I must resist both speaking and allowing my own inner speech to intrude. Within the polyphony of the spoken and inner speech, if I begin to think along my own line of interest while he is speaking, I find that his speech recedes and that I have to reconstruct it from the fringes of the auditory dimension: "What was that you were saying?"

Between the visual appearance of the tree in the approximation and the sounded inner speech there is a *difference* that may be called a near distance. In this distance there is a clue for the lack of attention that often occurs in the philosophy of language to such phenomena.

The role of sound does not point to but away from itself, "allowing" what is *seen* to stand out. Language-as-word, unlike music, even while sounding, does not draw attention to itself *as* sound. And yet, were the other to be speaking, and suddenly the sound actually disappear, I should no longer be able to hear what was being said. The "transparency" of his speaking would not merely be diminished but disappear as explicit. What was being said in the sound retreats and becomes opaque, but significance does not disappear entirely. It is transformed to the vague and implicit significance that I can *see*. In watching the silent spectacle of his speech I see that "something" is being said.

Here a second oversimplification in the example emerges. In its present form it implicitly denies significance to the visual elements of the

approximation. When I meet a friend I do not spontaneously say to myself, "Aha, there's Bob," although I may do so if I wish. I do not need to "say" this to myself, because Bob's visual presence is already significant though neither expressed nor situated in a line of thought. When, however, he enters the conversation, then the alternation of polyphony and of central signification as word returns to its normative position.

The possible dialogue that can then commence displays a series of complex possibilities regarding the modalities of sounding presence. Ideally, perhaps, he speaks, and I am silent both vocally and inwardly as I listen to his voice. Then the opposite occurs when I speak. I am "in" my voice, and there is no echo from the inner polyphony that I can master. But there is also the possibility of only partly hearing what he says as in the case of an intrusive inner speech, and the same possibility applies to his listening. But in each case the degree of intrusion is in terms of the added sound presences that occur in the communication situation in relation to language-as-word. In the dimension of sound the situation of an intrusion of the same order does occur. The enabling power of word occurs in the midst of the fragility of polyphonous sound.

Music locates the function and role of the center of language in a second way. Music draws attention to sound, but its sound is a transformed "created" sound. In this sense its sound is *strange*. Its sounds are not those of unattended things nor those of spoken voice, although music shares intentionality with human voices. To an extent this strangeness of music applies even to the contemporary experiments which seek to escape "composed" or "constructed" sounds. The music that is a *mélange* of "natural" sounds draws attention to the musical character of all sound (I have already noted this aspect). The aim is a transformation of listening, a listening to the music of the World.

Ultimately, however, such a listening does away with the idea of music as such, for then music is not distinct from sounding in any appearance. As "set apart" however, music retains a certain strangeness. Each new piece, each melodic gestalt, provides a "new language." We do not listen to music all day, its time is "set aside" as a special time.

In contrast, the presence of word is *familiar*, and its sounding is that of a familiarizing continuity, particularly in the ongoing self-presence of inner speech.

But there are times when this familiarizing continuity is broken. A most dramatic occurrence is shock. A phenomenology of shock would show that during the moment that shock is incurred there is a suspension and disruption of the familiar in an extreme way. What ordinarily appears as stable, understandable, and structured at the moment of shock becomes disorganized, chaotic, fluid, and lacking in the hierarchies of value and

meaning experienced as the ordinary. Shock occurs as an *absence* of familiar word, and talk may be needed afterward as a therapy of recovery.

Less extremely, the strangeness that may occur in the *absence* of word may be shown in deliberately constructed experiments. I ask my students to do variations on the exercise, "Try not to think of a white bear." Each case is a deliberate attempt to "turn off" inner speech as linguistic thinking. This results in several outstanding occurrences. First, there is a certain difficulty in deliberately "turning off" inner speech that indirectly demonstrates its familiar but nonobtrusive self-presence. But with effort and imagination, ways may be found to accomplish the "turn-off." Some of these have been noted as the interruptions to the flow of inner speech.

A second step is then called for and the experimenter is asked to attend carefully to the momentary appearances of things in the interstice when inner speech is silenced. Again the response is quite uniform: in the moments when this occurs things become unfamiliar and strange. The descriptions that result often include terms such as "more vibrant," "alive," "unstable," and even "uncanny." These descriptions, when the presence is one of animals or of persons, sometimes mention a sense of "power" or a feeling of "fear." Familiarity is displaced, and strangeness is found to be lurking within the very nearness of things in the absence of word.

These descriptions, however, are not unknown to philosophy, even if they are extraordinary for descriptions of things, animals, or persons. They are, rather, closer to the classic descriptions of intense aesthetic, religious, and mystical experiences recorded in the history of thought. These are usually thought of as exceptional experiences, but in the cases mentioned above what was exceptional was enticed by a purposeful thought-experiment.

Phenomenologically, it is more appropriate to term such experiences *horizontal*. They are experiences that "stretch" ordinary experience to limits. The wordless presence of strangeness indirectly shows the more ordinary function of familiarization that the presence and self-presence of word allows. Inversely, the revelation of strangeness lurking within the presence of things, which is ordinarily concealed by familiarity points to the need to develop further the relation of horizontal phenomena to the center of language.

The absence of word in momentary occurrences elicits the significance of the horizon as *silence*. Silence is in some sense a limit of language-as-word, a limit that constantly withdraws from the center. Word is present, but as situated within a wider field of signification it reaches outward to the ultimately silent horizon. Within the ordinary the horizon hides itself, but at the limits the horizon has its own way of revealing itself.

Chapter 14

Silence and Word

The horizon as silence situates and surrounds the center. This is the meaning of horizon as first outlined in the approximations of the auditory dimension. In this respect the horizon at its extremity first shows itself (indirectly and at the extreme fringe) as *limit* which trails off into the *nothingness* of absence. As extreme limit the horizon constantly withdraws and hides itself, yet it is that which situates the entirety of presence itself. Horizon as limit and horizon as the Open is thus the extreme degree of possible description.

There is, however, a third significance for horizontal phenomena that is closer but more hidden, which must be drawn upon for its role in further locating word as center. This is the horizon as the unsaid, the latently present; horizon in the midst of presence as the hidden depth of presence. To return to modeled approximations that elicit this sense of the horizon, a return to perception may be made. Things show themselves as “faces” but never as mere “faces.” They are situated and hide within themselves as latently significant another side. This is a significance which I implicitly recognize and expect: I am not surprised when the block is turned around and it shows a different “face.” The thing presents itself as having a back, as having a depth. This may be spoken of as a local or latently present horizontal feature of the thing. It is the hidden side of presence which is enigmatically “in” presence.

Again the approximation has been primarily a visual one, so the next step is to locate the same feature auditorily and, in the present context, in terms of word. The voiced word, however, also shows itself as having a

hidden depth, a latently meant aspect. This is concealed within but detectable in listening to language. In everything *said* there is the latent horizon of the *unsaid*, which situates the said. Yet, as in all horizontal phenomena, the horizon is that which withdraws. It is easily overlooked or forgotten. Easy or naive listening attends only to the center, but in doing so the latent meaning of the horizon remains taken for granted and its latent meaning situates the saying by its unsaying.

The variations which begin to elicit the significance of the unsaid cover a series of horizontal phenomena. The broadest horizontal feature regarding the unsaid as latent significance is the feature of the *unspoken context* which surrounds speech. The context belongs to a degree of silence. Here the variations that most pointedly mark the horizontal role may begin in situations of opaque contexts. If I begin to speak to the other in terms of *halyards*, *sheets*, *gybing*, or *bending on a line*, the listener who has not yet heard the “language” of sailing may return a blank, puzzled stare. I have said something to him, but he has not heard in my saying all that is to be heard. Similarly, in the midst of the tribe of philosophers, if I begin to make these notes on the board, $p \supset q$ or $p \vee q$, the instant recognition by the initiated of the wordless “words” of symbolic logic may appear to be perfectly transparent, but to the uninitiated they would be perfectly opaque. In each case there is a border of the unsaid which, until entered, hides the saying itself. In these cases the language also hides in implicitness but is silently heard or not heard in the saying.

The silence of the context, however, is not a blank nor total silence, it is the near silence of what *can be said*. In this the example is similar to the visual example of the latent “face” of the thing. I can turn the thing around and view its other “faces” and see only a relative degree of hiddenness at any one time. There is always some “face” or other that is hidden—the *ratio* is an invariant structure—but I can get any “face” I wish. The same is the case with the low horizontal degree of a near context. This degree of the unsaid may be obtained and heard.

But it is also important to note *how* such a degree of the unsaid may be heard. Its silence is one that implies that in some sense what was not said explicitly *has already been said*. While not all can be said in a saying (there remains *a ratio* to the unsaid which is the transcendence of the context) what was not said has been said in *a community* with a *history*. Existentially implied in the context is some kind of tribe, or community with a history. Learning to hear the unsaid gains entry into this community and history to some degree. The learned is the initiate who has already heard and thus has entered into the community and the history.

There are technical “tribal languages” whose sayings hover near ordinary speech, but in which there are highly determined meanings that are heard only by the initiate and not by the ordinary listener. The unsaid can be missed in unlearned listening.

I wander through the mazes of the university seeking those technical “languages” that deal with auditory experience. I chance upon a lecture in acoustical physics. I listen. The lecturer speaks in English, and the words he utters seem familiar. He speaks of *acoustical reflection*, of *plane reflection*, of *parabolic reflection*, of *elliptical reflection*. Yet although the words are ordinary, their significance does not appear as immediately obvious to the stranger. Lurking at their fringes lie the yet unknown regions of the unsaid, the silence of the presuppositions, and the framework of definition that gathers the saying. There is a certain strangeness to the words. But once the massive unsaid is heard, and one returns to the saying, its obscurity vanishes, and there is a clear, light, and present meaning to the terms. To know a sentence entails knowing a language. This also implicates the community that speaks the “language.” To enter the language is to enter a form of life.

The learner must undergo a catechism of definitions and relations in the technical “language.” He gradually learns to speak like a member of the “tribe,” and in the process the significance of the word becomes intuitive, for he has learned to hear the echoing and reverberating horizontal significance of the unsaid.

The communities and histories that carry variations of the unsaid are multiple and complex. There are “languages” which are also distant to ordinary speech. I enter a church where there is a prayer service. I listen, and the ritual is seemingly in English, but its tone is archaic. I hear spoken *Thee* and *Thou* and perhaps even a reference to “thynges that go bumpe in the nyghte.” I am mystified, and the significance which lurks in the ancient words escapes me. But if I become an initiate the unsaid is gradually unfolded. I begin to hear a reverberation from ancient times and from the silence of the past there begins to spring a certain life. Adam, Abraham, and Amos begin to live in pregnant significance. I listen again to the ritual and begin to discern the regioning horizon as no longer opaque but as the echo of the past into the present. For the ritual tongue ties humankind to that which has gone before him. Even, indeed, if the ritual has transformed itself into the “timeless” distance of that which occurred *in ille tempore* as in the ahistorical forms of religions. The days of the gods are to be repeated and remembered, and the ritual spans this distance in its dramaturgy.

In both cases, that of a technical language linked to a scientific community and history and that of a ritual language linked to a religious

community and history, there is displayed a ratio of the said to the unsaid. And for both there is a moment in which forgetting this ratio becomes possible. Word does not stand alone but stands in a ratio to the unsaid, the immanent horizon that proximally situates the saying. But the initiated listener can so take what has been said for granted that the clarity and obviousness of what is now said tempts him to forget that this clarity and obviousness has been attained by longer listening. And in his temptation the "truth" of his tribal language is thought to be "timeless." The surface hides a depth.

Not all depths are, however, ratios to the traditions of tribal languages as such. Within the complexities of speech lie also polyphonus significances that are possibilities of the ratio of the said to the unsaid. I am a lover courting my beloved, but we are still partly strangers. What I say on the surface is ambiguous; it is an invitation to share a more intimate liaison, but it is masked in such a way that should she refuse me I may retain my composure. Or I am a politician, and the surface of my words conceals more than it reveals. But the careful listener who knows this language of purposeful ambiguity detects in the slight change in wording the sign of a change in position. Here one listens "beneath" the words, his intention is to hear "below" the surface, and there, guarded but understandable, is the language of the unsaid.

The varieties and complexity of the ratio of the said to the unsaid are indefinitely large in number, and a comprehensive hermeneutics of language would have to address these varieties. For my purpose here, however, it is sufficient to note the nearness of significant silence as a proximal horizontal feature. The listener hears more than surface in listening to word. The clarity or opacity that he discerns in the saying remains in part dependent on the learning to listen which probes beneath surfaces, which hears the interior of speech.

But the ratio of the said to the unsaid extends further than the near proximity of the context and of the depth of the saying. Horizon was first noted as extreme, as limit, and as the Open beyond the present fringe of presence itself. But the further reaches of horizontal significance are not without relation to the proximal horizon. There are occurrences when in word there may be heard an intimation of a wider limit. Such is *poetic word*. Poetic word elicits a new context. It brings to saying what has not yet been said. There is here a sense of violence to word in that the poetic saying disrupts the clarity of the sedimented unsaid.

Poetic word, however, is not merely the novel word. The new word, the creative or poetic word, is not necessarily a word which appears for the first time in the vocabulary of humankind. Perhaps it rarely is. It is rather a word

or saying which *opens* experience precisely toward the mystery of the silent horizon as the Open. That which says the horizon is that word which spans the horizon, thus it may be new and old simultaneously. The “linguistic analysis” practiced by Heidegger is often an example of spanning horizons. The methodology, which simultaneously “inquires backward” into the very roots of Western thought, into Heraclitus and Parmenides, and also opens and creates meanings in ancient words that were not at all clear there to begin with is a poetizing thought at the horizon.

The sample of *Dasein* in such analysis is sufficient to suggest the possibility of a wider saying. In its ordinary context, *Dasein* is what is thought of as an ordinary existent or thing. But in Heidegger’s thought *Dasein* becomes *Da-sein* the “being-here” that I am. “Being” as an active experiencing and “here” as the finite position which I occupy are my *Da-sein* in a way more significant than the mere “being-there” of an inert object. By opening the word to a wider and deeper context, the word becomes “poetic” in the sense of a bringing-into-being of a meaning; but at the same time it is a bringing-into-being of a meaning that I almost “knew all the time.” Philosophical poetizing is such an opening of language-as-word. It is making silence speak. The silence is the horizon, and the word opens toward the horizon. Such is the wider opening which allows significance to be gathered more profoundly.

Is all of this too much to find in the reverberation of the voice? The question of the horizon of silence was posed, as was the question of music, to locate the centrality of word in voice. Ordinary speech, although it potentially contains the richness of the unsaid, in its very ordinariness allows what is hidden to “float” lazily in the midst of its words. Yet even in gossip there lurks the ratio of the said to the unsaid. The possibilities of silence are vast. However, it is in extraordinary voice, the dramaturgical voice, that sounded significance can be amplified. United in a single saying are the “Cartesian” realms of sound and meaning.

This page intentionally left blank.

Chapter 15

Dramaturgical Voice

Voice sounds, but its possibilities are not always amplified clearly. In dramaturgical voice, however, the sounding of voice is amplified. Dramaturgical voice stands between the enchantment of music, which can wordlessly draw us into the sound so deeply that the sound overwhelms us, and the conversation of ordinary speech, which gives way to a trivial transparency that hides its sounded significance. In dramaturgical voice there is united in the same moment the fullness of sound and of significance as a paradigm of embodied word.

The dramaturgical voice amplifies the musical “effect” of speech. This heightens the significance of the word that has been spoken. In the *saying* of dramaturgical voice there is *dabar*, or “*word-event*.” This word-event is an occasion of significance that is elevated above the ordinary. A dramatic presence, precisely in the context of being in its set aside, in its elevation over the ordinary, allows what is implicit in all speech to emerge more clearly.

Dramaturgical voice occurs in drama. With the ancient Greeks theater remained quasi religious. Here the voice of the actor emerged from the mask, or *per-sona*. Not only was the individual human face masked or transformed and set aside from the ordinary in a stylized form, but the voice was also masked, transformed, becoming the voice of a god or a dramatic hero.

So, too, does dramaturgical voice occur in ritual or liturgy. The liturgical voice said in the mass, the prayer, and the litany is a transformed voice. The speaker is elevated in minaret, pulpit, and altar; and the extraordinary

voice of the cantor or the cardinal speaks in tones that elicit the gods and the saints of the historical community of humans.

Dramaturgical voice also occurs in recited poetry. The celebration of language that emerges in the reading of the poem, the epic, or the legend is another amplification and setting apart from the ordinary which, in turn, renews and enlivens the ordinary. It may be in a voice of protest, as when the voice through poetry asserts the freedom that a regime attempts to still. Or it may be in the simple celebration of a barely noticed aspect of nature, when the poet recites a simple haiku.

In each form dramaturgical voice reveals the possibilities of voice, of voiced language-as-word. Philosophy, however, has often harbored a suspicion of dramaturgical voice. There lies within dramaturgical voice a potential *power* that is also elevated above the ordinary powers of voice. Rhetoric, theater, religion, poetry, have all employed the dramaturgical. The dramaturgical voice persuades, transforms, and arouses humankind in its amplified sonorous significance. Yet from the beginning there is the call to *listen* to the *logos*, and the *logos* is first a discourse. This discourse spans the realm of (auditory) word from the most inner silences of conscience to the uppermost reaches of dramaturgy. Comprehensive listening calls for a listening to the dramatic as well as to the quieter forms of discourse.

But there is another reason to inquire about the dramaturgical voice today. It is the *voice* of dramaturgy which remains at the center of spoken language-as-word. Reason, which at times becomes “voice-less,” carries hidden within it a temptation to create a type of disembodiment that becomes a special kind of tyranny forgetful of the human, forgetful of the existential position of humankind. Voiceless, wordless reason becomes the property of an elite whose technical tyranny becomes a threat as great as that of the ancient rhetorician. A reassertion of the role of voice becomes a reassertion of the essential intersubjectivity of humankind as being-in-language.

A phenomenology of the voice is in this sense not only a return to the center of embodied meaning in sound but a return to the existential voice, to the speaking and listening that occurs with humankind. In the voice of embodied significance lies the *what of* the saying, the *who* of the saying, and the *I* to whom something is said and who may also speak in the saying. In the voice is harbored the full richness of human signification.

Thus, not only is there the constant possibility of polyphony in the realm of voiced word, there is also the possibility of a harmonious or disharmonious gestalt in any occurrence of word. Here there is a counterpart within sounded word that reverses the first approximations of sound and sight in relation to the experience of language-as-word. In a panoramic view of the visual field

there is an all-at-once quality to the experience. Within the view lies a multiplicity of things united spatially in a gestalt. But in reading, there is a certain “seriality” or “linearity”; writing occurs in a line, and to read is to follow the series. (Speed-reading, of course, takes larger gestalts into consideration, but the “linearity” remains in that the order remains important to comprehension.) In listening to voiced word, however, there is a different type of all-at-once gestalt which, although also serial in a strictly temporal sense, is a gestalt in which the harmonics or disharmonics of voice occur. The “meanings” that are more than merely grammatical ones occur within this all-at-onceness giving dramaturgical voice, in particular, its amplified sense of possibility.

To return to a single example, this harmonics of saying revolves around the at least doubled significance that lies in *what is* said and in *how* it is said. The “bare word,” “Adam,” here may have as its substitute the simple saying, “I hit the wrong nail!” The amateur carpenter knows all too well the significance of this exclamation, but the voiced word with its bellow of rage contains in its all-at-onceness the sounded significance which exceeds a “bare” exclamation. There is a doubled “grammar” in the sounding, with its “inflections,” “intonation,” “accent,” and “stress,” which is the singing of the tongue in its full expressivity. This “grammar” sounded in the *how*, co-present with the *what*, of the saying is also part of the voiced tongue.

The obviousness of doubled significance finds heightened awareness in the listening that is amplified, and is trained to the nuances that ordinary listening does not detect. Thus if the philosopher’s listening is particularly acute for the declarative or the argumentative, not all listening is so constituted. There is another listening and speaking that attends to the “grammar” of a different dimension of embodied sound in voice.

THE ACTOR

The actor is such a listener. His ear is selectively tuned precisely to that dimension of voice that utters the *how* in which the saying occurs. His listening as well as his speaking is dramaturgical, and his ear, tuned to those modulations that are already preunderstood among humankind, reflects and amplifies this language of multiple “grammars.”

In his apprenticeship he learns to incarnate anger and sorrow, tenderness and pathos. As he learns he notes the multiple ways in which the harsh anger of the shout that electrifies the audience can also give way to the soft whisper of simmering hatred in which the threat of wrath is quite palpable. His voice fills the stage with amplified sounded signification.

His listening is in a sense a purposeful decentering of precisely those things to which the philosopher bends his own ear. The actor's preference for *voicing* is what allows his voice to bring to life the wider context of meaning which animates the drama. Nor is this voicing without its structure. The audience understands in its listening the modulations of the voice which it hears. They are "absorbed by" and "enter into" the sounding words that present the human situation in comedy and tragedy. Here is the embodiment of sounded signification beyond what is merely declarative in which a whole range of unsuspected existential possibilities may come to life.

In dramaturgical voice the transformed and amplified possibilities of sounded significance show forth. The musical qualities of voice are enhanced. This is particularly apparent in the voices of a chorus in which the rhythm, the chantlike repetitions of sounds present a mood as in the chorus of women in T. S. Eliot's "Murder in the Cathedral."

Here is no continuing city, here is no abiding stay.
 Ill the wind, ill the time, uncertain the profit, certain the danger.
 O late late late, late is the time, late too late, and rotten the year;
 Evil the wind, and bitter the sea, and grey
 the sky, grey grey *grey*. . . .¹

The building repetitions of "late late late" and "grey grey grey" paint a sounded background of somberness and anxious foreboding in the voice of the chorus. Against this background the foreground speech of the single character stands out having been given the depth of the overall mood-tone. The chorus is the "continua" of the drama in such instances; the character's voices are the "solo," and drama is the full "music" of voices.

Drama is not only an assemblage of characters with individual voices but a totality that is "symphonic" in its orchestration. Even when there is a "single" character, as in *Krapp's Last Tape*, there is a minimal symphonic harmony to the monologue of time and tone in the voice on the tape. *What is said*, the discursive, in voice is never present alone but is amplified within the possibilities of *how* the voice says it.

In this, however, the dramaturgical voice amplifies the possibilities of voice, but its reverberations strike a response that is prepared. The tonalities of voice are foreknown in the listening and the voices of humankind. There may even be a sense in which the tonalities of felt sound are "universal" in a wider sense than the tongue of a particular language-as-word. Crying, moaning, the curse or threat, and certain kinds of singing convey a wider significance that overlaps with the amplification of dramaturgical voice and is foreknown by communities of humans beyond the boundaries of particular tongues.

If what is said is *in* sound which is simultaneously significant in the how of saying, *who* does the saying is also copresent in voice. Here dramaturgical voice reveals a complexity within the *per-sona* of voice. The sounding voice is both a penetration into my self-presence and the presence of *otherness*. But dramaturgical voice raises the question of which other. The actor speaks in a role, and the voice he speaks may in some sense be the voice of another. Oedipus and Hamlet appear, and the actor as an individual recedes. A dialectics of the self and the other appears in the very presence of the drama.

But the self and the other are not on the same plane. The actor's voice does not obliterate the self. There is a style to his voice which remains his own even while the other emerges into the foreground. I still recognize Richard Burton or Lee Marvin or Bob Dylan in the voice of the amplified other who is present as the dramaturgical character. Yet the drama also *transforms* the voice in its amplification: it is not a "mere" Burton or Marvin or Dylan who appears, but the character in the voice of the actor.

In this dialectic of amplified voice lie the possibilities of "bad faith" in roles that Jean-Paul Sartre has often described. The continuum of sameness to otherness that allows us to enact roles belongs also to voice. But the dialectic is not without recognizable structured aspects. His individual style of voice determines to some degree the range of roles an actor may play. One cannot cast a thin, effeminate voice into a male heavy role without some other factors taking effect. But the style of individual voice relates far more to deeper aspects of voiced language. In voice there is something of personal history and situation as well. When I speak I reveal something about my origin, my situation within living language. The Southerner who both hears and says *pin* and *pen* with the same pronunciation lives in speech in a way that is different from those with New England accents.

Neither does the loss or transformation of such accents diminish the significance of one's being in speech. The loss through effort or the acquired loss typical of mobile contemporaries is also significant in that the situation within speech is also changed. The cosmopolitan "general" accent bespeaks a different situation in speech. There is an essential significance to my style of speaking situated in its relation to language-as-word. In Pygmalion fashion, to change one's speech implies a greater change, a change of self. Indeed, the rapid and willful ability to transform voice and its situation within speech takes its own form among the community of actors. To "become" another in voice with ease opens the way to a certain self-becoming that may, and often does, emerge either as a self-doubt reflexive toward one's self, or an ease that masks or, better, allows for the making of an extraordinary flexible character to which others fail to find ordinary stability adhering.

Yet every voice is also trans-individual. The style which adheres to a role is transcended in the role in which otherness may appear. The adaption of an accent not mine, the transformation from twentieth-century America to sixteenth-century England is a possibility of dramaturgical voice presence. Yet a personal history and style is not discontinuous with the trans-individual in voiced word. Language-as-word is not private or individual as such but is intersubjective from the outset. This is also revealed in speech, for in speaking I always show more in saying than myself alone.

Dramaturgical voice plays within the intersubjective possibilities of language. Otherness shows itself in the roles and “voices” of Falstaff and Everyman, but such possibilities are inherent in the voices of language from the beginning. This multiplicity is threatening to a concern with an “authentic” voice, which at base is a concern with a *single* voice. The demand that the innermost voice be the same as the outermost voice, that only one role ever be played, harbors a secret metaphysical desire for eternity and timelessness.

Dramaturgical voice does not display the difference between appearance and reality so much as it does the multiple possibilities of every voice transformed from ordinary to extraordinary. The “others” who appear are the human possibilities that are also “my” possibilities, and the drama is a “universal” play of the existential possibilities of humankind. But the drama is the extraordinary in the sense that in the set-aside time of the stage the existential-imaginative possibilities portrayed there are not bounded by the single life I have to live. The drama is an exercise in imaginative variations that portrays the range of possibilities open to humanity but not to a single individual who is temporally bound and limited. The elevation of humanity in its full complexity thus makes us aware of the *tristesse* of finitude. The catharsis is also the recognition that the play does *not go* on forever.

Dramaturgical voice also amplifies the previously noted phenomenon of the auditory *aura* of the presence of the other. The actor amplifies the sounding voice, he *projects* voice into the recesses of the theater. This resonant voice is an auditory aura that im-presses in sound. The auditor is not merely metaphorically im-pressed, but in the perception of the other in voice he experiences the embodiment of the, other as one who fills the auditorium with his presence.

Yet what is most dramatic in the projecting, resonant voice from the stage is also present in the experience of the other in ordinary discourse. The other is more than an outline-body. In speech and the experience of voice there adheres an enriched experience of the other. The person with a strong voice is impressive in a way that the person with a weak voice is not. Contrast the stage presence of the accomplished actor with dramaturgical vocal power against that of the small child in a school pageant. The falter-

ing lines, the uncertain quaver, the lack of resonance and projection bespeak the dependency and childlikeness of the actor. Much of the charm of the pageant, although best appreciated by the parents, lies precisely in the pathos of the not yet fully matured voices of the small children.

In the voice of the actor, the drama of the other comes to presence. But the other is bound to me as well. We both stand and take our speech *within* sounding language. Sounded language surrounds and penetrates the recesses of the self and the other. The dramaturgical voice amplifies and displays these variations on the modes of being in language.

THE LITURGIST

What I have written of the dramaturgical voice of the actor may also be applied to other dramaturgical forms. But if the actor learns to personify the other, particularly the other human, the liturgist emphasizes another possibility of voice. He bespeaks tradition and the voices of the gods. They sound in his voice. In the West, with its religion of Word, the sound of dramaturgical voice is particularly marked. The marks that have been added to the Torah, to the written form of the tongue, which has vowels in speech but none in writing, reflect the ancient tradition of the synagogue in which the Word must be correctly canted. "Hear, O Israel" is voiced in the event of the liturgy and in a traditional and stylized sound.

The liturgical voice also reads the Gospel, setting it apart from ordinary discourse by the saying, "Thus beginneth the lesson." The moment of the elevation of the host is also the moment of setting apart in the sound of chime or bell. Even the sects which claim to have dispensed with liturgy retain a stylized dramaturgy of voice. The repetitious but dramatic voice of the Pentacostal preacher sounds a call for repentance similar to the muezzin's older stylized call to prayer in Islam.

Liturgical voice is in certain ways less flexible than the dramaturgical voice, but that is because its transformation of voice echoes a more distant type of saying, a highly traditionalized otherness. In liturgical voice there are echoes of the ancient past. Matthew, Mark, Luke, and John; Abraham, Isaac, and Moses speak in the liturgy. But the ultimate otherness of liturgical voice is the echo of the gods.

There is particularly in Western religions a theology of *Word*, where God himself is the *God of Word*. God *speaks* and the world comes into being. In Christianity Jesus is the *Logos*, or Word. The Holy Spirit in *filling* the congregation creates a unity of spirit, a unity of the *tongue*. The presence of Word is central to Western theology.

More subtly, the very experience of the God of the biblical traditions is an experience of word in voice such that the person of God is “like” an intense auditory experience. The Western God of Word gradually became known as an omnipresent but *invisible* God. In the ancient Hebrew traditions it became totally prohibited to *represent* God in an image. To “image” God was to create an idol; but while saying the name of YHWH was also prohibited, there was no prohibition of the “speech” of God being “represented” in the written word. God’s Word must be remembered, engraved on the heart. The invisible God was not absent, but *present* in Word. When he was absent it was when he *refused to speak*.

But omnipresent, invisible presence is presence of sound in its most dramatic moments. The liturgist fills the synagogue with sounding voice. And in the classical religious experience of Isaiah in the Temple, vision is obscured as the temple is filled with the smoke of the offering, but the voice of God presents itself in the very midst of the visual obscurity.² The God of voice surrounds, penetrates, and fills the worshiper.

The God of voice, of Word, is also “personal,” for the voice bespeaks a per-sona. The anthropomorphic quality of the arguments between God and Abraham, the covenant between God and his Chosen People bespeak the incessant discourse between men and gods. In a theology of Word both men and gods belong to a conversation.

There is also in the theology of Word a distinctly temporal-historical dimension. Word is *dabar*, which is both “word” and “event.” God’s speaking is an event that is itself an act. The willfulness of the Western God is the temporality of his speech-act, the manifestation of the God of historical moments. The making of those words “come to stand” in the Torah and the Bible is the temporal-historical equivalent of stability, of “essence,” but with a difference. Word is to be repeated, to be remembered, to be reenacted in the liturgical event. The Feast of Tabernacles, the Last Supper, the days of the liturgical calendar are at base reaffirmations of the historical.

The essentially invisible presence, the surrounding and penetrating presence, the temporal-historical presence of Word, of holy voice is also a *dominantly auditory presence* within the heart of Western theology. This God cannot be coerced but must be “let be,” for he speaks or “shows” himself in Word only when he will, just as sound occurs when it will. Such a God is dramaturgical voice in the extreme even if the voice at times must be heard as the “still small voice” that sounds silently after the thunder and the hurricane.

In the drama of the liturgy the god is experienced *in* the presence of voice. But the listening which no longer hears *in* voice the sounding of the

god cannot at will draw speech from the silence. The god is the ultimate extreme of otherness that nevertheless belongs to the same possibilities as sameness in the presence of word.

THE POET

In its most ancient form, poetry was spoken, recited in a singing of verse. There was the recitation of an epic, the singing of a ballad, the extended storytelling in the form of verse. The music and rhythm of poetry retains its adherence to the spoken word, for poetry is “close” to music as a form of dramaturgical voice. In one respect, the poetic voice is the most flexible of voices. Its range extends to the liturgical in the psalm and the theatrical in epic. But more than giving presence to the voices of others and of gods, poetic voice extends to things. In poetic voice there resounds a “speech” of rocks, mountains, and sky; of machines and jugs and other voices of the world.

Even in written form poetry retains its adherence to the sensuousness of sound. It is the sounded significance that sings in the mystery of a beast portrayed by Blake:

Tyger! Tyger! burning bright
 In the Forests of the night,
 What immortal hand or eye
 Could frame thy fearful symeetry?³

And although sound is more explicitly mentioned in Frost’s “Sound of the Trees,” its adherence to the word is one that elicits the sounding of trees.

I wonder about the trees.
 Why do we wish to hear
 Forever the noise of these
 More than another noise
 So close to our dwelling place?
 We suffer them by the day
 Till we lose all measure of pace,
 And fixity in our joys,
 And acquire a listening air. . . .⁴

But although not lacking in any form of well-developed dramaturgical voice, the voices of poetry perhaps make more apparent a certain

sparseness of speech that reveals another side to being in language. Poetry amplifies silence. In a directly elicited sense of silence in poetic utterance there is the haiku:

I heard the bird
in the valley
and suddenly
realized the silence.⁵

Here, the sensuous richness of experience is elicited in few words. I “hear” in the poem the call of jay or crow over the mountains, and in the call and its echoes I realize the surrounding silence that allows the call to “stand out.” The call is indeed more stark and vivid in such sparseness of expression.

This suggestive simplicity may, of course, be noted in specific forms of voice. The radio drama recalls nostalgically for many a sense of richness of imagination often lacking in more explicit audiovisual presentations. A contemporary illustration is the Stoppard *Artist Descending a Staircase* in which sound alone conjures the context, suggesting and making imaginatively present the absent global quality of experience. In more traditionally stylized form the very meager or even silent quality of the Noh drama of Japan elicits the richness of silence that is not empty but filled possibility.

The descriptive and enabling power of the poetic is in each of these cases “richer” than many forms of direct or extended analytic description. In the poetic voice a “gestalt” occurs that engages the hidden horizontal significance of that which is present in the speaking. The poetic voice “allows” the horizon to be “given,” to “e-vent” itself in and around the words. Here I write of the poetic *experience* prior to any possible analysis of the “mechanisms” or “techniques” that a metaphysics of poetry seeks to discover.

The word of poetry enables otherness to be vividly present, even that hidden significance that emerges in horizontal significations. The elicited and suggested “noema” of that which appears is of course strictly correlated with the “noesis” of the listening act. The poem calls for its own form of listening which is, as in every listening, enriched by both the wealth of the listener’s own experience and the ease with which the poem may be “let be” in its significant presence.

Dramaturgical voice amplifies the possibilities of sounded significance throughout the full range of human voice. The gods, things, and others gain voice, and all are situated within the silence which is the horizontal limit of sound. This extended amplification displays the conversation which is humankind.

Chapter 16

The Face, Voice, and Silence

In the very midst of the conversation that is humankind there are beginnings. But not all beginnings belong to the center of language-as-word. There are beginnings that occur before and after speech. If I meet an other who is a stranger who may not speak my tongue, then the meeting is one that takes place within “language” only in the broader sense of language as significance. Here, decentered from the focal, clear meaning of word, I meet the other as *face*. But the face, too, belongs in its own way to the *play of the polyphonic* that exists at the heart of voiced language-as-word. To meet the other as face includes the possibility of conversation. The face in its signification bespeaks, in relation to the center, the pregnant nearness of significant silence.

From attending to the heightened amplifications of dramaturgical voice, I return to the ordinary affairs of daily life. Perhaps I am engaged deeply in some absorbing project, and I fail to hear the other enter the room. I suddenly see him and look at him face to face. He has broken the solitude, and on such an abrupt occasion there may indeed be something like the “internal hemorrhage” that Sartre describes when my “world” bleeds away under the gaze of the other.¹ In the face-to-face meeting, however, this “hemorrhage” is brief, and the shock generated by the other gives way to an *invitation to word*. This is so even if the word is perfunctory. Face-to-face meeting without any word results in awkward silence, because in the meeting there is issued a call to speak.

What follows, of course, is variable in relation to the degree of mutuality between us. If, on the one hand, the other is a salesman who intrudes not only bodily, but with mock intimacy in his voice and too soon uses my familiar name and too soon “violently” presumes mutuality, I may retreat or reject his call. If, on the other hand, the other is my friend, the conversation begins by already presupposing the long history of what has been said previously, and the brief ritual greeting gives way to discourse that moves easily and freely. And if the other is my beloved, then the conversation that has already occurred over a long period is deepened by the richness of the unsaid, and a sparse economy of words conveys more than another party could hear. The pregnant silence of the unsaid allows the horizon of significance to carry the burden of the conversation in its greater ratio to the saying.

In each of these cases the presence of the other as face carries both the significance of pregnant silence and of a call to speech and listening. The silent call of the face may give way to spoken word, which then presents itself with all the surrounding, penetrating power of sound in a call that insists that I “obey” by responding. The ancient meaning of *obaudire*, “to listen from below or from the depths,” echoes in the call. The other exceeds the silent presence of the face in the aura that has been cast and places both of us in the midst of mutually penetrating sound.

This meeting that gives way to conversation however, is not simple but primordially complex. It takes place not only in the “dialectics” of the face and the voice, but it echoes the *play of polyphony* that sets the limits for existential possibilities. Only ideally and rarely do I attend so solely to the other that the full mutuality of being-in the fullness of language may occur. Equally, I may retreat into myself and the self-presence of my inner speech whose “static” closes off some of the call of the other. Every conversation cannot only mask itself in the ambiguities of word, in the ratio of the said to the unsaid, but it can flit among the possibilities of the polyphony of voices we are. Thus the meeting is fragile.

There may be a sense in which philosophy, ever seeking the stable and “eternally” secure, detects and resents this fragility. Perhaps it is even implicitly aware of the polyphony. Philosophy has often resisted recognizing polyphony as primary. Philosophy’s desire and aim has been for a *single voice*, identical “within” and “without,” which harbors no hidden side of unsaying or of countersaying.² In its visual metaphors its goal has been a pure light or transparency; auditorily its goal is a sound which does not harbor a relation to the silences which conceal a hidden dimension to every sound. But the single “authentic” voice occurs only in certain privileged moments. Those are the moments of fragile meeting in which there is an exchange of concentrated listening and speaking. There remains, though,

an important point in relation to the primordially of polyphony that sometimes escapes the philosophical traditions that have also harbored deep suspicions concerning voice. The very possibility of an essentially “doubled” voice is a possibility that holds that every “expression” also hides something that remains hidden and thus cannot be made “pure.”

This remains the case even for the ideal moments of genuine speaking and listening. The speech situation occurs within the context of full significance. Here not only voice but the face as the indicator of pregnant silence remains part of the entire gestalt. This is the *nearest* horizontal aspect that surrounds the central speech. But there also remains the hiddenness of the “silent” voice of inner speech which, like the hidden side of a transcendent thing, remains hidden to the other. And beyond both the pregnant silence bespoken by the face and the “outer” silence that does not reveal inner speech, there lies the *Open* silence of the ultimate horizon. In all three of these respects there remains a hiddenness that belongs to the center of voiced language. The perfectly “transparent” eludes the desire of philosophy.

To the seeker for “transparency” the hiddenness appears as a weakness, a barrier within language; and the dream of overcoming polyphony takes the form of overcoming the Tower of Babel. But this dream itself harbors its own type of darkness, not knowing that the Tower is itself more expressive of the human situation than its hidden presumption of innocence, which lies on the other side of existence. The dark desire of the dream emerges from time to time in the very strategies that seek to make absolute the totally transparent. Sometimes these take the form of various reductionist attacks on language.

The attempt to clarify, noble in itself, can contain a desire to control. This control, however, is at the same time an attempt to overcome the finitude of the play of presence—hiding that occurs in voiced language-as-word. To combat this play various “therapies” are invented that seek to reform, to remake, to transform language in a direction that lies distant to the latent richness of existential polyphony. The symptoms may be seen in the science-fiction nightmares of rationality gone mad. These take the form of *forcing* polyphony into monophonic single speech. The ultimate control of language would, in a sense, be a powerful weapon in controlling thought were it not in part due to the constant possibility of its escape within polyphony. The fantasies of spy stories in which chemically induced “truth” pries into inner speech, forcing it into the open, is but a rape fantasy directed at language-as-word. Closer to frightful reality, though, are the emergent political-behavioral sciences which, through polygraph, blood pressure, and other physical measurements, seek to detect the deeper response, an “inner” response, from those willing to submit to the poll.

In spite of the genuine insidiousness of such a “science,” which lies in its ability to persuade persons to submit for the sake of “science” to such a control, so long as there remains polyphony there remains the possibility of a *refusal*. The call of the other is a “command” but a command that may be rejected by the possibilities of silence.

The refusal may itself be neither obvious nor dramatic. It may lurk in the trivial response, in speech that is empty and inane. The implicit recognition of this provides a stimulus for a more coercive demand on the part of the questioner. Thus the refusal may make its appearance more dramatically as the stony silence that elicits a horizontal possibility.

What is more “closed” than the silent refusal? The prisoner brought before the dictator’s police sits in silence, his voice does not reveal the secrets that he holds within himself. Yet the silence also “speaks” as the horizontal pregnant signification of the face: it affirms the silence of the interior, one aspect of the hidden which is essential to all speech. Silence lies “close” to speech in such a refusal. The dictator’s police turn to torture to extract what is hidden, but the forced response, the forced confession remains inauthentic even if sometimes it attains the dictator’s objective. The refusal lies at the horizons of speech; it is where language-as-word retreats to the interior but also where silence itself reveals the significance of the horizon.

If there is an ethics of listening, then respect for silence must play a part in that ethics. But ethics is even more fragile than the ideal moments when a conversation becomes the exchange of single voices and open listening, because ethics must depend on a silent agreement of humankind that itself already presupposes a certain unanimity of voice and thought. Ethics must take its place second to a sense of community. Nevertheless, it remains that respect for silence is essential in spite of the fragility of such an ethic.

Yet in the very midst of the fragility of ideal listening and speaking, in spite of the double fragility of an ethics of listening, and despite the continued and predictable continuation of the reductionist strategies that seek to control language-as-word, there remains what is easily forgotten. The “darkness” hidden in voiced language is in fact not a weakness of word but its strength. It is the ultimate withdrawing Openness of the silent horizon as full ontological possibility. The relation of voice to inner speech and to the pregnant silence of the face gives way ultimately to the Open horizon of silence. Here is constituted in effect an *ontology of listening and voice* in the sense that there is a permanent set of existential possibilities that exceed the strategies seeking to control or deny them.

The richness of language-as-word thus lies not only in the focal clarity that can be developed despite its own “darker” side, which forgets the Openness that situates whatever clarity is attained, but also in the untold and

unsaid possibilities of that silence. In this, language-as-word is a kind of music. When a composer or creator of music begins to combine the sounds that will be the musical “statement,” he may, as it were, “out of nothing” add sound to sound. The Openness of silence allows this even to the extent of the creation of a cacophonous music. The “final” limit is not reached except in silence. A noisy music that became so cacophonous and intense, to which “nothing more” could be added, appears itself as a kind of silence

The more restrained music, which in turn allows pregnant silence to situate the sound, nevertheless retains its own relation to the horizon. And in the relation there remains the structure of presence to the surrounding, withdrawing, but Open horizon that always allows a further possibility.

It is in this respect that the poet, like the musician, will always have *a further word*. The creation of a new opening remains a relation to the Open. In this there is no necessity to create a new word as such any more than there is a necessity for the musician-composer to create a new set of instruments, although both such possibilities may be grasped. It is rather a matter of discovering a different gathering of words that allows a new possibility, a new relation to the Open, to emerge.

A further word, compared to the desire for completion and closedness, always remains “beyond” the central clarifies which conceal their own relations to silence, but a further word also remains penultimate, because *there is no last word*. The last word, rather, is no word as such. It is the withdrawing Openness which is the “other side” of word but which is bound to every word. The deepest and most profound listening hears not only the voices of the World, it is a waiting that is also open to the possibilities of silence.

Within the “music” of language-as-word, the penultimate word of the poet that is matched by the penultimate musical “statement” of the composer remain but other cases of extreme examples, of amplifications of the existential possibilities of daily life. Every conversation, every meeting of the other hides within itself the possibility of a beginning. This beginning may be as prosaic as the generation of new sentences that the linguist today recognizes as a problem in the understanding of speech. Or it may be more intimate as in the beginning of a conversation that opens a friendship for a longer conversation. But as the beginning it is a beginning in the midst. Beginnings occur within the whole range of language. When they occur in the midst of language-as-word there remains the hidden pointer to the forms of silence, the pregnant silence bespoken by the face, the “outer” silence that masks inner speech, and the ultimate horizon of silence as the Open. In this sense the beginning of man is in the midst of word, but word lies in the midst of silence.

This page intentionally left blank.

Part V

Phenomenologies

This page intentionally left blank.

Chapter 17

A Phenomenology of Voice

In the beginning was voice and the voice was speech and speech was Language. That is the case with the realm we call human, not that we are entirely different from the animals of the kingdom who are as perceptually immersed in the world as we. We can recognize the cat as she focuses her attention on the morning squirrel, selecting this particular creature out of the vast complexity of the background of other beings and events. The cat evidently has those gestalts and figure/ground relationships that structure its world as ours.

Yet even in our perceptions, we find a lurking persistence of meaning that simultaneously involves and distances us from our immediate environment. For us to observe the cat watch the squirrel is to have placed both in a familiarly placed context, with names that give us Adamic power over them. Our language, however, is itself perceptually situated, embodied in receptive and expressive senses and bound to this primordial attachment to the world.

So, with language there is nothing without its concrete perceptual dimension. It is first heard, then spoken. The infant, even in the womb, hears the voices of language. Just as we—if we attend to it—feel our voices when we speak, resonate and cadence within our torso, so the infant feels the voice of language before it is thrust into the lighted world. Expressions of anger, of soothing song, and the familiarizing drone of daily speech is part of the memory of that time before distance. The voices of language are heard before spoken.

Language that in speech that in voice is that sounded center that our imaginations reach beyond the familiar. It is possible for us to imagine the first expression: a call, a scream, a yelp of delight, a nascent song, but even the first word is imagined from the unspoken and taken-for-granted center of already meaningful Language. We can no more pretend to imagine the fullness of a bare perceptual world prior to speech than we can imagine the nonexistent dimension of light and dark that structures the blind person's experiences. (The "darkness" of the blind is as metaphorical as is his use of "I see you" while touching my face. It is a language without reference. It would be as easy for us to fulfill an imagination of the infrared spectrum seen by the bee as to imagine the total absence of light/dark in blindness.)

But a perception steeped in Language poses a problem for us that we may not even recognize. For it is a perception that is always too quick to make familiar the most strange and other that we come upon in the world. Perhaps only for moments do we come face to face with that which is truly other, and then we give it a name, domesticating it into our constant interpretation that centers us in the world.

I experienced such a novel event when I first heard the recorded sounds of the humpback whale. For the first moment the marvelous range and pattern of the whale voice presented the unique, never-before-heard. But too soon I began to bring this "song" into the familiarity, first of metaphor, then of name. I analogized the whale's voice such that its low notes were "like" those of a bellowing bull, its high notes "like" the shrill of a bird, and so on. This had also already been done in that the dust cover of the record proclaimed it as "whalesongs." In so doing the strangeness becomes domesticated.

Naming, however, is not neutral and our metaphors serve both to identify and guide, but also to take in certain rather than other directions. The biologist who named the utterance of the whale "singing," clearly had the metaphor of birdsong in mind. But is even the song of a bird a song? If what we claim we know of the bird is correct, that its voices are those of territorial proclamation, of courting, of warning and calling, then the song is both like the opera with its melodrama and unlike the opera. For the melodrama of opera is acted, and song, even improvised, is a species of acting—but the bird is immersed in an acting that is simultaneously its very life. Even its vocal posturing has real effect.

What does the whale do? Does he sing like a bird, or like the old operatic whale, sing of Figaro? Or does he speak the voices of language and communicate with his kind? Or all of these? There remains an essential mystery to the voice of the whale, a mystery that we have not yet fully

entered, but that we might forget if we simply allow the whale's voice to be domesticated as singing.

Our language/perception, a single phenomenon, is simultaneously that which involves us and distances us from the voices of the world. On the one hand, it allows us to bring close the voices of the world, into a familiarity that identifies and structures our expectations. We "know" what to expect—just as the Rousseauan-inclined anthropologist can be inclined to find the noble savage, or the Augustinian, inclined anthropologist the instance of original sin—we, too, at the instant of identifying, know what to expect. Perhaps only rarely do we find ourselves shaken in our predispositions, such that the other breaks through in the voices of the world.

This strangeness can, however, break through even that which is presumably familiar. Religious chanting takes many forms and most persons recognize its forms immediately. But in the case of certain Tibetan chants a new and different phenomenon occurs. In its rhythmic and even repetitive movements the chant moves from monophonic to harmonic expressions, and lacking the presence of the monks, we are perhaps led to assume with our usual predisposition that the harmonic expressions are those of the choir—whereas in fact the polyphony is the voice of a single monk and the monophony that of the choir.

The Tibetan chant inverts what we ordinarily expect. It is an auditory figure/ground reversal, but a reversal that is quite typical of certain Eastern values. The same phenomenon occurs in certain kinds of Japanese paintings. What stands out as a single branch, often somewhat abstractly or expressionistically sketched, we might well take as the figure against the vague and indistinct ground of the background. But the seeing that is called for is to see the figure only as that which sets off the true subject of the painting, the Open, or the ground itself. The background is what is focal in this inversion.

Here we reach, however, a phenomenon well-known to phenomenologists, the phenomenon of multistable possibilities, simultaneously open yet structured. In the early days of radio, Georg von Bekesy discovered such a multistability in the ways in which the first listeners heard music through earphones. Some heard the music as if it were in front of them; others heard the music in a 180-degree reversal, as if it were coming from in back of them; and still others heard it "in the middle of their heads." Here were three different possible stabilities.

These possibilities are related to the double spatial presence of sound that we ordinarily experience when listening to music. To hear music is to simultaneously experience it both as directional and as atmospheric. It

comes from a “there”—perhaps from the orchestra in front of us if at a live performance, *and* it surrounds us as a musical atmosphere in which we feel immersed. In the instrumental transformation of these two dimensions, the multistability of different possible directions occurs.

The same multistability may be illustrated visually in this simple line drawing:

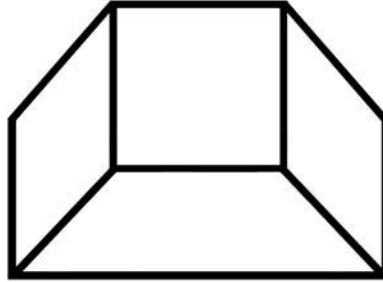

FIGURE 17.1 Multistable Image

This visual phenomenon is one of the well-known reversible drawings. For example, it may be seen as a “hallway” in which the central configuration is seen as a “rearward” appearing (and the viewer downward as it were from its position). Or, it may be seen as a topless pyramid with the central configuration upward or forward facing (and the viewer now elevated into a more birdseye apparent position). But this bistability does not exhaust the figure, since it can also be seen two-dimensionally. This time it is a “headless robot” that is standing directly upright, coming toward you, with the central configuration its body, the lines to the sides its arms and legs, and the uprights crutches on which it holds its headless body.

Now in both the auditory and the visual version of multistability, we may note that each possibility is one that can actually be experienced in a certain way, but while so experienced the other possibilities equally there to be discovered are not experienced. There is an alternation of profiles or possibilities, but all belong to the structure of possibility exemplified by these phenomena.

What I have been suggesting is that our language/perception overall functions in this way. In language each name, each metaphor allows us, if it is appropriate, to situate that which we experience in a certain way. But it is possible for this guidance, which is in some way essential to perceiving itself to be sedimented, fixed. It is possible that without the new metaphor, the “headless robot” might have been missed. It is possible that one might

see only a hallway perpetually, because in each case there is a genuineness to that experience. But, once having begun the exercise of reversals and having opened the question of possibility, one begins to suspect that there are depths not yet plumbed.

Artists and phenomenologists share a certain practice, the practice of exploring the possible and of doing it in variant ways. Phenomenologists name this practice: it is the exploration of variations in order to discover invariants or structures. It is the purposeful reversal of figure/ground. It is the extension from figure to field to horizon, and so forth. But artists practice the same arcane path, for they show us reversals and deconstruct our metaphors, and in so doing, construct new ones with new perspectives. In music John Cage has frequently done this. By performing silence, he inverts the usual, the expected, and the multistability which occurs may be focused either on the silence itself, or on the incidental sounds which occur and now become the “music.”

Each new variation, each new metaphor, holds exploratory significance—but with a qualification, it must be seen to be only a variation, for the phenomenon itself doubtless hides more yet to be found. It is with this forewarning that I turn more precisely to the task here: a phenomenology of voice.

Voice is, for us humans, a very central phenomenon. It bears our language without which we would perceive differently. Yet outward from this center, voice may also be a perspective, a metaphor, by which we understand part of the world itself. For metaphor is to language what perspective is to perception, and both are integral to the way in which we experience things.

Languages in miniature—metaphors—are ways of seeing, of hearing. Aesthetics teaches us that perhaps better than most disciplines. It now seems strange to us that prior to the nineteenth century in the West, mountains were not often seen as beautiful, but rather as threatening, as blocking, as foreboding, until the landscapists domesticated them and made them objects of beauty. Or, take the now seemingly silly practice of the nineteenth century in which framing landscapes became a passion, with travelers regularly looking at the scenery through an oblong wire frame, thereby creating a framed, picture-like landscape. But perhaps this is little different than our contemporary artists who now go about draping coastlines and islands in plastic, thereby transforming the landscape into a kind of art object.

Similarly in music, the contemporary introduction of noise to be taken as music, of random sounds, of monotonous sounds, all strain at making a new gestalt for listening. This is artistic playfulness that the phenomenologist can also appreciate. And my first move beyond this setting of context is to do similar variations with the idea of voice.

What if we take voice—which in a narrow sense is distinctively human—and first expand it as a metaphorical perspective, following a suggestion of Merleau-Ponty who spoke of the “voices of silence,” and of “singing the world.” The metaphor is serious and not frivolous, for there is a deep sense in which all things, the things of the world, have voices. We miss this because of at least two things: first, we exist in a language world that is frequently dominated by visualism. Thus often perception itself is reduced to the visual. This does not mean that I wish to substitute a different sense as model here, because I do not more wish to simply reduce the visual than to simply enhance the auditory. What I am trying to do is to demonstrate the sedimentation which is reductive, reductive of both the visual and the auditory.

The first set of voices I wish to point out are those of material things. For every material thing has a voice—which, however, is all too easy to miss. First, we may miss the voices of things because they are often, left by themselves, mute or *silent*. We recognize this when the silence is dramatic and overpowering. The city dweller who for the first time finds himself or herself in a desert might think the desert silent by contrast—but this silence is only relative in that a careful listening would hear the heat crackle of the sand, the small sounds of insect life, and perhaps the slight voice of the wind.

But individual things might well remain silent, their voices not active. Yet each thing can be given a voice. The rock struck, sounds in a voice; the footstep in the sand speaks muffled sound. Here, however, we must note that the voices of things that are often silent are made to sound only in duets or more complex polyphonies. When I strike a lectern you hear both the voice of the lectern and of my knuckle. When I use a pen to strike the water pitcher, you hear both the sound of the glass and of the plastic, simultaneously in a duet of voices of things.

Here we must attend carefully to our perception. For to isolate the voice of a thing, we must listen carefully and focus on one of the voices in the duet. We can do this in making one of the voices focal—the auditory figure as it were—and the other background. If we listen to a quartet of instruments, we can select out the clarinet to attend to even while the oboe continues to play simultaneously. And to listen to one voice of a duet is what we must do if we are to hear distinctly what is said in the voices of things.

And what do we hear? The answer is much, for the voices of things bespeak the multiple dimensions of the thing. For example, the thing bespeaks something of its material nature in its sounding. The solidity of the table is bespoken when it sounds, even in some cases telling us of its kind of materiality. The wooden table sounds differently than the metal table.

The brass goblet bespeaks differently than the glass goblet. Each bespeaks something of its nature. Moreover, it cannot do otherwise.

More, it also bespeaks something of its shape and dimension. The voices of things often tell of interiors. By tapping on a wall, I can hear whether it is solid or has a hollow behind it. By striking the barrel, I can tell whether it contains only air, or is filled with some liquid—or even if it is but partially filled. Interiors sound. They are bespoken in the voices of things.

Or, I may take the voices of things and let them reverberate so that I can tell something even about that which remains silent. For example, if I strike something in a large auditorium, the space that is auditorily given to me is distinctly different than the space given by striking the same object in a closet. And again it is different if I am in a room with bare walls and hard floors, than in a room filled with drapes and rugs. In short, our listening experiences a complex and multidimensioned richness of things that sound, but which we rarely attend to with deeper attention than ordinary consciousness.

The same occurs in the voices of nature, where at least a duet is heard in the wind and trees, but more often a multiplicity of voices sound at once, thereby making the isolation of singlenesses difficult and thereby precluding the tendency to discrete isolations. This community of sound, this multiplicity of voices is also frequent in the natural world. The multiple voices of waves, wind, and sand constantly sound the multiplicity of voices of the things of nature.

All this is to say that the sound of voices taken in this sense is constant and complex. So long as we are conscious there is a sounding world (similarly, visually, even when we close our eyes, we see—the darkness of our closed eyes, or the faint glow of bright lights through our lids). If the voices are taken as a kind of music, it varies in place to place and time to time from pianissimo to forte, from a few voices to many, but it is never totally silent. And the most silent of the things of the world, can be given sounding voices in the duets of contact and motion.

Taken in this way, we invert the usual relation of music to the field of sound, for there is a fundamental sense in which the sounds of the world are the first music, with what we call music in a narrower sense as a kind of abstracting from this auditory realm, perhaps setting it in an auditory frame, perhaps enhancing and embroidering upon it. So, in a kind of ironic turn, by taking the world as voice and music, we come to see what we ordinarily take as voice and music is a particular configuration within the world of sound.

And there is more that we can discover in this phenomenological playing at the edge of artistic practice. The contemporary penchant to change

perspectives may also be seen to fit here. Insofar as anything can be given a voice, it can become an instrument. Thus the musician who takes the world this way, may play the things of the world as instruments, improvising among the voices of things. The street urchin who runs a stick along the picket fence, or who drums a rhythm out of garbage cans, is giving voices and even a kind of music to the things of the world. "High" or "fine" art is in this sense but a refinement of possibilities discovered in the voices of things. The things of the world are thus instruments as well and anything can be an instrument, made to sound, to give voice.

The voices of things are not the voices of language. For what the voices of things bespeak is a kind of direct sound of their natures: materiality, density, interiority, relations within experienced space, outward hollows and shapes; complex, multidimensioned, often unheard in potential richness, but spoken in the voices of things.

When we reach the kingdom of animal voices, however, we reach the neighborhood of language. For here expression begins to occur, expression of more than material nature, expression of action and emotion. First note that the voices which begin to be expressive are communitarian in voice. Many creatures in the animal world behave more like choirs than individuals in conversation. The coyote who begins to bay at the moon is not long in solo, but soon is joined in choir. Geese in flight honk in a virtual cacophony. The baboon troupe does not fret itself about who interrupts whom, for all chatter while on trek. And there is expression in these voices. Who can mistake the contentedness of the purr of the domestic cat, the excitement and genuine joy of the dog whose master returns? The range from whimper to the distinctive sounds animal owners recognize for food, for strangers, for warnings, for other animals show the expressivity of the voices of the animals. Take, too, the mimics. There is unintended visual mimicry: the viceroy butterfly mimics its larger, presumably ill-tasting monarch in pattern, color, and design. But the mocking bird, parrot, and cockatoo all consciously imitate and mimic the voices of others. Here is an expression doubled on itself, the wedge in sound that opens the way to what becomes in the voices of language the complexity of the ironic, the sarcastic, the humorous, and all the multidimensionality of human speech, particularly in its dramaturgical form.

Although I shall not explore all the possibilities of animal communication, I think it should be obvious that in speaking of voice here, if not yet of the voices of language, we are leaving the sense of metaphor and entering the neighborhood of voice at its center. Although—if there is an animal vocabulary—it may be narrower, and if "language," less rich and transparent, the possibilities of expression are already beginning to open.

For with animals as with humans, voice is an active expressing of relations with others and the environment. Voice changes the way we so relate and frees us from the limited territory of the unuttered. There is a kind of auditory migration that begins with voice, even in the kingdom of animals.

Animal voices usually remain close to that which we discovered in the voices of things. This is especially the case with spatial significations. Calls tell where the speaker is as both part of the communication and as directly heard. And there is a vestigial sense in which the voice of the animal bespeaks its nature. The bird-watcher, without looking, awakes to the calls that are those *of* the bluejay, the white throated sparrow, the grackle. But in another sense the material nature of the animal is now often belied. For the smaller creature may speak with a louder voice than the larger. And with the arrival at both mimicry and the active posturing that expressivity allows, the voices of animals begin to open to the dramaturgical. The gorilla's visual (chest pounding) and auditory (roaring) gestures are simultaneously posturing and actions, creating the aura that is distinctively gorillan.

Animal voices, too, serve as musical material. One movement in the West was obviously outward from voice to instrument, with early instruments as quasimimics of voice. But animal voices are also that from which a music can begin. The sounds of primitive flutes, particularly in Andean music, are birdlike and birdsong often is the theme around which the music takes shape.

I have been moving from outward back toward the center, the voices of language, which are the position from which we experience the world. I have suggested that precisely because this is where we live and breathe and transform breath into more than breath, into voiced speech, that we have difficulty understanding this center. So given as this center is, so familiar and taken-for-granted, and for precisely that reason so opaque, it is not without reason that we humans have turned to often fruitless speculations about the origins of language.

In philosophy the question of language has been the preoccupation of the twentieth century. This is the case both in the dominant Anglo-American analytic traditions and with the Continental traditions. And each tell a different story. On the one side the tale is told of an origin in descriptive naming: the first word of language is predicating a "literal" description to some existent object. S is some kind of P. The other tribe tells a different tale: the first word is a kind of metaphor that may be a primitive kind of expression, but one with multiple significations. And between these tribes arises a warfare in which the one claims that the multiple (the metaphor) is a built-up complexity out of simples; while the other claims that the simples are "dead metaphors" reduced from rich original expression of an original word.

But these tales of origin, like the myths that every human group has about beginnings, are, while imaginative and suggestive, ultimately fruitless. For we cannot find, return to, or isolate a first word. Even the mythology of the child is useless because members of one of these tribes will hear in the child's first word a name, which may be taken to mean one and only one thing; while the member of the other tribe will claim that the first word is something like all of language in a word, used in many ways until it diversifies as it does in learning. (But I would remind us of the earlier observation, that for the child, language is first heard, long before expressed, and thus whatever the first word is, it merely responds to the totality and complexity of the voices of language already familiar, acted upon and even in some sense understood.)

These origin speculations are not unlike speculations we might make about the first music. Was music made fist by playing one note? A stick hit against a hollow tree? Or was it invented by the tribal singing that early humans, like their animal cousins, indulged in *en masse*? Obviously, we can never know which, if either, of these is the correct tale and we waste our best thought by pursuing such tales unless we realize they are but tales. For what we have are the already full voices of language and we find our center there.

And what of these voices? Are they one? Or many? Simple? Or complex? By avoiding the tales of origins, we are closer to a possible answer. For, whatever else the voices of language may be, at the center where we are, they are rich, multidimensioned and filled with as yet unexplored possibilities. But we should have expected that already from what we have noted about even the voices of things. The problem with the voices of things, below the level of expression and communication, is that too much is presented.

In bespeaking the possibilities of nature, of shapes, surfaces, interiors, surrounding spaces, there is too much "truth" as Merleau-Ponty observed. We have to interrogate with specific questions, specific actions, if we are to learn the possible lessons of the world. We do this, of course, without necessarily being fully aware of it. For example, we actually rather constantly "echolocate" as we now call auditory spatial orientation. Sometimes I conduct an experience experiment with my students to show this. I take them into an unobstructed and hard-walled corridor and draw a chalk mark down the hall and tell them to walk to it; turn around; and return to the original starting point. In doing this I ask them to attend carefully to the sounds of their shoes as they echo against the walls, opening the way to the variants they are about to undergo.

Then I have them put on a good set of ear muffers (mine is a set that I use in chain sawing, like those that airline workers use near jet planes). These muffers, while not closing off the world of sound, do muffle it suf-

ficiently to dramatically demonstrate what we would experience without echolocation. It is at first a rather unreal experience in which the solidity of the floor even seems muted. And one obviously has to sharpen his or her visual attentiveness to the task at hand. Then, I have them put on a blindfold instead of the ear muffler and perform the same task, now more aware of the role of echolocation. And, interestingly, few fail to do a right approach and most report that they can now hear the distance from the two walls since they are now attending to what they had all along done without noticing, but now notice more fully. This, in short, is a sharpened question put to the world. In the last variation, the student tries with both blindfold and muffler and in this case, almost invariably, the wall is soon encountered. Our spatial orientation is not and never has been simply visual—yet we have often so interpreted it.

Now the reason I returned to this voiced spatiality of things here is to suggest that we may be as badly off in our usual interpretation of the voices of language as we have been in our interpretation of experienced spatiality. And, if we are to begin to probe the multidimensionality of voice, we will have to pay subtle attention to it at its most dramatic point.

That is why I shall turn to what I call *dramaturgical* voice.

Human voice recapitulates what we have previously noted. Even from the world of things, voice retains vestigially some sense of the materiality we are. Sometimes, and against the will of the speaker, what is spoken is not desired. The wheezing voice of the emphysemiac, of the too-far-along smoker, bespeaks the interior state of the body and its pathology. More mundanely, the spatial significations of where, of direction, and of surroundings are also sounded. The playful hollering to catch echoes in the mountains is a variant of the sounding of surrounding space we found a possibility of things.

But as the realm of animals in the neighborhood of language reveals, expressivity is not only of material nature, but of expressivity. Not only the where of speech, as in a call, is presented, but the *who* of voice. The distinctiveness of voice, even transformed over the telephone, is recognizable. And in this recognition we have a phenomenon that is probably known also in the animal realm. The “who speaks” is never auditorily only a where, nor of simple distinctive pattern. It is also musical in that musical sound enhances the directionality and the atmospheric dimensions of sound. So with voice: one’s voice is simultaneously there, and it is a kind of surrounding. It presents us with an auditory atmosphere, an auditory aura. The self-aware dramaturgical speaker knows this and enhances this phenomenon. The actor’s ability to project, the orator to enhance resonances, thereby enhances the aura of dramatic presence.

With expressivity, the doubling of significance is also possible. Mimicry, perhaps the simplest doubling, is elaborated in the human realm by all manner of doubling. Irony, sarcasm, duplicity, and even lying become possibilities, as well as humor, double entendre and wit. All of this is expressed vocally, auditorily.

All speech is dramaturgical in a significant sense. This is not to say that there is not good or bad, appropriate and inappropriate dramaturgy. Among my tribe—the philosophers—there is a notorious and sometimes even highly valued amount of “bad” dramaturgy. A technical, detailed and better-read-than-said paper, read dryly and monotonously at a professional meeting is not undramaturgical. It often “says” far more than it intends and the dominance of this kind of speech probably is one factor in the decline of undergraduate interest in philosophy in recent times. But it is its own kind of dramaturgy—a kind of dramaturgy that tries to deny itself. The “truth” is not to be found, so says the tribe, in the way it is expressed. But this is to mistake the possibility that the “truth” might just as easily be discovered in the felicitous and well-voiced expression as in the dullest.

The multidimensioned possibilities of dramaturgical voice, however, also exceed the dimension of mere expression. Dramaturgical voice reveals a world. Here we reach the voices of language. For through the voice, a world is presented. And with it a curious thing happens. The very voice which at its height of good dramaturgy, simultaneously draws attention to itself, and yet denies itself on behalf of the world that is presented.

This is what the poet does. Poetry (which in our examples may be assumed to be read aloud) does draw attention to the language, to voiced language. There is a beauty to the words themselves, the cadences and rhythms of the poem. But there is more, for *through* the voice of language in the poem, a world or a new perspective on the world is heard.

What lies within these voices, central to the very way we experience world, is almost too complex to deal with. For much is said in even the single expression. Here, however, what is voiced, sounded, is our focus. For the sound of voice already bespeaks much. The modulations that are sounded, we already know, for even a word is multiple in its auditory context and if I address you as:

You!
You?
You.

I have already voiced three different possibilities of the voices of language. And I have done so in the economy of voice, situated as it is in the

unspoken but understood field of language. This silence, this unspoken background to the foreground of my words is also part of the voice of language.

Every dimension of spoken voice, carefully heard, presents a multiple dimensioned wealth. This is particularly apparent in purposeful dramaturgical voice. Even the "who" of speech is multiple. This phenomenon is probably most familiar in the voice of the actor or the singer. On stage or in cinema, Richard Burton plays a role and in the role there are two voices that synthesize. The Hamlet he plays is vocally animated out of the drama, yet it is Burton's Hamlet. The Pavarotti who sings the Duke in *Il Trovatore* is both Duke and Pavarotti. Here is a recapitulated set of dimensions which range from the unmistakable "nature" of individual voice to the exhibited voice of another.

This same possibility is taken even further in the dramaturgy of liturgical voice, for in the more extreme cases, the voice of the cantor, the priest, the liturgist is disguised and amplified within the echoing space of the cathedral, synagogue or temple, so that the voices of the gods may once again be heard. Again, an extreme example of such a voice one may again recall the Temple chant of the Tibetans. Those who sing-chant the polyphonous voice of the sacred, are selected at childhood for lifelong training, so that the dramaturgy of their voices can be the voices of the gods.

What dramaturgical voice presents is the multidimensioned and multipossibilitied phenomenon of voice. The voices of language, display for us a range of possible worlds, themselves multidimensional. And the voices of the speakers also double and redouble throughout the range of possibilities. This is the primary phenomenon. But it is not all. For although all language is embodied, and it is first embodied in sound, heard and then spoken, it also has become differentiated in such a way that voice no longer stands alone as that perceptual-linguistic way of experiencing the world.

I refer to writing as a visual embodiment of language. For sometime in a past no longer remembered, sound became at first related to letter, and then submerged in writing in the modern sense in seen, but unsounded words. This momentous gestalt shift, now taken for granted, was probably itself gradual.

Briefly take note of a few overlappings in this emergence of a different embodiment of language. Early reading was apparently habitually reading out loud. The student who discovered Ambrose reading silently, without even moving lips, was witness to a profound change and separation within the realm of language in a visual embodiment. This later development has become so much the case that today we are often surprised when we pick up a book, written by a friend, and hear in our reading his or her voice.

Today, again within the tribes of philosophers, the phenomenon of writing has become a preoccupation. This is particularly the case with the contemporary and primarily French poststructuralist traditions. Derrida proclaims, extremely, that writing that precedes speech in the form of inscription and “trace.” Lyotard speaks of a writing that writes itself. And in the focus on writing, the deconstruction of the self occurs—for writing can hide a self far better than voice always carries within itself that recapitulation of voiced self.

Moreover, the emergence and evolution of writing has today led to an even more extreme set of possibilities, unvoicable writing or “language.” Here I refer to symbolic or constructed languages, those of symbolic logic, of mathematics and of computer symbols. Language no longer voiced. Given this possibility, voice may be forgotten, covered over. This effect, I would contend, may be detected in a number of disciplines that relate both directly and indirectly to the auditory realm.

A few examples: Phonetics, which is presumably the discipline that deals with sounded words, in effect reduces spoken language to a kind of code of letters—translates sounds into the units we may call broadly, letters. The phonetic alphabet, a shorthand for discrete sounds, is a set of letters for sounds. Thus phonetics, not unlike the latent visualism in most of our science, learns what it learns by first translating an auditory realm into a visual one.

The same happens with attempts to learn speech patterns by playing them on an oscillograph. Again, what is sounded is translated to a visual pattern. Distinctive voice “signatures” perfectly well recognized in a listening gestalt, now may be made to “stand” on the photographed pattern and taken account of visually. We can then repeat and make stand still the utterance. These are all attempts, often successful, to reduce and translate auditory to visual forms.

Here, however, we place ourselves at a crucial juncture, one that could take us in the wrong direction. For we are faced with the possibility of a Romantic nostalgia. We see this accelerated translation of auditory to visual and in it, surely, there lurks the possibility of a “reduction” of the auditory and of a forgetfulness of its richness. I do not deny that this is possible. But if, then, we decry the now doubled presence of perception/language in this auditory/visual, we place ourselves in a similar role that is to merely reassert another privilege.

Too much is gained, genuinely, in the new variation. And the sciences of phonetics, linguistics, and the advances of literacy are too vast to simply dismiss or reject. If, in the new visual, that is not the greatest danger. The greatest danger is the second reduction that reduces both sound and

sight to such notions as “information”—as if the only thing conveyed in speech and writing is what the technology proclaims.

The forgetfulness that is possible is always at most a partial and particular forgetfulness. At its worst, it can cause us to overlook and to become insensitive to the full richness and range of the auditory. And it can take us in certain, rather than other directions. In music, for example, the introduction of writing is the introduction of notation. Notation does for music what writing does for language. For example, it allows repetition. While every performance is different, every interpretation different, a core signification remains discernible and Beethoven’s Fifth remains his Fifth just as Burton’s Hamlet remains Shakespeare’s Hamlet.

Such a tradition, now deeply engrained in our practices, is essentially different from music in oral traditions (which are in a sense now hard to find). In recent times, through tape-recording folk music, particularly, in isolated rural areas of the world, we have discovered that even the notion of the “same” is different in oral compared to literate cultures. The “same” song, particularly if it is one with many verses and complex, will on the tape both be different through time with a single singer, and different with different performers—yet both will proclaim that they have sung the same song. Here the core persistent significance of the song is not that *literal* repetition of words and notes that it might be for the literate culture, but the pattern, the overall sense of the song. “Sound” is not the letter, but is the spirit of the song.

This is not to say that either precision or excellence of performance is enhanced only in a tradition that follows notation. Rather, it is that a tradition of notation can enhance discreteness, strict repetition, reproduction. The same thing happens when we “read” time, as in clock cultures. All peoples have a sense of time, and we know that nonclock cultures (again hard to find) may be said metaphorically to have “read” time from the sun and moon and stars. But this is not true—such was not a reading and its results are different. To speak of “reading” in this sense is to anachronistically project our sensibility into another time and space.

But once having begun to read time with instruments the trajectory toward the discrete could begin. Clocks—even earlier the sundial and waterclock—represented time as an instant portrayed by the pointer moved. As clocks evolved, first from those that had only hour hands—to mark the hours of devotions—to those that then introduced minutes, then seconds, and now microseconds, the tendency toward enhancing the instant and to enhancing the discrete accelerated. So that today, with a digital clock, we no longer even represent the field of time in which the instant occurs. In this we not only change a perception of time, we also reduce its dimensions in our representations. What we gain in discreteness, we lose in expanse.

My point here is this: different embodiments entail different selectivities. The same applies to speech and writing. And within the same realm, the same applies even to differences such as those that scored compared to improvised musical performances display. The variations display differences. In speech there is an economy that is possible in expression. The here-and-now perceived context, while unspoken is apparent in the communication situation. And the multidimensionality of the expression can, in even short phrases, say much. Thus the scream of “Fire,” in a crowded theatre carries with it the experienced context, the sense of urgency heard in the sounding of the voice, and the alarm and imperative of the word. To deal with the same in the representativeness of writing—it would not mean the same nor even make the same sense were the word, “fire,” simply written on a page—one must write out the context which, if skilled might still be economical, but clearly not in the same sense as the voiced situation.

Contrarily, writing can preserve and enrich the sense of that which is *not* here and now. I would never have learned of my father’s crude poetic abilities had I not discovered a package of old love letters between him and my mother while cleaning out the homestead for sale this fall. There is a different gain and a different loss in each of the embodiments of language. And these gains can then be translated positively, as well as negatively. For where the alphabet of phonetics clearly *loses* the individual and dramaturgical sound of a voice in its translation, in the new version of “auditory writing”—I refer to the tape recording—we capture, like writing, what was past and that which can be repeated just as a book is reread.

Central to what I have been saying is the notion of a perceptual multistability. What is deeper, and what is richer, is discovered through the process of variations. To understand more adequately the ambiguous drawing, the reversibilities of figure/ground in aesthetics, is to begin to probe the very structures of possibility. That has always been the phenomenological task, and in practice it is also the artistic task.

The same applies to what may have appeared just now as a kind of detour. For voice, in the human dimension inextricably linked to perception/language, encounters in its history a new perception/language in writing. Each are what I have called embodiments of Language, but each carries its own kind of distinctive stability. And each kind of stability has its temptation to reduction, but also the possibility of enrichment.

When we return from this detour, however, we also reach a juncture with respect to that other human expressivity in sound: music. Clearly, notation is for music what writing is for the linguistic. Yet with a difference—for while writing may gradually separate itself from voice and sound, for notation to become an end in itself without music, is to transform some-

thing beyond its horizon. Thus with notation we reach a curious dialectic. Could music be reduced to the unsounded? translated entirely into the visual? (If so, we should at least be hesitant to call it music except as metaphorical. Indeed, it might be more a dance.) Insofar as music must remain sounded, it is not its score. Yet with notation, music may be performed in ways which exceed the bounds of purely oral tradition. This, of course, is merely to have rediscovered the very history of our music. It is a music, which through the score, is repeatable, controllable, and now embodied in recording technologies, distributable as an auditory library for anyone.

Yet, music also exceeds its notation. And today this seems apparent in the very way in which notation itself must change to accommodate what is sounded. New sounds, no longer bound to the scales and conventions of the past, call for new notations—the symbolic logics of contemporary music. But this is the interplay between the dimensions of the languages of sight and voice that could be mutually enriching.

What I am suggesting comes directly from what I would term a “phenomenological insight.” The discipline that takes the structure and field of possibility as its theme, is the discipline that finally arrives at the notion of a multidimensioned, multistable field as the central model of the world. And what I am implying has at least heuristic value. Negatively, this implies that romanticism can be as reductive as other possible moves.

We noted in the multistable visual figure at least three possibilities: the “hallway,” the “pyramid” and the “headless robot.” Each was an equivalent possibility and one replaces the other in the procession of profiles. But by doing the variations—not even yet exhaustive—we also did something else. We ascended to a beginning insight into the very structure of multistability, an insight that then can guide our subsequent awareness, such that we might well expect both more possibilities and, in other similar drawings, the same multiplicity of profiles.

I am intimating that the same thing happens in the action of language/perception and that the voices of language are a stability that have become supplemented by the writings of language. Reduced to a mere speaking-hearing being (naturally an impossibility even to concretely imagine), or similarly reduced to a mere seeing-seen being, we would clearly experience the world in a flat and reduced way. We are multisensory and have always been so. Interestingly, we have not always explicitly been so as language/perceiving beings. Thus what I am suggesting is that the discovery and invention of writing in all its variations, is like the coming into sight of a blind man. The languages of vision, now exceeding the alphabet, enrich this connection with the world. They are variants on the possibilities of multistability.

All the sound, we noted, is the field which might be called the field of possibilities for music, even as anything might be an instrument, and all voices primordial musical statements., Similarly, improvisation in at least one fundamental sense is primitive. Living is fundamentally improvisation. Without this, any new situation, could be destructive, because the world is constantly facing us with such situations. Yet, we also know that within the world not all strategies are successful. Thus at the animal as well as the human level, improvisation is always related to patterned actions.

Societies, cultures, which are oral ones, can be as restrictedly sedimented and patterned in repeated ways, as even the patterns of animal life display. Thus even the improvisation, the individual way in which traditional Armenian folk song begins with a display of the vocalists range, becomes part of the set pattern of the music.

The voices of language show us the same interplay. For whereas we may improvise an infinity of new sentences in an infinity of new situations, there would be no language without the stability of words, conventions, samenesses which while changing with time, do so in such a way that the letting-be-seen and letting-be-heard is Language in operation.

There is no return to a pure oral culture—or to pure spontaneity—but what I am suggesting is that this is not a loss. A person who both hears and sees is better off than one who is blind or deaf; a language/perception embodied in spoken *and* in written articulations is better potentially than a single embodiment of significance. Yet within each of these dimensions and the range of multistability, there are those who will opt for the security of repetition and others who will opt for change. But he or she who discerns the possible, can “dance” (which is yet another language/perception and yet belongs to the gestalt that is human). And, like Nietzsche, if I am to have any gods, I prefer those who dance in all the realms that we inhabit.

Chapter 18

Auditory Imagination

In this essay I propose to investigate phenomenologically a dimension of human experience that may be called *auditory imagination*. My central aim will be to point out certain phenomena that I claim properly belong to auditory experience and which, if so concretely located, are suggestive of solutions to some philosophical problems concerning man's experience of the world. I do not wish to claim that this investigation is either final or exhaustive, even in relation to the total range of auditory imagination. Certainly one result of phenomenological inquiry ought to be the rediscovery of the amazing wealth and complexity of human experience.

Methodologically I shall assume and employ some aspects of techniques known broadly as phenomenological. Thus my study will be descriptive and direct and I shall neither refer to already performed studies in overlapping areas nor to empirical studies on the same phenomena. This is not to say that such studies are to be dismissed nor that they would not enrich this study.

Second, I shall begin with some very general features of the related phenomena of visual and auditory experience and move from these to the more specific range of phenomena within auditory imagination. In this context of a move from general to specific I shall employ the terms "field" and "entity" to distinguish the general from the specific.

Finally, I shall assume the primacy of the "normal," in a broad sense, over the deficient or the abnormal. The examples used here depend on a

fully conscious person complete with all his senses. Again this is not to say that variations by subsequent studies into abnormal or deficient subjects should be abandoned.

Ordinary experience is global. We are so involved in our traffic with the world that we usually do not notice or reflect on the way in which we experience the world. Phenomenology is one attempt to step back from certain types of involvement with the world and direct our attention to specific features of our experience of the world. Herein lies the clue to the *epoché* and the direction of phenomenological description. Thus while our original experience is global or total we can, nevertheless, isolate certain dimensions of that experience and submit them to descriptive scrutiny. Note here that it takes no apparent effort to experience things globally—but that it does take a disciplined effort to reduce global experience to any given dimension of that experience.

Reflective attention to experience, of course, has not been the total property of phenomenology and we find at hand many “latent” phenomenologies, some of which appear in rather ordinary philosophical and psychological distinctions. Beginning, then, with quite simple distinctions we may begin to look for some discoverable features of experience: (1) We shall first reduce experience by directing our attention to *visual* and *auditory* experience and isolate only some features of each dimension. (2) Note that from the beginning a pair of distinctions may be claimed within each dimension of experience. Two modes of experience, *perceptual* and *imaginative*, are possible for both visual and auditory dimensions. Husserl’s “active” and “passive” syntheses are thus implicitly accepted here.

Given these preliminary distinctions we may begin by noting a limited number of general features of visual and auditory experience.

VISUAL AND AUDITORY FIELD PHENOMENA

As field phenomena visual and auditory perception are constants of consciousness. To verify this we must pay strict attention to both dimensions strictly *as fields*, thus disrupting our ordinary attention, which is involved with entities *within* the fields. In our ordinary affairs things are reversed and we are so involved with entities within the fields that, in “Heideggerian” fashion, we “forget” the field as a whole.

Thus if we close our eyes or enter a completely darkened room we might well say, “I can’t see (*anything*).” Or, if the professor, drawing an *X* on the board, asks, “What do you see?” our response will likely be, “I see and *X*.”

All of these responses, quite understandable if one assumes all the implied meanings of the ordinary context, would be wrong in relation to the fullness of field phenomena. Strictly speaking here we should say with eyes closed, "I see dull red," or something of that sort. With the blackened room we might say, "I see black," or "My visual field is completely black." With the *X* one might just as well go on to say, "I see an *X*; on a board; in a room; *within* a visual field." In each case there is a constancy to the field as "bodily present" so long as we are conscious.

The same constancy of the auditory field may be noted. The constancy of the *field* may be overlooked in instances that are auditory parallels with those of vision. The dark room parallel here is *silence*. We might be tempted to say, "I can't hear (any-sound)." Yet, though in this case it might be more unconventional, we might well say, "I hear the quiet." (I doubt that total silence is possible since in such surroundings one can usually hear his own heartbeat or the blood rushing in his ears.)

From silence to deafening noise, from blackness to blinding light the fields of vision and sound are constant. But our examples are also instructive about our experience as well. It is clear that we do not, and could not, attend to the general features of perceptual fields in any regular way. We remain primarily involved *within* the fields, and there selectively. It may even be the case that we do not pay explicit attention to one or another field at a given time. If the visual and auditory fields are constant this is not to say that explicit attention on them is constant.

It is here that we may note a more familiar feature of consciousness, often noted in phenomenological literature. Consciousness is directional, selective; it is *focused* as a "Husserlian ray." But if we relate the focus of consciousness to the constancy of the fields just noted we may speak of the focusing function as displaying a *core-fringe* structure. This is to say that we may attend to some particular entity within the given field in which case it constitutes the *core* of our attention while all else becomes *fringe*. Here, I suspect, we would need to add further observations about that which is implicit and explicit and that which is manifest and that which is latent if we were to go further with a study of the core-fringe structure of consciousness. For our purposes now note only that while attention constantly shifts (from one entity to another or by distraction by some striking intrusion into our project, such as a loud sound or bright light) it usually remains focused.

But this focus itself is *variable*. Visually I may attend to one object (core) while everything else becomes fringe; auditorily I may concentrate on a single sound (core) and all else becomes fringe. But I may also expand the focus to a given set of objects (I scan the entire chessboard; I listen to

the whole symphony) while the fringe is unattended to (I don't attend to my opponent's chair; or to the coughs of the audience). Here we could go on to note that selectivities differ as well. Thus while the "field texture" of the urban experience of sound tends to be quite loud the urbanite may easily hear the clink of a coin in the subway just as easily as the jungle dweller hears the faintest whisper of the adder amid the parrot calls.

In both cases, however, *the directional focus* of the subject, which is a general feature of consciousness, *may obscure the phenomenon of the field itself*. It is only by reflective effort and by an expansion of focus to the field itself that the field emerges as open to investigation. Thus here within experience we find that one general feature may be obscured by another with the consequence that aspects of experience are easy to overlook.

But we return to features of the fields of vision and sound. If both are constant as fields within which a focus of attention may be operative, what distinguishes the fields as fields? The usual phenomenological answer would be to say that any field is distinguished by the characteristics of its "objects" (noemata). I do wish to quarrel with this insight since the visual features of visualizable entities (colors, etc.) are distinguishable from auditory features (pitch, etc.). However, field characteristics differ as well.

Kierkegaard's *Either/Or* suggested that sound, especially music, is temporal while that which is seen is spatial. This contrast, which is suggestive for further phenomenological elaboration, should not hide the fact that the auditory field is not solely temporal any more than the visual field is solely spatial.

THE SPACE OF VISUAL AND AUDITORY FIELDS

Here we restrict our interest to the spatialities of vision and sound as field characteristics.

The spatiality of the visual field is a space *in front of the* subject. Moreover this space has the definite characteristics of being limited to a finite *roundness*. There is a border to my visual field and what is actually observed as always bounded by the "invisibility" of that which lies beyond. Here I may correctly say, "I do not see (beyond the roundness of my visual field)." Of course I may turn my head or eyes and see more of the world, present as anticipated, meant, or intended but not visually present outside my visual field. But even when I turn my head the visual field *as field* remains before me in its finite roundness. The space of the visual field is limited to being in front of me.

The spatiality of the auditory field displays a different character. It is clear that within the auditory field we may speak of the direction of a given

sound (it comes from behind me) and of particular sounds we may perceive as being near or far from us. But as a field, we must say that it *surrounds* us. I am immersed in the auditory field that displays no definite boundaries such as those of vision. The sound field, unlike the visual field which remains in front of me, displays an indefinite space in all directions from me. Note in passing that I may speak of myself at the *center* of auditory space. And note also that the indefiniteness of auditory space proceeds in both directions—it extends indefinitely from me but it also “invades” my being. (A physiologist once remarked that a well-constructed theater would present sound “in the middle of one’s head.”)

IMAGINATIVE EXPERIENCE

At this point, despite the fact that the general features of the visual and auditory fields are far from exhausted, we must begin some variations taken from the imaginative modes of visual and auditory experience. I do not intend here to enter the complex problems of the relationship of these two modes of experience other than to offer a tentative belief. It would seem, with Merleau-Ponty, that perception remains the primary, or at least the primitive mode of experience in which the world is presented to us.

Imagination, if restricted to “imaging,” would seem to be dependent on perception. Thus while one may imagine visually all sorts of imaginable animals the, like their perceptual counterparts, would still be colored and spatial.

However, there are ways in which imaginative activity, taken here as an “active synthesis” *exceeds* perceptual modes of experience. Further, there are variants within imaginative activity that make the activity quite distinct from perception and that raise some questions as to the primacy of perception.

Some General Features of Imaginative Activity: When we speak of imagining something one general characteristic of the human activity immediately emerges. All imaginative activity allows a free variation of its contents. Thus while in the imagination of fantastic animals it maybe possible to void the imaginative field of color characteristics, it is possible to imagine blue centaurs or green griffins such as have never been perceived and thus “make possible” their perceptual appearance in statuary or pictures. Free variation of contents remains one general feature of imaginative activities not possible for the “passive synthesis” of perception except within limits (recall the famed ambiguous pictures of duck-rabbits that may be varied at will).

But first as a variation on the general features of visual and auditory perceptual fields, do imaginative activities display the same general features?

For example, are the visual and auditory imaginative fields constants of consciousness? Here the field phenomena are more difficult to describe even than in the case of the much more familiar perceptual fields. The reasons for the greater difficulty may be varied. We may remind ourselves that just as attention is focused within a perceptual field, so it is within imagination. And this to the extent that a given dimension may be obscured (perceptually I am so intent on the picture that I fail to notice my wife calling me, or imaginatively I am so intent on my transparent Pegasus that I fail to note the black background against which he is etched) by the focus.

I also suspect that imaginative activity in general is more difficult to deal with because it has something to do with the very way in which we are present to ourselves. Nonetheless, there are variations that may help display our thinking-imaginative fields. The old challenge, “Try *not* to think of a white bear,” is an entity version of a possible field question, “Can you ‘turn off’ your thinking altogether?” I suspect that the answer must be a qualified “No.” If so then some form of imaginative activity remains constant in consciousness just as the perceptual fields do. Consciousness may be consciousness of ———, never contentless, directed as phenomenologists claim, but it is also complex in the sense that its modes are multidimensioned.

To plunge into the totality of a thinking-imaginative activity is to enter a world too complex for immediate clarity. We must remain within the reduced limits of visual and auditory imagination—but even here there is more than enough to occupy us. In what form is imaginative activity a constant? We have not yet arrived at a clear display of the fields of imaginative activity, but now suspect that imaginative activity does display itself with some constancy even though that constancy, may often remain at the fringe.

Further variations without restrictions may be suggestive. And here I wish to make two claims concerning visual imagination that may at first appear strange:

1. Not all the structural characteristics of the perceptual dimension carry over to the visual imaginative parallel, and this in regard to their respective fields. My claim is that *the field space of visual imagination is similar in structure to the field space of auditory perception and not to the field space of visual perception*. The field space of vision is in front of the subject; but the field space of sound surrounds the subject. Thus for an entity to appear visually it must be in front of the subject or the subject must turn in such a way that it comes in front of him. But for a sound to present to a subject it may be anywhere and even fill the surrounding space.

Now turn to a fantasy variation within visual imagination: I may visually imagine a small red horse galloping on the floor behind me (of course I can also imagine myself seeing the horse there but this is merely to restate that imagination is *not* a perception). I seem to be able to place the visually imagined object in any position in relation to the *surrounding* imagined space. And if this is possible—let each try for himself—then the space of visual imagery parallels in a least one aspect the space of the auditory field and not its visual counterpart. In this sense the imaginative activity “exceeds” structurally its perceptual base.

2. A second oddity of visual imagination as such appears to be possible. Visual imagination may be “turned off” or “turned on” in a way not possible for the field of visual perception. Here I am claiming that one may not only “turn off” certain contents, but may turn off the imaginative field entirely *as a field*.

Perceptually, of course, we may open and shut our eyes and thus easily control the contents of what appears to us. But as we noted, this merely changes the character of the field without removing the field. If there is any parallel within visual perception to the absence of a field it comes not from the easy closing of eyes, but from the absence of the field entirely beyond the finite roundish boundaries of my vision.

(I would but recognize in passing that the imaginative habits of given persons may vary quite differently. But these variations of actual habit do not establish structures of limits of any given mode of experience as such.)

AUDITORY IMAGINATION

Do these same variations occur within the auditory dimension of imagination? Here at last we arrive at the primary topic of investigation and here at last we shall note both some general characteristics and some more specific features of the mode of experience.

As a field phenomenon auditory imagination apparently displays the same general features that its perceptual base does, that is, imagined sounds may be presented as coming from any direction or may surround the subject. Again the space of auditory imagination is *surrounding*. Note however that while the imagined sound may ordinarily be accompanied by visual imagery it need not be. An imagined sound may be “disembodied.”

Thus there is lack of surprise in the case of auditory imagination in regard to the similarity of perceptual and imaginative spatial structure. But a second feature of auditory imagination, if it is normative, is more interesting. *Auditory imagination, unlike its visual counterpart, is almost always continuous.* At first this may seem to extravagant a claim, but since the claim depends on noting several other facets of auditory imagination it may be well to wait until more evidence is in. Recall for the final time the difficulty posed by the focused attention in obscuring field or specific structures of experience. In the specific phenomenon I shall describe this is of greater than usual difficulty since the “thinking activity” itself tends to be involved with focusing itself.

With this warning in mind we may turn to variations within auditory imagination that will help isolate the specific phenomenon I have in mind. (1) It is immediately clear that auditory imagination displays the free variation of contents possible in all forms of the imagination. I may imagine, with or without visual imagery, voices of all kinds, an argument between two or more persons, noises of all types, music, and so on. Further, the range of sound, from silence to deafening roar parallels the auditory perceptual range. (2) This free variability allows a certain “control” over contents not possible in the perceptual mode. Thus while I may, within limits, select out certain sounds among others, perceptually I remain limited to the “passive synthesis,” which does not depend solely on my efforts. For example, if I am listening to an actual symphony I may focus on the strains of the oboe and make the “stand out” from the background of the full orchestra—but only within limits since I may fail to hear the oboe when it is covered over by the blare of the French horns. In imaginative fantasy, however, I present myself with the sounds in such a way that my control is “active.” This is not to deny that it is also possible to put myself in a receptive mood and merely allow sound images to present themselves as they will.

But these variations do not evidence auditory imagination as continuous since any particular instance of imagined sounds may be “turned off.” But these images do not exhaust the active synthesis of imaginative activity and it is to a narrower and more specific range of phenomena that we must look if we are to locate the form of continuity of auditory imagination.

AUDITORY IMAGINATION AS INNER SPEECH

The phenomenon I have in mind is that form of “thinking” that may be called *inner speech*. I believe this ordinary, though not properly investigated

activity, properly belongs to auditory experience in its imaginative mode. But to locate it properly several variations call for attention:

1. Inner speech is *linguistic* in character. We “think” in a language. Yet even this observation may go unnoted and for good reasons. First, we think *about something*. Once again our focus is directed in such a way we do not attend to the form of our experience in thinking. But also inner speech is a linguistic activity of extraordinary speed. It is a faster “speech” than actual or spoken speech.

Yet if we are asked simply, “What language do you think in?” we are quite quick to reply, “Why, English, of course.” The importance of a native language becomes even more clear when we set about learning a second language. For example, a common phenomenon in learning a second language is that of *inner translating*. In seeking to say something in a second language at first I have to translate “inside my head.” It is only much later and after much struggle that I learn to “think” in a second language. I have been told by experienced language instructors that even in the cases in which they are able to think in a second language it is usually the case that there remains a clearly primary and secondary language. Modern techniques such a “total immersion” that attempt to short-circuit inner translating are thus suggestive on several counts.

Even if we are now ready to accept the linguistic character of thinking this leaves us short of adequate evidence of its place in auditory imagination and short of establishing the almost constant presence of auditory imagination. But let it be clear here that the claim that inner speech is a normative mode of thought does not mean that thinking is exhausted by inner speech. There are too many obvious phenomena that cannot be included within an inner linguistic activity (such as the occurrence of “gestalt” insights, the “Aha!” phenomenon, in which a concept may only later be said. But even here it must be *said* if it is to become intelligible for someone else.)

2. We may come closer to the needed location if we note a reverse variation. Is it possible to “turn off” one’s inner speech? And if so under what conditions? It remains clear that the same shifting focus within a train of thought that is possible for any mode of consciousness occurs here. I may think along any given line; be interrupted and start off on another line; I may purposely abandon my thought and go on to something else. But may I turn off my thinking altogether? This is much less likely save in certain special situations.

A momentary “turn off” may occur in types of *shock* experiences. A loud sonic boom or a blinding flash of light may momentarily so shock me that my “thought is lost.” But such shocks or disruptions remain momentary and usually succeed only in starting off a new line of thought. Intense shock, however, disrupts not only thought but perception as well and the blank look of a person in shock indicates an abnormal discontinuity to consciousness itself.

There are, however, less startling perceptual occurrences that hold a special position in the disruption of inner speech and these are to be found in auditory experience. The suggestion of their importance is contained in the saying, “It’s so loud that I can’t hear myself think.” Noise, in filling the surrounding space of auditory perception, “invades” my being and in particular my thinking self. Control here is difficult short of stuffing my ears or actual removal of my presence from the source. This lack of control over auditory presence and the invasion of my very self was well recognized recently by a company perfecting riot control instruments. The most effective instrument, they claim, is a high-pitch directional sound that “hurts” the hearer even with his fingers in his ears. In the case of vision one may easily shut his eyes or divert his head to close off the offensive spectacle. With auditory perception control tends to be “psychic.” Thus the teenager seems to be able to do his homework to the noise of folk-rock. Yet it remains the case that if serious or concentrated thinking is to be done, it is usually the quiet place that is sought. Auditory perception intrudes into thought much more directly than visual phenomena.

3. But if perceptual experience may disrupt a given chain of thought it is much more likely to merely set it off in another direction. The same is the case with visual imagination. It is quite possible to either attend to a set of visual images or to let them come as they will, and some persons evidently have a more constant procession of images than others, but at the same time one may continue to “think” in the form of inner speech. Is this possible with auditory imagination? In this case it seems possible, for the first time, to *replace* inner speech. But it is replaced with an auditory phenomenon such as imagined music. Thus in both cases it remains that auditory experience is that dimension of experience that relates to, intrudes on, or replaces inner speech. But it also remains the case that there is a certain constancy to one or another form of auditory experience.

In the attempt to locate a quite common and perhaps predominant form of thinking, inner speech, within the realm of auditory

imagination, we have so far attended to variations on the broad spectrum of general auditory phenomena. A further set of variations, remaining within auditory phenomena, is also possible. In this case let us note several comparisons between spoken speech and inner speech.

4. Let us first restrict ourselves to some facets of speech for a single subject. It is the case, for example, that I hear myself speak. But this phenomenon usually remains on the fringe while the core of attention is placed on what I want to say, on “putting my thoughts into words” or as in this case one might say, “putting my inner speech in spoken speech.” (It is also the case that one may “think out loud,” in which case one merely “lets out” a free association of words much as one may allow images to flow before in imagination.) It is here that we note once again the relative speeds of spoken and inner speech. A part of the effort in speaking is directed toward saying what one is thinking but frequently falling short of the mark. I find that I have not said all that I have thought in a way similar to the note taker who cannot, because he does not have the skills of shorthand or speed writing, capture more than an outline of a lecture. And since there is, to my knowledge, no comparable way to transcribe the faster speed of inner speech into spoken speech and remain intelligible—the lag remains. Literary attempts to capture the “stream of thought,” even the excellent ones of a James Joyce, remain reconstructions rather than transcriptions.

But the secondary feature of spoken speech also contains some interesting features. When I hear myself speak I am at one and the same time the speaker and the recipient of the speech and so long as I remain in this double role I cannot hear myself as another hears me. Thus when I am placed in the second role, by means of a tape recorder, for example, it is not unusual to say, “That doesn’t sound like me,” since I have not before heard myself apart from *being* the speaking subject. Of course I may *learn* to recognize myself in the same way that a child learns to recognize himself in the more familiar mirror.

In other words, the sound of my speech is never heard first as “out there” as “coming from another source” but remains primitively related to the primary phenomenon of my focused activity in speaking. My primary focus obscures or covers over other features of my speaking. The same phenomenon occurs in inner speech but with greater obscurity. When I think (linguistically), my effort is on the problem or project at hand. I am the subject thinking primarily,

although I may secondarily recognize that I am using language in doing this. But it remains the case that thinking is *my* activity. Hence my inner speech, just as my spoken speech during the actual time of its occurrence, does not and cannot appear to me as “coming from elsewhere.” Rather it remains primitively identified with the thinking activity itself. This means that there is necessarily a phenomenological distinction between the representation of an imagined voice of someone else coming from somewhere and the imaginative presence of my inner speech. But both presences remain imaginative activities of free variation and both, I believe, properly belong to *auditory* imagination. Of course we must recognize that my inner speech, under normal circumstances, can never appear to me as a voice coming from elsewhere since there is no instrument capable of capturing it for me. (Some disruption, such as psychosis, may perform this. In such an abnormal case, however, it is quite likely that hidden in the mystery of the body there is something “physically” askew.)

5. Note finally that inner speech as an auditory phenomenon in the imaginative mode may again portray a general feature of auditory space. In concentrated thinking, for example, thought in the form of inner speech may appear to *fill* the consciousness. I am “engrossed in” my thought; it surrounds me—just as auditory space surrounds me and may, in the striking sound of a symphony, fill my being.

Inner speech, then, as a very important facet of the thinking process and probably the central form of that process, displays the features of an auditory imagination. It is a free variation that presents itself as *my* activity in the form of language. It ranges from a fringe phenomenon in the cases of concentrated efforts on projects in the perceptible world to a core phenomenon in the cases of concentrated thought. Its “spatiality” is that of auditory space that is or may be surrounding and may or not be accompanied by other forms of imagination. And it is this visually imageless or latently visually imageless activity that presents itself as its own type of totality that remains an almost constant dimension of experience.

SUMMARY

At the end of this preliminary and at best suggestive chapter it is perhaps appropriate to acknowledge that to this point I have not gone beyond a phenomenological psychology that itself remains incomplete. I would,

however, like to suggest that the suggestions of such a phenomenological psychology may hold some significant clues to philosophical problems. Thus before leaving the area of auditory phenomena as one important dimension of our experience of the world I should like to indicate a few areas in which just such a phenomenological analysis may be of use: (1) It is not without consequence that a seeming predominance of visual metaphors has been used in the history of philosophy even in relation to our thinking activities. Phenomenology as well has frequently relied on visual metaphor to describe such activities (*Wesensschau, Sicht, Abschtungen*, etc.). Yet visual metaphors, if inner speech constitutes any important dimension of thought, are inadequate to the phenomena themselves. (2) Already implicitly recognized but not investigated either here or elsewhere with sufficient study is the relationship between our experience of time and auditory phenomena. It is not without reason that Husserl should have used musical occurrences to illustrate the inner time consciousness. (3) In a different area, the insistence of analytic philosophers on the privileged position of language as a philosophical problem is not without merit. If, concretely, inner speech as an almost constant auditory imagination is to be understood as language, then the relationship of language to perception, for example, needs much further examination. (4) The currently much discussed problem of other persons also should relate to an examination of auditory phenomena. In spite of the fact that in this discussion much is often made of how we might be fooled by a good robot, the predominant way in which we come to recognize and understand another remains linguistic in the quite concrete phenomena of speech (and secondarily in writing, which is a visual derivative). For example, if I am present to myself in thought, which has the form of language, this remains an imaginative inner presence, which has its perceptual counterpart in the speech I hear of the other. Thus in this case language becomes the intersubjective appearance of the other to me and of my innermost thoughts to myself.

The essay, at least, represents a call for further investigation of auditory experience and the role it plays in our experience of the world prior to too-quick conclusions about higher functions of human speculation. It is latently a call for a full phenomenology of sound within the limits of a Husserlian “regional ontology.”

This page intentionally left blank.

Chapter 19

Listening

The researches that lie at the origin of the essay were conceived of in a seminar on the phenomenology of perception in which auditory experience was to be of particular importance. The aspect of auditory phenomena we choose to describe here relates to a phenomenology of listening to music. The problems that arose in approaching music revealed interesting questions about comparative types of phenomenological methods.

In brief, the task of attending to music began to show a difference in emphasis between the use of “Husserlian” as compared to “Heideggerian” phenomenologies. In the Husserlian version the emphasis is on positive attention to the phenomena. This positivity, described in the literature as the “ray of attention,” “focusing,” and so on, gradually betrayed more and more basically visually derived metaphors as the favored means of getting at experience. In contrast, the Heideggerian emphasis on “letting be,” the insistence that the phenomenon “manifest itself from itself” could be described as a negative means of attaining what is sought for by a process of gradually excluding irrelevant factors. An auditory metaphor lies behind this version of phenomenological reduction.

We shall seek here both to increase the contrast of methods and to describe the results by which we found a Heideggerian approach more and more appropriate to the problem of listening to music. Several words, however, are in order concerning the context of the seminar. First, it was presumed from the basis of the prior research that the investigation of

auditory experience, particularly when compared to studies and illustrations from visual experience, was a relatively underdeveloped field of inquiry and examples. We found through an investigation of the literature in relation to psychological experiments in perception that this generalization was clearly supported. Second, the use of visual metaphors in the language often tended to create a tradition of interpretation which, in the Heideggerian sense tended to hide or “cover over” (even the Heideggerian use is often visual in its metaphors) the phenomena. Thus as a device by which traditional assumptions and interpretations could be located and possibly removed, the seminar proposed to attempt descriptions that would at least point up the use of visually related terms or at most use a language that would avoid such terminology.

Both these warning factors are, of course, related to a type of phenomenological reduction whose purpose is to remove assumptions and presuppositions but not to reduce experience. The phenomenological reduction is supposed to clear the field for description. The steps of this process and the attendant problems are reported below.

EPOCHÉ: ORDINARY EXPERIENCE AS THE LEVEL OF CLICHÉ

First attempts at description without instruction or carefully worked out approximations are frequently frustrated due to the tendency of mere description to yield *traditions*. In the case of music such traditions include the use, as description, of both previously formulated conceptual schemas and ordinary common sense comments. “I hear an octave,” or, “that is a chord composed of A and F,” are examples of statements that may mistake a conceptual classification for direct description. “That is a loud noise,” or “That’s screechy,” are examples of the ordinary response prior to phenomenological reduction.

This state, which is usually the result of pre-phenomenological demands for description corresponds to the problem of the “natural attitude” in the Husserlian context. Mere description confuses categories and may do so to the extent that a classificatory scheme is taken as the phenomenon itself (a similar case of such confusion exists when persons say, “I see images on my retina”). Thus a clearly directive question must be posed and posed in such a way as to give shape to the inquiry. In Husserlian terms the “natural attitude” must be replaced by a “phenomenological attitude.” This displacement is the framing of a question addressed to the phenomena in question.

But this is also to say that the phenomena do not just “speak out” themselves—they “speak to” a question addressed them. One’s *project* sets the context and is already a preselection concerning what may occur within the context. In this sense and to this degree *epoché* is also interpretation, but the more serious question is one that concerns the significance or additional yield possible through this interpretation.

The framing of the question, however, may be understood in at least two ways. In the Husserlian emphasis the direction is one that seeks to *focus* attention on the phenomenon. This is a matter of placing limits on other aspects of experience in order to concentrate on that which is sought. The Heideggerian emphasis is, to a certain extent, an inversion of the former insofar as the gaining of the phenomenological position is one that successively opens one to the emergence of the phenomena “from themselves.” However, in the early stages of the descriptive process both methods require a set of progressive reductions toward the phenomena. In the Husserlian interpretation this is the progressive bracketing of presuppositions; in the Heideggerian hermeneutic it is the gradual loosening up of calcified interpretations.

PHENOMENOLOGICAL REDUCTIONS: RELOCATING DESCRIPTIONS IN ORDER TO GET TO UNNOTICED ASPECTS OF THE PHENOMENON

The first steps in getting to the phenomena turn out to be directed away from immediate experience and toward making interpretations stand out in such a way that their distinction from the phenomena become evident. This is already implied in the failure of *mere* description. In the case at hand the pointing up of conventions about auditory phenomena that use visual metaphors provided the vehicle for this separation of phenomenon and interpretation. We found, as one might suspect, that these traditions are so integrally bound to our ordinary descriptions of auditory experience that we take that experience for granted without seeing how or whether our descriptions are justified.

In the language *about* auditory experience we found an abundance of (visually) spatial terms. Sounds are “movements,” there is “up” or “high” and “down” or “low,” and so forth. More significantly in relation to music, we noted that in musical theory and musical training the conceptual scheme is again one dominated by visual metaphor. For example, one is trained to conceive heard impressions as “distances intervals” or a “leap” of an octave,

and musical notation (in the Western tradition at least) has rationalized a conceptual scheme that is thoroughly based on spatial analogues. All of this may be noted without ever inquiring into experience. The phenomena have not yet “spoken” to either confirm or negate the conventions about them. But in making ourselves self-conscious about the traditions as traditions a question begins to take form in relation to the experiences we were after.

Is it self-evident that “movement” is a primary phenomenological characteristic of music presence? Is musical experience “spatial”? What does experience “show”? Or, if the answer confirms the visual-spatial characteristics of the experience of music, how does this occur? Methodologically, now, we are at the juncture where the comfortable assumptions afforded by ordinary awareness are called into question and the phenomenological shift is one that demands that experience “speak” in a new way. We are aware, of course, that this shift is one that purposely and “violently,” if we use the Heideggerian notion, displaces the familiarity of the ordinary.

Once the conventions concerning music are called into question the experience of listening must be described from the implied “new” basis. In our first investigations it did not seem that spatial characteristics were integrally related to musical presence at all. Music’s “movement” does not occur spatially. Its mode of presence carried its own uniqueness. But at the same time we found that a description that would totally avoid spatial imagery was difficult if not nearly impossible. Here, although we found the usual frustration of phenomenologists regarding the “limitations” or “restrictions” of language to be apparent, we also found that a rearrangement of spatial considerations helped to point up unnoticed characteristics. Thus as we begin our descriptions we note that we remain “conservative” in the sense that we do not attempt a total rejection of the dominant visual-spatial imagery. What follows is a series of examples, “perspective variations,” which lead us ever more deeply into Heideggerian notions in relation to listening.

One place in which the greatest “distance” between the direct experience of listening to music and the classificatory scheme seemed to appear was in some of the relations between the Occidental notational system and the experience of what is heard. In this classificatory scheme the octave serves as a basic unit which, in its visual model, shows the interval of the octave as the greatest distance and all other intervals expressed as lesser distances.

But auditorily the case is quite different. To hear an octave the two notes which frame the octave are present as “close” or having no sense of “movement” or “space” between them. Distance in terms of conflict, for example in atonal combinations, would seem more appropriate for “distance” notations.

But this is too “conservative” because the mere rearrangement of the spatial metaphors also shows its inadequacy. Again, in relation to bass figurations “wide” intervals are often used and the octave is frequently one of these. Yet in listening this “jumping” is not a dominant characteristic of the bass line—it is heard as a “smooth” undergirding of the music and is comfortably integrated into it.

In fact, one must be thoroughly trained to recognize the “spatial” characteristics of sound. Initial listening exercises disclose that one does not naturally hear an interval as a given “size” or “distance.” The association of the space of a fifth, a sixth, a third, with the appropriate sounds is learned. And even after some degree of training it is possible to mistake a fifth for an octave and it is often difficult to tell whether an interval moves “up” or “down.” The spatial scheme is associated with—or perhaps imposed on—the experienced sound. Here the temptation in ordinary description to confuse the music with its notation is much like the linguistic problem of confusing language with its reference. The distance between the notational system and the experienced sound is in fact complicated by a third factor. A total musical theory lies at the base of musical notation and in our tradition that theory is one which from the Greeks based on mathematical interpretations of musical phenomena. Thus hidden between the notation that often gives up our spatial metaphors concerning experienced sound and the experience of sound is a vast schema of “mathematizing thought.”

But it is time to turn more directly to noted characteristics of listening to music. One of the first aspects that began to stand out in relation to this phenomenon was the *fragility* of the musical phenomenon. Within the global field of auditory phenomena, sounds of all types are present. This very fact complicates and acts to the detriment of musical presence. It becomes impossible, in ordinary contexts, to secure an exclusive focus on music because of the global presence of sound.

From the Husserlian interpretation this failure of total focus might raise some questions about the possibility of even getting to “the things themselves.” But from a Heideggerian interpretation other things may be noted. For example, imagine a living room in which a stereo set is playing. By first attempting to concentrate as exclusively as possible on the music we become aware that a manifold of other noises *intrude* on this project. Our very project makes these noises explicit in such a way that from their previously ordinary presence we now discover they have been implicit. The focus of attention upon the music makes the other noises appear as distractions—but they also stand out in more vivid fashion. In attempting to listen to music for itself we become more rather than less sensitive to introducing

noises. As purists each minor distraction becomes apparent, each scratch, each external noise distorts the music itself.

This fragility of music increases in direct proportion to the concern of attention “toward” it—and paradoxically the fringe noises of the environment begin to benefit from the attention toward music presence. Auditory phenomena *intrude* into my awareness. This specific experience, however, also begins to point up a more general feature of auditory experience. In our familiar immersion in a sound world we live with sounds that pass for the most part unnoticed as the iceberg that passes mostly submerged.

What is to be noted concerning the above phenomena is that the previously submerged noises do not intrude as a result of gesturing “toward” them. In the auditory realm our focusing, which should effect an exclusion, negates itself and produces the contrary effect of increased vulnerability in an increased openness to the environment’s total presence. Not content with the situation, we begin to notice a series of exercises designed to correct the problem. These exercises, which may be called the “Shh—be quiet!” phenomenon, begin to indicate the direction of auditory gesturing.

For example, if one wishes to itemize the auditory environment a positive act is one which gradually or suddenly calls for more and more quietness. One gestures “away from” sound “toward” silence. And the more effective this gesture-direction becomes, the more one realizes silence, the more radical the intrusions of formerly unobtrusive auditory disturbances become. The penultimate case occurs when one enters a well-constructed echo chamber that has been so built as to eliminate sound reverberations. He finds that two tones *intrude* into auditory consciousness, one higher than the other. The physiologist will tell the observer that one is the flow of the blood stream and the other the “current” in the nervous system—both of which had been unnoticed and unheard before.

Of course, to hear best one calls for relative silence. Nor is it simply a matter of receptivity. Lecturers and actors on occasion speak softly for emphasis and the most arresting sound is often subtly minimal as the “still small voice” of the biblical God. This arresting characteristic of soft sound approximates or is a gesture toward *silence*. The concentrated attention-direction of listening is a gesture toward silence.

Artificial devices, earphones for stereo music, heighten this aspect of listening. Earphones do not so much make the music better as they shut out extraneous noise—this device enhances the sound of music by securing an accompanying silence. Gesturing toward silence enhances listening.

Here the Heideggerian model again makes its appearance. The horizon of sound is silence, but at the same time it is the “absence” that is never

attained. To suggest that silence is the primordial ground of music may seem abstract at first—but we contend that the gradual realization of this aim for listening may sharpen the listening experience. Silence is the unspoken background for sound.

It is here that one may begin to return to the problem of language in relation to the descriptive attending to music. Silence is the “space” of music. The “motion” that occurs in music is the motion through silence. In (visual) space, movement is a matter of displacement, relocation, or “matter” that is always someplace, comes from someplace, and goes somewhere. In music sounds come “from silence” and “return to” silence.

This is not to say that the coming-into-being and passing-from-being of sound is irrational. For example, in listening to music one begins to anticipate the expected sounds. There is a desire to hear additional tones and for those tones to be well related to those before. But our concern is never whether or not there is “room” for that tone. Here we reach one possible rationale for the appeal of music. In the musical world as perhaps in no other it is possible to create something from nothing.

Even the listener in the case of the recorded piece has the possibility of rejecting the music by lifting up the arm of the player. In this act lies the power to make a particular strain of sound stop. But higher in the scale of creation lies the sheer potentiality of silence. Through the creation of music humans can manipulate the mysteries of being and becoming, of actuality and potentiality, and through the vehicle of music they can legislate the schedule of a phenomenon’s passage from its total being to its absolute annihilation. In the tones of music the “matter” of sound waxes and wanes at the player’s discretion. And when it passes there is no residue. The conservation of matter or energy does not apply here. At base this coming-to-be from silence from which music stands out shows the “space” silence of sound as possibility. Silence is nothingness but nothingness is sheer possibility. This Heideggerian expansion from musical phenomena is one which in turn points back to that methodology. In the Heideggerian model, with its concepts of “call,” “silence,” and the “voice (of conscience),” the fundamental thing that occurs is a thinking with roots in auditory metaphor. And to follow the implications and pathways from that metaphor as a shift from the traditional visual metaphors of our philosophies may open a new direction for Western thought.

This page intentionally left blank.

Part VI

Acoustic Technologies

This page intentionally left blank.

Chapter 20

Bach to Rock Amplification

Followers of the McLuhan style of thought concerning the influence of media often point out that the invention of high-fidelity recording is to music what the printing press was to writing. Just as books from a printing press became both easily reproducible and inexpensive and thus created the conditions for a wider literate culture, so inexpensive and widely available recordings create the conditions for a wider musical culture.

But is recording to music what printing was to writing? My answer is that in the deepest and broadest sense it is—but precisely because it is, some unexpected changes in musical culture may be expected. My thesis has its roots in both external trends and in personal experiences that have become more dramatic in recent years.

An external symptom is found in trends concerning classical music recording sales. Market analysis indicates that this class of music sales has not only remained stable in an otherwise expanding market, but that its customers are growing older. This, say the analysts, indicates that youth are not being converted to classical and “serious” music.

At first I was inclined to think little of this problem, perhaps allowing myself the opinion that this is about what one could expect in the light of basically unimaginative public music education. Record sales probably showed the same tendency for mediocrity and a lower denominator as commercial television (also I thought myself to be a musical “elitist” at heart). I now regard this prejudice as false.

It takes little reflection on the wider musical situation with youth culture to note: (1) that it is pervaded by music to a degree seldom achieved by earlier generations. Youth is very much “into music.” Music is so pervasive, in fact, that it has become a symbol within youth culture. The mass gathering of the rock festival, the omnipresent music technologies in dormitory rooms, and even the occasion for the first riot in a National Park when oldsters and guards at Yosemite objected to an informal rock session, all center in musical events. (2) Although some might debate the absolute worth of youth music, it seems to me that much of youth culture’s music is significantly superior to that of the swing-ballad era of my youth. Youth culture’s music is considerably varied in style from folk to country to rock; inventive in hybridization, folk-rock, to all other conceivable combinations; culturally open, Asian influences to revivals of strains of classical instruments such as harpsichord and lute; and is purposefully experimental in contrast to much earlier program-produced “pop” music. (3) Moreover, youth culture’s music is largely indigenous and I suspect much of the improvement comes precisely from the overthrow of the select group of formula “professionals” who dictated the style of earlier radio and record productions. The music of youth culture has invaded the wider cultural scene. “Adults” now play everything from the Beatles to punk as well as youth.

If the above is the case, one could already point to a general parallelism between the introduction of recording and the earlier introduction of printing. The wider universalization of music, the proliferation of styles, and a democratization of the music-making process, are all analogous to what happened at the dawning of the “Gutenberg era.”

But these general parallelisms do not indicate why, within the proliferation of styles, classical music has apparently been shunted aside or relegated to a minor role. If youth culture is musically more healthy than it was two decades ago, why is there not an increase in or even stabilization of classical music appreciators among them? The answer, in part, lies in something occurring within youth culture itself. On inquiry many students who are seriously interested in music will also respond that classical music is “head music” while their music is “body music.” Is this merely to assert a prejudice for rock over Bach? I think not, rather it has something to do with a relationship between musical experience and its concrete embodiment in reproduction.

I recognize here that by turning to personal experience and generalizing on it I risk being speculative at best—however, what I outline below has apparently also been a common experience. When I first acquired a high-fidelity stereo set as a graduate student, our first record purchases were all of the “serious” variety with special emphasis on baroque, particu-

larly Bach and Vivaldi. In ecstasy I would listen to the disciplined, artful, magnificence as this music filled the room and my consciousness. However, it took little time to note a flaw—the more I entered into the music the more I became aware of auditory distractions, particularly those from the set itself. Any scratch, any barely audible hum, any interference became annoying and threatened the enchantment of the experience. Even more dramatically I noted, each time I went to a concert, how much “purer” the actual live performance was.

The music demanded *purity* of sound, and reproduction, no matter how good, always remained short of this live purity of the concert hall or chamber. I am claiming here that the *context* in which the music developed historically turns out to be more important than it might at first appear.

Over the years my record library expanded and my wife and children exerted their influences and tastes as well. Music was played to fit—and sometimes to create—the mood. Many occasional evenings were spent not merely listening but dancing expressively to the stronger beats of Peter, Paul, and Mary, Joan Baez, and the Victory Baptist Choir. Later, Country Joe, Cream, and Jefferson Airplane were introduced and I began to discern on the edges of my consciousness the difference between “head music” and “body music.”

The difference is not one of mere volume or of strong beat—although both are elements of the musical demand of youth culture music. More holistically I would say that rock and its relatives exert a call that orders either rejection or participation. It is too noisy, too insistent to be ignored. It is “either/or.” The music in this sense demands a “conversion.” Its call is enticing and vibrant. Its dynamism is such that after some listening it is no wonder that Bach seems so “tame” by comparison. Youth music is seductive within its very noise.

The difference between “head music” and the seductiveness of “body music” is not one of complexity compared to simplicity. Both have their own styles of complexity and within the respective genres examples may easily be found illustrating a range from simplicity to complexity and from good to poor quality. One must learn to listen to each if the lesson of the music is to be learned. Rock almost always appears to the beginner as “noise.” But *within* the noise music occurs. The first time I listened to Cream, its noise and its repetition were the only factors I could discern—amplified musical paganism. Later it became domesticated and the repetitions receded to the background against more subtle modulations that filled the foreground. (I have not, neither do I intend to attain the quasi-mystical state reported by the “true believer,” which in the presence of the fully amplified piece, the loudness so near the pain threshold, a kind of “silence” is reported—although I believe I can recognize that experience

as an extension of what I already know. In this extreme state, however, the cilia of the ear are eventually damaged. If so, the “conversion” to rock becomes permanent in a sense because the more delicate sounds of “head music” would be forever lost to the hearer.)

There is a third factor that began to emerge in listening to the “harder” types of “body music”—the search for purity experienced with classical music is lacking. In fact, instrumental tonal purity is irrelevant here. The sound of rock begins electronically, reproduction and amplification are a part of its very embodiment. Thus the process of electronic reproduction does not get in the way—the music is itself an electronic creation. I am suggesting that just as the live performance of chamber or concert music is the medium, the historical and actual context in which the classical form of music developed, so the transistor and the amplifier are the context of the harder forms of youth culture’s music.

The differences that emerge between “head music” and “body music” are easily felt, but somewhat difficult to express. Part of the problem is found in the actual use made of the difference within youth culture. As used there are two meanings that are not equivalent. The first is a deprecating meaning—“head music” is music that is composed. It is music that youth culture believes is mechanically created according to a theory or “science” of music, whereas most forms of youth music are thought to be more subjectively expressive and spontaneous. This semiromantic notion of “body music” repeats a common theme of youth culture: whatever is expressed must be genuine and personal. Here the negative valuation of “head music” is both anti-intellectual and yet potentially creative.

The anti-intellectualism is merely naïveté. Surely many composers of one, two, and three centuries ago deeply *felt* their music in spite of composing within an accepted idiom and, contrarily, one can also point out that the nascent romanticism of subjective expressivity and spontaneity is also an idiom that has its own “laws.” But the anti-intellectualism, even if uninformed, does have a functional role. It allows the new idiom to emerge. The movements of the history of thought, in music as well as in other areas, seem to be accompanied by iconoclastic polemics against previous forms. The polemic often is the tool (and sometimes excuse) for sharpening the edge shapes of the new tradition and form.²

But more profoundly and genuinely the difference between “head music” and “body music” is an attempt to express a difference in the felt response to the two types of music. There is a sense in which the common meaning is too gross. All music listened to seriously is some kind of “body music”—one hears not with ears alone, but with one’s body. The Bach fan, listening with closed eyes to the musical presence of an excellent fugue

experiences a set of bodily tonalities that “move inside” him. He may feel an inner sway to the beat and rhythm, a chill to certain passages, and be “filled” with the music. He is listening with his body. But in spite of that one must characterize the felt bodily response as properly reflective of the music itself. These tonalities are restrained, measured, and as it were, controlled.

There is even a sense in which the bodily focus, though distributed throughout the body, is more often focused higher in the body itself than with rock. And this provides a clue to the emphasis within “body music” as used within youth culture. Rock, too, is heard with the body. But the insistent demand of the music resonates, almost against any will of the listener, “inside one.” I find that the focal location of the rock response is often lower in the body—the bass notes are felt in the chest and stomach—even though, again, the music resonates throughout the whole of one’s body. At the extremes of amplification where the quasi-mystical trance of pain-sound occur, it becomes almost literal that one hears more with the body than with the ears (head).

Rock is the celebration of amplification and the electronically embodied instrument. Even the voice is “electric” through the use of echo boxes and the deliberately created “distortions” of rock singers when they hold the mike to their lips or wave it in the air. The *body* of “body music” is electric.

A more precise parallel between the history and development of recording and printing now emerges. When the printing process was young, it first imitated the familiar hand-produced script. Early printing used gothic letters, was elaborate, and expensive. Its stylistic paradigm was extant hand-script merely transferred to the new process. Only much later did the potential of the press begin to be realized—the development of the sparse, simplified, and easily read letters of modern typescript grew out of the potential of the medium.

Contentwise a similar process followed printing. The Protestant Reformation saw in the press a means of radicalizing religious culture. Luther’s “German nightingales can sing as sweetly as Latin larks” was an insight into the culture-transforming power of the dissemination of the (printed) word. Printing only gradually expanded from Bibles and theological tracts to business accounts and advertisements.

In a faster time period the same developments in recording may be seen. At first what had always been heard was re-produced, whether the sound of big bands or Mozart. Later came the demands of the medium itself. Amplification, electronic sound, becomes its own instrument. Reproduction becomes production. And, not to stretch the point too far, the “revolutionary” implications for culture within youth culture’s music are not too far disjunctive from the radical potential seen by Luther’s demand for cultural change.

But in the process, just as Latin and gothic script—remaining beautiful, artistic, and to be appreciated—began to recede as the main style of the “Gutenberg era.” Bach becomes more clearly “period,” more museumlike in the perspective of youth culture.

I am not prophesying the death of Bach. But if the printing-recording parallelism holds, it does mean that Bach will have a harder time in the future. There will remain “two culture” people, just as in the present omnipresence of television, reading continues to hold its own (unless, ominously, those members of youth culture who claim having “transcended” literacy win the day).

Neither am I prophesying the eclipse of “serious” music. The innovative movements of the twentieth century, from the explicit development of new electronic instruments, to computer composed music, to experimentation with atonality, to the contemporary movement within the arts to make whole fields—in the case of music the field of sound—of experience a kind of “art,” are all parts of a general movement symbolized by the “Bach to rock” example I have developed here.

These trends and the experimentation within the “new music” may not yet have found their proper voice. Much “serious music” is still hampered, in the view of youth culture, by an overly metaphysical-theoretical mindset. It has not allowed the electronic instrument to reveal its own style. But just as gothic frillery in the first steel buildings disappeared, so will the new genre gradually be purified of the past so far as it is unnecessary.

What I am indicating is that within the symptomatic shift in *musical technology* a deeper shift of sensibilities is also going on. The McLuhanites are at least partly right in labeling the era an electronic one. The “electric” is a new—but I suspect transitional—*symbol* for the shift in sensibilities. We tend to mold our concepts of ourselves upon our concepts of the world. Our active and operative “myths” that contain this self-world interpretation function in terms of key symbols or metaphors. In an “electric” era we model our minds on the electric computer. The cinema, another electric creation, has become so pervasive in the way in which we have begun to understand ourselves that even psychological literature has begun to liken our dreams, our fantasies, our visual imagination to the “movie-like.”

The “electric” world is a world of “flow,” its images are suggestive of transmutation, transformation, and the melting of distinction. In music, again particularly among youth, the whine and microtonic “flow” of the sitar and the “electronic instruments” “infinite flexibility” embody the flow of the electric. In cinema the flow of images magically transforms our seeing so that images melt into one another and transmute the entities of the screen in such a way that the “metaphysics” of ancient demonology and witchcraft become real within the possibilities of film.

The “electric flow” image of much contemporary culture is in contrast to the mechanical, the clear and distinct atomism of the recent and perhaps still dominant past. The change in sensibility is symbolized by the shift from “mechanical” to “electric.” The world becomes “Heraclitan” before us rather than “Democritean.”

But the McLuhanites are wrong when they tie this shift of sensibilities to a shift from one to another dominant sensory form. They have almost convinced us that the era whose presence they see slipping into ancient history is one that is *visualist* in sensory form. For them vision is the paradigm sense that gives us the mechanical, the clear and distinct differences, the atomism of a “Democritean” type. The electric era, they say, reintroduces an *auditory* imagery based on *flow*, the melting of differences, the emphasis on motion—the “*flow* of the electric.” Television, records, radio all destatify us by returning us to a more auditorily oriented culture.

Historically they have a point. The early scientific literature did emphasize much *visual metaphor*. It did utilize measurements that were necessarily embodied in spatial-visual forms. The “ideal observer” as the limit idea around which Newtonianism revolved was metaphorically a looker at a silent world of mechanical motion.

In all of this, however, the reduction of early modern scientific culture was *not so* much a reduction *to* vision as the McLuhanites hold, but a reduction *of* vision. What is needed is a reevaluation of the full range of possibilities within sensory experience. In fact the metaphor of the “electric flow” has already begun to transform our vision itself. The cinema and television have already begun to teach us that vision *flows*, blends, transmutes and transposes. And contrarywise, we ought to learn within musical experience that hearing can become keyed to the accurate tone, to precision, to clear and distinct differences. It was—precisely in the perfectly beautiful, if “mechanical” sounds of Mozart and Vivaldi.

Merleau-Ponty has understood more profoundly that “perception itself is polymorphic and that if it becomes Euclidean, this is because it allows itself to be oriented by a system.” If both vision and hearing today become attuned to the potentials of “electric flow” it is because our perceptions are concretely situated within an emerging metaphor, a newly oriented system.

Beneath the shift from Bach to rock lies the more profound shift of metaphors and sensibilities. Its embodiment lies in our *technology* and its relation to polymorphic perception. If today we have just begun to hear the world in a different way it is because we have already begun to exist in the world differently than before. The intellectual task, philosophy’s fundamental thinking, is to begin to make that shift more apparent and to discern its genuine as opposed to its inauthentic possibilities.

This page intentionally left blank.

Chapter 21

Jazz Embodied Instrumentation

VARIATIONS ON HISTORIES, REAL AND IMAGINED

Early modernity is said to have originated in the seventeenth century and one of its much later named practices became “science.” We would not have a problem thinking this early science to be occurring when Galileo turned his newly fashioned *instrument*, the telescope, on the heavens. And, thus when he discovered—and quickly publicized—the observation that the “star,” Jupiter, had four “planets” circling it; we have no trouble calling this a scientific discovery. And, he also noted that Saturn had some sort of “protuberances” around it, but given the capacities of his early telescope he was unable to resolve these protuberances into rings. But, if we turn to his practices—which included rapidly developing and improving his telescopes (from 3 power to nearly 30 power during his life); having to learn how to focus and not wiggle the scope about; having to learn to interpret what he was seeing; and eventually arriving at a peak performance given the instruments—we suddenly come upon an interesting parallel with another set of practices: playing music.

In our quasi-imagined history, we might miss the important fact that just as what was to become “science” in the modern sense was the discovery of things via the mediations of instruments, what became opera, “classical,” and then later romantic and other versions of our standard Western music repertoire, also owes much to its embodiment to Renaissance

instrumentation. The move was from the primarily vocal only sacred chants, into the instrumentally embodied musical groups, both sacred and secular, of the Renaissance. So, we could now substitute for Galileo and his telescope in Italy, a move to Elizabethan England, we see the beginnings of an instrumentally embodied music. One Martin Peerson breaks from the dominantly vocal or vocal and organ traditions and recommends a *keyboard* accompaniment to the singers and even adds viols and lutes. Again, focusing on practices, one can see that the instruments had to be developed, learned to be played, and finely tuned to produce a virtuoso performance—only here it is musical sound rather than celestial new vision that is being “instrumentally” produced. I am hinting, of course, that the technologization or the embodiment of practices in early modernity belongs both to music and science—it is part of the beginnings of the modern age.

If this early development of “science” compared to early European music seems parallel insofar as the human performers (scientific observers/musical performers) learn to use and take up “technologies” (instruments) to make their productions (heavenly phenomena/musical sound), a rather curious dissimilarity arises if we now do the same comparison for contemporary science and music: If, today, we asked certain questions about the makeup of Saturn’s rings, the instruments that reveal the small bits of ice and rock, layered into multiple rings, are shown by extremely high-resolution telescopes, or even through photography from a space probe flyby. *No one would dream of making a scientific performance today by going back and borrowing Galileo’s instruments!* Yet, we also do not think twice about going to a concert of Renaissance music, still performed by ancient, and indeed the more ancient the better, instruments. The two practices make a radical divergence in this example: new science must use new instruments; music production need not do so.

THE TECHNOLOGICAL CONSERVATISM OF JAZZ

As much as jazz is thought to be progressive, it does so musically by enhancing and forefronting improvisation, often following musically a parallel to oral traditions (not always or sometimes never annotated). Its cultures from which musical practices come are often non-European, and its tight social relations are those of the band or group. And I want to note that this new music is itself *multicultural* (African, Caribbean, American). This “new,” at least twentieth century, musical practice emerged and soon spread from its places of origin (largely the United States) to the world, and to Jazz House, Copenhagen. But, if we take the variations I have just suggested and

apply them to jazz; the instrumentation within the jazz traditions—not unlike many other musical traditions—remains “technologically” conservative. If Dizzy Gillespie’s upturned horn bell is innovative, it is more so for show than for musical quality. And, admitting the mix of instruments often differed from other musical groupings—more banjo, dominant brass, and of particular interest, the forefronting of the saxophone—until very recently, jazz players do not seem to have been very powerful in introducing new instrumentation.

As I have suggested, this technological traditionalism is common to many types of musical practice, even the innovative ones, although there have often been histories of technological *evolution* to instrumentation: the familiar harpsichord to clavier and pianoforte to the contemporary piano illustrates this. Many instrumental types—horns, from which we get trumpets, trombones, basses, and the like; or stringed instruments plucked or bowed, such as lyres, harps, lutes, violins, and so on, go back to antiquity with recognizable ancestors displayed in bas relief in classical Egyptian times.

THE SAXOPHONE

The saxophone is one of the rare “modern” instruments in the sense that it was designed and built by an individual, Adolphe Antoine Sax, around 1840, with explicit design intent. Sax wanted a wind instrument with greater power than the usual woodwinds, but retaining their expressivity. He was quite aware of the technical parameters, which sometimes meant that strings were too weak, and even woodwinds overpowered by brass. As saxophone historian Sigurd Rascher says, “He dreamed of an instrument that would, through its total characteristics, bridge these gaps” (Classic Saxophone On-Line, www.Classicsax.com). With the hybrid combination of a reed mouthpiece and a brass body, he achieved, in part, his aim. It is to be noted that, like many science instrument makers of earlier modern times, he came from a family of instrument makers and had the requisite tacit skills for making refined instruments.

Although not immediately successful in introducing the saxophone in Belgium; he trekked to Paris and was able to convince the then most prominent musicians (Rossini, Berlioz, Meyerbeer) of its “beautiful sound, priestly calm, pontifical dignity” (ibid. *Classicsax*.) Berlioz even published a newspaper piece extolling the new instrument: “Its sound is of such rare quality that, to my knowledge, there is not a bass instrument in use nowadays that could be compared to the Saxophone. It is full, soft, vibrating, extremely powerful, and easy to lower in intensity . . . the character of such sound is

absolutely new, and does not resemble any of the timbres heard up till now in our orchestras . . ." (ibid.). Then in one of so many predictions concerning technologies that turn out to be wrong, he added, "Naturally, this instrument will never be suitable for rapid passages, for complicated arpeggios; but the bass instruments are not destined to execute light evolutions" (ibid.).

Adolphe Sax did not simply let the bass sax stand, but produced a family of saxophones, bass, alto, tenor, and so forth and was successful in not only getting well-known composer's orchestras to adopt the instrument, but the French military bands that soon learned to like its brassy sounds as well. Yet, in the nineteenth century, the saxophone also remained a background instrument, in part because the musical culture itself was often resistant to change: "In France the saxophone has often been used in orchestras, but it could never assert itself, because musicians are slow in accepting anything new." (Ibid.). The early sax remained "mellow" and in the background.

The jazz-informed reader will anticipate the next chapter—with the turn of the century and the introduction of loud dance music, the sax became a foreground instrument, loud, brassy, assertive, and now playing precisely the rapid and difficult arpeggios previously predicted to be impossible. And, by the 1920s Paris had become the prime producer of embossed, fancy saxophones dominated by the Selmer Company from the 1920s to the 1940s. But, the instrument itself had also changed—it had received a bigger reed mouthpiece, got bigger bells, and retooled keys—all making its now expressive and powerful sounds that take their solo turns within the jazz genres. Here we have something approaching the symmetry suggested by Bruno Latour, who argues that the humans and nonhumans transform each other.

MUSIC AND SCIENCE REDUX

I return to the instrumental parallelism between science and music. The microhistory of the saxophone suggested shows that both within science practice and music practice, the shapes of instrumental embodiment call for reshaping the instrument. And, in both cases, the "intentional arc" recalling Merleau-Ponty remains. The human actor, playing the instrument—whether musical or scientific—produces the skilled performance only through disciplined and learned practice, which when combined with knowing how and what one wants to produced, can also be enacted through the instrument itself, tuning and re-tuning its capacities in new or nuancedly similar directions. All this belongs equally to the traditions of instrument making in science and music.

Yet, there are also differences. The saxophone, born a hybrid, had as one of its core, technical features, the capacity for expressivity. The reed mouth-piece, through producing overtones, could extend the range of the instrument; its enlargement in the twentieth century produced the distinctive “saxophone” sound; and in the hands of a John Coltrane or a Zoot Sims could seem to “wail,” “cry,” or even “laugh” musically. This expressive musical instrument enables the individual performer to express, interpret differently through a wide range of auditory possibilities. Rather than “standardizing” an output, musical instruments may be said to “destandardize.”

The same is not the design intention for science instrumentation. As early as Galileo, the claim that hypothetically “anyone” could see what Galileo—but not what Aristotle or the Church Fathers—saw, because the scientific instrument “intends,” if not objectivity, at least wide intersubjectivity. Thus, the telescope even from Galileo on, gradually was developed so that the bodily capacities—other than critical, interpretive vision—were to be dampened down or removed. To place a telescope on a tripod removes the bodily magnified motions a hand held telescope was prone to; to eventually motorize the telescope to counteract the effects of earth motion further move it toward “objectivity” without removing the visual need for observation. This is to say that not only are the products of scientific action and musical action distinct, but that the way these actions are embodied points to that distinctively different trajectory.

ELECTRONIC JAZZ

All of the examples I have used above might be said to belong to an earlier modernity than the present of the twenty-first century. Essentially for the last few decades, a new set of increasingly dominant technologies have appeared and are being adapted into both new and old human practices, I refer, of course, to the emergence of electronic and computer simulative technologies. In science, which we have already seen is usually quick to adapt new technologies, electronic and especially computer simulative technologies are not even optional. No science that needs to calculate megadata infusions can do so without the electronic-computer processes. And, in part because these technologies are no longer handcrafted and no longer individually manufactured, the drift toward “off the shelf” instrumentation is now common. Contemporary science practice is highly electronically embodied.

In yet another not fully parallel fashion, the same has begun to happen to music practices, including jazz. At first it may simply be amplification,

but amplification is never simply neutral or transparent; it changes sound quality. And here several directions might be taken—the one to try as hard as possible to make the amplification “transparent” so that the change is minimized, or to resist amplification entirely—but also one can enhance the sound changes, either gradually or radically. And with this we see the beginnings of new instrumentation: *electric* guitars, basses, fiddles, keyboards, and drums. This road, once taken, allows many genres to appear.

On one level, electrifying the instrument may or may not be any more severe in terms of new sound, timbre, or power than the saxophone was over its predecessors, but on another level, the relocation of parts of the sound control location also changes where, along the human-instrument symbiosis, even newer sounds can be produced. Dials, levers and footpedals now regulate amplification and tone. The “electric” sound that sounds alongside or even displaces the acoustic sound is a paradigm shift. But this is not yet “electronic” in the contemporary sense.

The electric revolution also included the reproduction of sound, perhaps ironically paralleling the same chronology as the saxophone—from the late nineteenth century to the present. Again, the double trajectory appears: can the reproduction be “transparent” and make the recording “sound like” the live performance? It never has, but it has clearly made music more available and often comes close. The other trajectory, purposefully “away” from “original” sound is also possible and here lies the beginning of electronic music. Georgi Legeti, a Hungarian composer, began to splice tape fragments to construct new music. The process was slow, tedious, and arbitrary, yet the music that emerged was “like” no previous music. Later, electronic means of producing sounds, the Moog Synthesizer, for example, and still later, the digital production of sounds took the new electronic production of music down quite different paths.

I shall not follow these far in this context, but two observations are relevant: first, in the most recent forms of electronic music, the composer-producer of the music may be a single individual tweaking his or her machines, the DJ-composer of techno music is an example, wherein even the drum is replaced by the drum machine. Second, electronic music can be (but need not be) music that “no human can play.” Our DJ-composer can make his or her drum machine, simply, play faster than any human can play; or playing back a score onto a keyboard from a computer score, is not limited to the ten fingers of a single player, or even the twenty of a duet of players, but can use the entire keyboard in any combination to play.

Does this happen with jazz? Yes, exactly that and more. Of especial interest to me is the emergence of what is called the European new jazz. It is, as all jazz has been, both musically and *culturally* hybrid. And although

there are American roots—early Miles Davis electric jazz and some versions of free jazz—the newest form is European. It is a blending of techno and other electronic musics for dance (reviving an origin connection) with desires to be more at home in the European context. “A feature of the European jazz is that the rhythms are a mixture of acoustic and sampled sounds. Electric basses are out, upright bases are in, and drum kits are pared down to snare, bass, high-hat and cymbals. Turntables and samples create haunting, often ambient backdrops” (*New York Times*, Sunday, June 3, 2001, p. 28). This points in the direction of embodying jazz in new instrumentation, but it also further pluralizes the pluricultural roots of jazz. “Nordic Tone” meets northern African, French meets South American, and so on. And, our saxophone reappears, with Courtney Pine combining “samples and computer-generated rhythm tracks, underpinning some torrid soloing on soprano and tenor saxophones” (*ibid.*, *New York Times*, June 3, p. 28).

All of these possibilities, and many stranger than my illustrations, has led to a small music industry that has and is stimulating the development of new “instruments” in a proliferation much closer to the same frenzy concerning instruments in science. The boundaries again are blurring.

With the jazz scene and the new instruments, what began with new music poured into old instruments, today may have as one subdirection, both old and new music poured into new instruments. And with it a fusion of pluricultural elements that make jazz reflect so much more of our post-modern existence.

This page intentionally left blank.

Chapter 22

Embodying Hearing Devices Digitalization

In order to continue to lecture, travel, and teach in my seventies, I now must wear a pair of hearing aids, acoustic technologies. Mine are small, in-channel, and state-of-the-art digital devices. These have three programs: one for everyday use; one tweaked to the “cocktail party” or restaurant setting in which near, ambient noise threatens to overwhelm hearing one’s conversational partner(s); and one for telephone use. And, they are *expensive!*

There may be some personal irony here, more than three decades after I was engaged in all sorts of auditory experiments that became the basis for *Listening and Voice* in its first publication. Then, I had acute hearing and definitely, I did not need an acoustic technology as prosthesis. But, from then to now is a long time, and I propose to follow a phenomenological itinerary along that way and analyze the process and experience of “embodying” such devices. I have described this process of embodiment in a series of previous works, beginning with *Technics and Praxis* (1979) and more definitively in *Technology and the Lifeworld* (1990): When we humans use technologies, both what the technology “is” or may be, and we, as users undergo an embodying process—we invent our technologies, but, in use, they “re-invent” us as well.

In both books mentioned, I used optical examples beginning with eyeglasses. Embodying eyeglasses, I contend, is much easier and somewhat different than embodying hearing devices. Again, I begin autobiographically—but any optician would recognize the implied patterns as

symptomatic rather than individual: By my late fifties, I began to notice that it had become difficult to read telephone directories and the *New York Times*. So, after the proper examinations—themselves entailing sophisticated optical devices—I was given a diagnosis and a prescription for reading glasses. These I still wear, but I do not now need eyeglasses for nonreading purposes. However, there was a temporary time when I did need such mediating devices due to two closely timed accidents: chasing a porcupine in the dark after I heard him gnawing on my Vermont cabin, I encountered a tree twig and scratched my cornea. Not long after, one of my then infant children, with a finger poke, scratched the other cornea. So, after medical treatment, and then an eye exam, I had to wear prescription glasses for about a year while my corneas gradually returned to their proper shapes. I had to learn to see through glasses, to embody them.

If I revert to a third-person, anonymous description, I might recognize that what glasses do is to “correct” vision, in this case, to compensate for deformed corneal shapes. But just putting on glasses does not simply “snap” vision of the world into its now simply corrected sighting. Instead, one has to “learn” and bodily accommodate to wearing glasses. Phenomenologically, seeing is a whole-body experience. There are discernible changes in depth and motile perceptions, one is aware of this in the simple act of walking. The same happens with every new prescription. It is my bodily orientation that is the noematic part of this experience. This is even more noticeable if one wears reading glasses without taking them off to go get a drink of water—these mediating technologies produce a repeatable distorting effect that is quite perceivable. But, in my experience, and in those who have related theirs to me as well, embodying new eyeglasses to the point where they are nearly functionally “invisible” is a very quick process—taking maybe a day or two at most.

This is what I have previously called an *embodiment relation* with, in this case, optical technologies. I relate to my environment, my “world,” by means of such technologies and if they are well functioning then experientially they are “taken into my very sense of bodily experience.” My awareness of wearing glasses is a fringe awareness that gets interrupted only when there is back glare, or when the glasses slip off my nose, or when the lenses get dirty and smudged, when, in other words, something diminishes the normative transparency of the optics. “Breakdown” is a well-know phenomenon, made popular in the famous example of Heidegger’s hammer—his claim was that only when something is missing or broke does the set in assignments and involvements become clear.¹

With hearing aids, however, the technology of interest is an acoustic or auditory technology, a hearing “aid” ideally should function parallel to the

visual eyeglasses example. Unfortunately, auditory transparency is much more difficult to attain, a fact well recognized by audiologists and others. A significant number of people attempt to use hearing aids, but the difficulty of embodiment is sometimes such that they give up.

I am not sure when I first became consciously aware of my slow loss of hearing. As with reading glasses, I became aware, with aging, that my hearing was not as keen as it once was. In academic life, verbal situations are of focal importance and at some point I began to be aware that the “cocktail party” hearing problem began to occur. That is, in a conference or reception setting, background conversations and other noise, seemed to intrude and overwhelm my ability to hear what nearer conversants were saying. Similarly, in large lecture classes, the questions from the back of the auditorium seemed too faint or indistinct. Beginning to recognize that I was experiencing hearing loss, and remembering all those sixteen-hour days of the loud noise of the two-cylinder John Deere tractor I used on my father’s farm, I wondered if I had acquired “boilermaker’s disease.” However, I had also already noticed that many of my age peers among the faculty already wore hearing aids and their possibly loudest boyhood experiences were with stickball games. And, I knew I was too early to have the problem of Rock Concert disease either. But the clincher came via a more technological means.

While at an American Philosophical Association meeting in Boston, my wife and son were off visiting the Boston Science Museum and later invited me to revisit the place. One of the exhibits had to do with the senses, including hearing, and one could put on earphones and turn a dial to find out how many cycles per second one could perceive. I put them on and discovered that the upper range of my hearing only went up to 10,600+/- per second! Cognizant from descriptions of “normal” hearing that humans can hear between 200–20,000 cycles per second, I was shocked. I didn’t say anything, but on reaching home, quickly went to my *Macropedia* to find out what the “objective” situation was: I was relieved, in one respect, to discover that my range was relatively “normal” for someone my age (early sixties then). What counts as normal, apparently, is also age-related. Recently I read a newspaper article in which a store owner, constantly having teenagers hang out in front of his store, wanted to prevent this pattern of behavior. Somehow he knew that the hearing capacities of those below twenty differed by a small frequency range from those in their thirties. He installed a noise device that broadcast this upper end of the frequencies heard only by those at the lower age level, but remained undetectable even to those in their thirties!²

At this point, I decided to experiment. I purchased a single hearing aid, advertised as digital but not requiring a special set of exams. It did

work for a short period of time—it amplified to the degree that I could better hear the questions in the back of the room and in low background noise situations. But its limitations were equally obvious.

Unfortunately, with more age, I experienced more hearing loss, now quite perceptible, particularly in the conversational contexts already mentioned, but also in a home setting. So, after a series of audiological tests that showed the degree of hearing loss I ended up with my pair of digital hearing aids. Undergoing such tests, again with complex technologies tuned to various auditory phenomena, I began to learn things I never knew before. Part of what I learned was that even hi-tech, digital aids cannot restore frequencies lost, although within those that remain, these devices can be selective regarding enhancement or reduction and other manipulations. Again, this reflects my earlier claims about technologies—each transformation of experience displays an amplification/reduction structure. Eyeglasses do this; and so do hearing devices. But, in the case of speech a more subtle phenomenon arises. Vowels are temporally “longer” than consonants (and thus are more easily amplified); but since speech depends on the patterned gestalt of both vowels and consonants, the loss of consonants complicates hearing and understanding speech patterns. Digital devices, within limits, can enhance consonants. And, I experienced this with my first set of prescribed hearing aids. These were state-of-the-art devices, and they did make it easily possible to continue seminars, to allow much better auditory recognition of what the participants were saying. But, as technologically sophisticated as these were, once one was in the “cocktail party” situation, near conversants continued to be overwhelmed by the amplification of ambient surrounding sound.

If I refer back to *Listening and Voice*, it will be recalled that sound is simultaneously experienced as both surrounding and directional. Hearing aids, however, cannot simply match this phenomenon. And that was particularly the case with my first set. I had been advised to get a pair, and not a single device, even though I had more loss of hearing in one ear than the other. The reason was that I needed to relearn to hear directionally and this was presumably better accomplished if one began from the start with a pair of devices. Recall a parallel from optical history: monacles were once used, but are rarely, if ever, seen today. Instead eyeglasses as a “pair” are worn, although one lens may have a different grinding prescription than the other.

At first, I have to admit, while I recognized the improvement my devices provided, particularly in the conversation settings of home and seminar, the overall experience of hearing was clearly not anything like optical transparency with eyeglasses. My audiologist confirmed that this was, in fact, the normal experience for first-time users and urged me not to constantly

remove the aids when I was not in the situations where they functioned best. He used the now-popular “the brain must relearn the process, so it needs the constant use to do this,” also translated into, it takes a long time to become accustomed to hearing aids. My acoustic technologies remained quasi-opaque, although the recognition of this opacity was phenomenologically complex. For example, if I listened to music, if I didn’t know the piece, I could not be aware of what I was *not* hearing (for example, the higher frequencies), but, if I listened to a piece that was familiar, I could quite distinctly become aware that I was missing what I remembered hearing in my listening past! Thus familiar pieces sound “odd,” compared to how they “used to” sound. Other noticeable differences apply to “tinny” sounds in some of the retained sounds, particularly when coming from a stereo in another room. The phenomenon of what is lost, compared to that simply unheard, was evidenced in a seminar that Judy Lochhead and I sometimes share on the phenomenology of music. One evening, we were listening to a CD of sounds recorded by the ethnologist, Stephen Feld. He had recorded the very subtle sounds of water dripping, running, and so on, in the New Guinean highlands and was making a case for the auditory-dominant language of this tribe.³ But when we played the CD, it was “silent” for me for the first minute or two—yet all the others were obviously hearing something, so, only indirectly did I become aware that I was missing something. (Chronologically, this event preceded my use of hearing aids.)

A counterphenomenon also occurs. In *Listening and Voice* I made reference to the fact that we always hear ourselves differently from the way others hear us. Physiologically, this is because we hear via bone conduction as well as through the sound waves carried environmentally. So, the “acoustic mirror” of the tape recorder is always a surprise at first. But, hearing aids *amplify* bone conduction sounds—thus my self-perceived voice is much *louder* to me with hearing aids than without. This complicates relearning of auditory projection when speaking, and even close-up conversations. My voice to myself seems “too loud” and so I try to compensate and end up having others tell me I am speaking too softly—or, sometimes, too loudly. This is the inverse of what is foreground and background in nonacoustic technology hearing.

All of this continued to be noticeable with my first set of devices; but as I approached the second anniversary of use, I lost the pair while flying from a conference in California back to New York (I take them out to listen to earphones if watching a movie or TV while in flight), and after not being able to find them or retrieve them via lost and found, I ended up getting a “new, improved” set. Indeed, in the two years of use, electronic and miniaturization technologies had already improved on the previous technologies.

The new set automatically “communicated” between the individual devices (if you change a setting on one, the other automatically picks up the change); there was a more refined set of programmable selectivities regarding frequency changes; and one or more programs could be made directional (two tiny microphones in each device enhance the sense of the directional, almost like having “four” ears!). All this for only \$3,000 more than the original pair!

In certain ways, there were clearly perceptible improvements. Speech was indeed more distinct than with the previous aids; but most of all, in the second “cocktail party” setting, the directionality allowed me to hear close conversants even though the background noise remained amplified more than it would have without the devices. At least the cut-off point was better, but the amplification of background noise and the amplification of one’s own voice still remains noticeable and frustrating. Technological “intentionality” is simply not the same as one’s ordinary bodily intentionality. At the least, one can conclude that acoustic hearing devices are very far indeed from any of the hyped, utopian “bionic” beings of entertainment and science fiction imaginations or of virtual reality dreams. And, hearing aid embodiment does not come with either the same ease or degree of transparency that eyeglasses or optical technologies seem to have. Acoustic technologies are both more complex than the relatively simpler optical ones, but are still at a relatively early stage of development. But, I would contend, this is not because vision is in any way a “superior” sense, or a simpler one.

Hearing, however, is highly multidimensional—it implicates balance and motility in ways that implicate whole body experience intimately. Indeed, I would contend that technologies that come even closer to being prostheses for such more complicated experience, are more likely to be clumsy and less easily amenable to embodiment transparency. Just by way of one example, perhaps the oldest prostheses were “artificial” limbs, and while these have made various high-tech improvements, they have never yet allowed users to regain the gaits of walking, the gracious movement of dance, or more extremely with hands, the facilities of instrument playing that preprosthetic actual limbs allow.⁴ Technological transparency, with respect to human embodiment, remains at best a quasi-transparency.

I shall not take up here alternative hearing devices, such as cochlear transplants, but I shall briefly look at some variations from other acoustic technologies. First, if one goes back in technological history, earlier “hearing aids” were often hearing horns or ear trumpets. One end small to fit into the ear, the other fluted out similar to the shape of a trumpet, such devices could mechanically channel sound and thus amplify it. In this case, the hearing horn, precisely because it enhances directionality and dampens

ambient sound, did have a certain workability. Similarly, the stethoscope, which today remains a sort of icon of the medical profession, worked in a similar fashion. Indeed, the nineteenth century experimented with a whole series of auscultation devices, of which the stethoscope became the most successful one.

Auscultation, or the amplification of sounds from bodily interiors, when listened to by skilled and trained physicians, could detect heart murmurs, lung congestion, and a whole series of ailments that could not be detected either by visual or even tactile examination. Today, such skills are in decline and are largely displaced by newer diagnostic practices that rely on tests, or frequently, visual imaging (CT, MRI, PET scans, for example). When thought of as a variant on a hearing aid, the stethoscope, better than the hearing horn, dampens ambient sounds and amplifies sounds from bodily interiors. The tubes that carry the sound waves to the physician exclude ambient sounds in the examination room, and carry the amplified sounds of heart or lung processes instead.⁵ Again, this is an example of a mediating technology displaying an amplification/reduction capacity. These acoustic technologies remain simply “mechanical.” Today, most acoustic technologies of familiarity have become electronic, both analogue and digital.

Only briefly, these more contemporary variants include acoustic amplification capacities that go far beyond the mechanical display of acoustic phenomena. Technologies that include microphone-amplifier-speaker systems can make present sounds that cannot be heard at all without such technologies. Two years ago, I saw an interesting performance art example: in the installation, one lies down on a couchlike bed and listens to the amplified sounds of earthworms eating their way through a compost pile that is located directly below the couch. This is a less romantic, but in some ways biological equivalent to the amplification and recording of whale songs that are now part of familiar science documentary or enhanced music experience. With this style of instrumentation, however, one still hears frequencies within the normal range of hearing, thus the distant analogue to hearing aids is maintained while shifted to what could be called micro-sound. That is, the amplification of micro-sound is analogous to the optical microscope in that it makes the previously unheard hearable. (The much more extreme acoustic technologies, which translate infrasounds, sounds below the frequency ranges of human hearing, and compressed temporality, were examined in chapter 22.)

But perhaps the most ubiquitous acoustic technology that relates to hearing devices, is, of course the cell, or mobile phone, particularly those models that are worn in the ear. Here the variation is not directed at micro- or infrasound, but on the mediation of distance, which in its phone modality, is that

of the voices of others. I have previously analyzed the unreal, near-distance that such communication devices display phenomenologically. Geographical or near/far distances are technologically transformed into the virtually same near-distance. Although I, myself, have resisted the habitual use of cell phones, even I have had the experience of calling my son to find out where he is, only to find out that he is home on the first floor while I am on the third floor in my study. His voice is as discernibly nongeographic and “near” as when the call is made from home to university. This now everyday experience of near-distance has become a familiar feature of the lifeworld.

The technological capacity to produce microsound and even to translate infrasound and to diminish geographic distance, may suggest that today’s digital hearing devices may also eventually be able to follow such trajectories of development. Yet this is not to say that more radically constructed sounds could escape the constraints of all human embodiment. Rather, as with all prosthetic technologies, there will always remain “trade-offs.” What are called trade-offs are precisely those interface clues to human-technology relations wherein we always remain short of “cyborgian” unity. I am sure that I am not unique or idiosyncratic if I admit that I would just as soon do without my hearing aids—just as those who wear glasses would like to do without those. But, the trade-off is precisely the strength of such prosthetic technologies and I am well aware that without my acoustic devices, I simply could not do what I now can continue to do.

POSTSCRIPT

Since writing this chapter, I have acquired yet another, newer set of hearing devices—this time an open plan version that uses a transparent tube to conduct the sound, through a more open ear canal design. And, as with so much digital technology, once again marked, but incremental, improvements may be noted. The “stuffy ear” feeling of in-canal devices is gone; incremental improvement in surpressing ambient background noise occurs; and with a small remote control device, the adjustments are easier to make. In spite of these quite noticeable improvements, I remain far short of falling into the slippery slope belief that there will soon be anything like a fully transparent bionic recovery of “normal” human hearing. But the trade-off is better.

Chapter 23

Embodiment, Technologies, and Musics

INTRODUCTION

The history of humans producing and experiencing music is probably at least as ancient as *Homo sapiens sapiens* and Neanderthals or older, and just as diverse as every culture known to anyone. In this chapter I want to take both a long and broad look at music production and experience, but also focus particularly on “musical technologies” or instrumentation. Recorded music is primarily a phenomenon of late modernity, but to locate its particularities I will first undertake some of the historical and experiential variations suggested. The perspective I take here is triply “phenomenological.” First, it is descriptive: I take it the phenomenon of music is a highly varied one—I shall use the term, “musics,” in the plural to emphasize this point. I shall also avoid any ideological preference that favors one style, culture, or type of music and retain a musically relativist stance (which can, however, emphasize virtuoso results over novice ones). Second, I shall use variations in the form of concrete illustrations to exhibit this musical richness that the phenomenon displays. And third, I shall take note of the different forms of embodiment which the different music productions take.

WHERE WE ARE

If we begin from the here and now, and primarily in the context of late modern, global culture, I suspect the single largest set of produced “musics” is that which is usually called recorded or reproduced music, that is, the many varieties of records, CDs, iPods, tapes, broadcast recordings (both aural and audiovisual), and the rest. The electronic and digital explosion of music dissemination is so pervasive that it is simply taken-for-granted and therefore it is easy to miss its implications for a deeper understanding of the human experience of music. The above should be obvious to anyone.

When we turn to the very special world of musicians and musicologists, we might find a different take on this dominant technological embodiment of music. Musicians, of course, do have a unique perspective on music insofar as they are the humans who *produce* the original musical performances that their audiences or listeners experience. Musicologists (and I include composers here) are more the theoreticians and critics of music production and, again, have a unique take on musical performance and production. Stop! This is already taking too much for granted since it already presupposes a contemporary set of socially embedded practices that must take place within a much larger and more complicated scene. So, I shall open this analysis anecdotally: I was once a Dean of Humanities and Fine Arts in my university. In this setting the Music Department was clearly the premier arts department and its dominant and large graduate program emphasized performance—but it also had a core of *avant-garde* composers and musicologists. In the context of a highly charged tenure case, I had to learn something about the “sociology” of this group to be informed about the case at hand. What I learned was that the perspective that the majority of our musicologist-composers took regarding music was focused on a very specialized experiential technique: to “experience” music and judge it; one *read and analyzed the score*, a form of “text” as it were. But, specialized training also allows such “readers” to imaginatively *hear* the music through this reading. I understood this phenomenologically—but it also seemed strange since this type of music was clearly *technologically disembodied* and not fully a perceptual listening. Then, I learned something more—associated with this specialized visual score—imagined music experience, there was also a more selective musical ideology. Now while I would argue, phenomenologically, that any kind of music should be able to be so specially experienced by the trained score reader-imaginer, in this case the preferred style of music was that of a kind of pure atonality, a highly abstract, and “mathematized” music. This should not actually come as a surprise since the phenomenological practice of this kind of “reading-imagining” pretty neatly fits into

something similar to a mathematical experiential practice. Unfortunately and precisely because such expert experience takes this shape, it also leaves out of account many, many other varieties of possible experience and styles of music.

Second anecdote: A decade later, after completing my learning experience in deaning, I became interested in so-called synthesized music. My son, Mark, at that time was taking precollege composition classes using digital computational devices, and simultaneously I was communicating with and learning from Trevor Pinch about the history and sociology of analogue synthesizers. The three of us did a panel on synthesized music in Vienna (2001), and I returned the following year and gave a paper to an interdisciplinary group using some examples from electronically produced music. During the discussion, a couple of musicians, performers, chided me for allowing such a drift away from “pure music.” In this case, unlike the previous example, “pure music” turned out to be music performed and played only with the instruments appropriate to the periods in which the music was composed, that is, early music called for early instruments. In this case the narrowing of the “pure” was a performer’s sense of “authenticity” determined by a peculiar historical sense. Apart from possible historical problems to be found here—How can one know the precise instrumentation and arrangements from four centuries ago?—my interest was again more phenomenological. What is the range of musical possibility and its variations?

WHERE DOES MUSIC COME FROM?

To open up the questions I have raised, I will first turn to some anthropological-archeological speculation concerning human music origins. To this I will add observations related to the history of technologies. To find actual origins is probably a hopeless task—yet perhaps the simplest and most “bodily” origin of human produced music must include *singing*. I, myself, suspect that singing and some of its variants may precede or accompany the rise of language itself. Language itself is, after all, musical in some sense too. There is cadence, tone, pitch, and the like, although usually highly conventionalized. Singing can be at the least a sort of exaggeration of the sound patterns that are more limited in ordinary language. Nor would I want to exclude other bodily expressed musical or proto-musical sounds: whistling, yodeling, throat singing, individual and social musical expressions, clearly must go back as far as early humanity. But—so far—we have no way of recovering such sounds.¹

What about *instrumentally* produced music? Again, the task of finding the first uses of extra-body instruments is equally hopeless. Using a stick or other object to “drum” could be as old as humans, maybe even some animals. Woodpeckers with hard beaks are springtime drummers. In 1997 a cave bear bone flute, carbon dated back to 43,000+ BP (Before Present) was found and thought to be associated with Neanderthal sites and when analyzed with respect to its tuning style (distances between the holes yield an acoustical result that produces a diatonic tone scale not too dissimilar to that of much later Greek tuning systems—eighteen millennia later!).² And how far back do stringed instruments go? These would not be easily preserved since sinew and wood are unlikely to survive the millennia of their origins. My own suspicion is that since the technology of archery—string under tension in a bow arrangement—can have a musical variation by plucking or rubbing, and since any archer can hear the bow string make its “musical” sound when fired, some form of stringed instrument could be at least as old as archery which can be dated back at least to 20,000+ BP. Finally, in my anthropological-archeological-historical speculation I will surmise that just as archery was invented by almost all prehistorical cultures, so, likely were simple stringed musical instruments—I will add that I suspect the antique musical instrument kit included wind (Kudu horns in Africa; rams horns or shofars in the Middle East), percussion (drums are everywhere) and the previously mentioned string variants (in addition to the bodily expressive musics noted previously).

A PHENOMENOLOGY OF INSTRUMENTATION

In the previous illustrations and speculations, I have differentiated between two types of human musical production. In one set of examples, under “singing” and its variants, one may note that this type of musical production is directly *bodily expressive*. I have not even come close to exhausting such direct bodily musical expressivity. Singing, whistling, varieties of bodily sound production should also be expanded to variations on whole body movement such as dance, even self-percussion such as slapping oneself or other objects.

In the second set of examples, I began to suggest varieties of musical *technologies*, or instruments, at first directly incorporated into bodily practices. Flutes, simple stringed instruments, percussion instruments such as those suggested, arise many millennia ago and all fall under a distinctive human-technology use I have earlier called *embodiment relations*.³

By this I mean that the human or humans producing the music, do so *through* material artifacts or instruments. The simple examples cited are all “played” by bodily using these artifacts to produce musical sounds. Going into this practice, of course, there can be a learning, the development of special techniques, higher and higher skills of sound and music making, the development of styles, schools of musical traditions and instrumental developments. All this is presupposed by our instant ability to differentiate between the novice and the virtuoso performers in musical performances. Early instruments tended to be fairly simple even if widely varied, and I want to say, such simpler instruments also tended to demand highly skilled bodily movement.

The bone flute mentioned clearly called for fine fingering and exquisite breath techniques for any musical nuance; early stringed instruments usually utilized a small number of strings, but over time often became more and more complex with larger numbers of strings. These were plucked—with or without plucks, often with specially trimmed nail shapes—bowed, and later mechanically played. I have often been fascinated with instrument museums, particularly in Europe, which display the history of experimentation on stringed instruments. In this Eurocentric case it is interesting to note in passing that from a small number of strings ($1 < 6$) in early instruments, there was a period when the numbers increased ($6 < 12+$) but then returned to the now “classical” ($4 < 6$) set on violins through guitar string numbers for concert uses, that is with instruments that call for primarily hand play (the exceptions are harps and zitherlike instruments with many more strings; see below).

These are “technological” innovations, but remain within the range of clear bodily hand and finger capacities. By “classical” times, however, harps, zithers, and multistring instruments also appeared that were still finger or finger plus pluck played. In all these cases musical nuance was again attained through skilled hand/finger motion. A second step occurs once the playing was “mechanized” by using keys with mechanical plucks (claviers, harpsichords) or valves (brass and woodwinds). Here something quite interesting happened in music history. Arguments broke out concerning the alienation of “pure” hand playing as it “degraded” into “mechanical” playing. This happened in the transition from the harp to the keyboard instruments, and again from the simplest plucking devices to the more complex ones of the pianoforte.⁴ And it happened with winds and the introduction of valves over fingers in both woodwind and brass instruments. Objections regarding the loss of expressivity, the loss of nuance, the “mechanization” of music, and the loss of “romanticism” occurred.⁵ This was a “Heidegger”-like, response to modern technology now concerning musical technologies.⁶

One set of resistances is understandable: musicians had to learn new skills; such skills take time and discipline; and one does not immediately produce virtuoso performances—yet, once attained, who can doubt the expressivity of any master piano player over a novice, or take appreciative note of the new capacities of the human-instrument result. One can imagine, too, that with each style of production, it is possible for one to reify some kind of “purity.” Did our ancestors who sang claim that only singing was “pure” music? There have been moments in our histories in which only singing, and within song, only sacred tones are worthy, and there were times when polyphony was eschewed. And there have been religions that allow only a cappella hymns with no organs or other instruments allowed (except a tuning device!).⁷ But then, once a new human-instrument relation is attained, there can again emerge a sort of tradition-of-the-instrument that stabilizes and allows the sorting out of the virtuosi on the concert circuit. In short, I am suggesting that modern musical experience is contexted in a history-of-technologies setting in which instrumental innovation plays a major role.⁸

INSTRUMENTAL TRAJECTORIES

I am now ready, finally, to turn to *late* modern music and its embeddedness in late modern musical technologies, which introduce new complexities and possibilities for musics. For a brief moment I shall leap over the earliest, still mechanical technologies that allowed *recording*, and continue the ever more complex trajectory of human-instrument music transformations by taking initial note of *electric and electronic* technologies.⁴ These technologies might be added onto extant acoustic instruments, or they might also become part of the sound production itself. To make things simple, I shall focus on *amplification*. Today, even acoustically good auditoria often also use amplification—as in most opera houses. Here the attempt is to make the amplification as unobtrusive and “transparent” as possible, to have technologies that make it seem as if the singer were *not* technologically assisted. At the other extreme, amplification can take on its own unique preferred sound quality and becomes identified with the style of music itself—rock music is an example. In the first case, the musical tradition wants the *prima donna* to sing as if not amplified; in the second case the mike-amplified voice *is* the preferred voice of the rock singer. We do not want to hear the nonamplified voice of the rock singer.⁹ Amplification “magnifies” sound, but unavoidably it also transforms it. All technologies are nonneutrally transformational, including musical ones.

But this has always been so: If I take the Xhosa Uhadi as an example, this African single-string instrument is constructed very much like an archery bow, with a curved wooden tensioner, to which is attached a open ended gourd resonator, and which is played with a second bow. Its music utilizes basically two tones, but the virtuoso player can produce overtones within a minimalist style of playing that is then highly expressive and appreciated by the trained listener. The resonator both “magnifies” the sounds, but also transforms them. And, there is an obvious art to producing excellence even with simple resonating acoustical amplification—thus the sought after Guarneri and Stradivari violin phenomenon. I am claiming that electronic amplification lies on the same trajectory as resonance amplification, but its electronic possibilities are much more “active” than those of classical echo or resonance amplification. Electronic amplification carries the possibility of moving to a much more active sound transformation and even to sound production itself, as in electronic synthesizers, a possibility to be explored below.

I am, of course suggesting that not only do instruments—musical technologies—play an essential role in music production, but the history of instruments parallels that of technological history itself. The move is from simpler to more complex and compound technologies, and although this has been a background feature of this analysis, also this history evidences a move from direct bodily expressive musics to more instrumentally mediated musics, and in late modernity, on to musics that are or can be more *indirectly* related to first-person practices.

RECORDED MUSIC

I have set the staging now, to see that recorded musics are but another variation on musical production. And, recorded musics are themselves transitional, as I shall show. One development of recorded music lies in *repeatability* and *dissemination*. The “same” musical piece can be repeatedly played both temporally and spatially. The ancient antecedent of such a musical possibility is, of course, the *score*, which in certain ways also allows for repeatability and dissemination. Scores are text-analogues and relate to music performance in ways similar to written texts to verbal performances. And, as with so much late, or even *postmodern* scholarship, it was only by mid-twentieth century that the parochialism of Eurocentrism concerning scores was broken. While it remains relatively valid that the sources of European scoring systems may be traced to scoring conventions associated with sacred music, most particularly Gregorian chants, it now turns out

that quite specific scoring practices occurred at least as early as 3200 BP with a cuneiform version of scoring by the Sumerians.¹⁰

First, our “regional” scoring: Gregorian chants. This sacred singing, vocal and unaccompanied, became popular in the Roman Catholic Church from roughly 750 AD on. But its dissemination throughout the Roman West was assisted by an evolution of written scores. Notations associating the chant words with *neumes* (abstract figures) probably derived from Byzantine sources, but by the thirteenth century fully formed scores with a four-line staff with diamond shaped notes had already become common. (The five-line staff with round notes for modern Western music clearly follows this development.)¹¹ Scores, text-analogues for musical performance are, in effect, stable instruction sets for repeating a musical event. They make possible the repetition and dissemination of the “same” song, chant, or hymn over historical time and geographical space (for those who are “literate”). But scores may be thought of as perceptually, bodily “abstract.” To be “heard” through reading, a special skill like that noted above for musicologists and composers is required. And this is where the much later technology of recording changes everything! Recording “materializes” a performance, which can then be repeatedly played and perceptually heard. But, recording is also a *technological mediation* and thus displays features exhibited in any technologically transforming phenomenon.

A quick blink-of-the-eye history of recording technology begins with Thomas Edison’s mechanical version of the *phonogram*, later *phonograph*. A speaker tube + diaphragm + inscribing needle picked up air vibrations from sounds (voices at first); the needle inscribed “squiggles” onto a tinfoil wrapped roll cylinder; then when replayed the sounds were amplified through a simple resonating “horn” and one could hear the *recorded* sounds. Listeners were amazed, but fidelity was low—and the early “records” could hold only $2.5 < 4$ minutes of reproduced sounds. One effect which, in fact, lasted beyond the technologies that initially set the time limit, was that songs to be recorded were tailored to be $2.5 < 4$ minutes long. Caruso was one of the early singers recorded, but arias were often too long and thus more popular songs began to prevail. The popular response to the phonograph was strong, and while its intended uses included dictation, recorded speeches, verbally presented texts, the popular demands centered on music. And while early listeners often proclaimed the first phonographs to be very “lifelike,” it was obvious to the inventors that a development trajectory toward greater and greater acoustic *transparency* was needed.¹²

With a second blink, we leap to the mid-twentieth century hard discs, then vinyl records in several variations (78s, 45s, 33.3s). This transition included that of moving from mechanical to electronically amplified tech-

nologies and with it an easily perceptible improvement in fidelity and transparency. Early public relations performances of “high fidelity” included alternating musician and recorded musical pieces played behind closed curtains in a kind of auditory “Turing test” in which listeners presumably could not tell which was which.

The third blink brings us to the threshold of mostly present recording technologies, that is *digital* technologies, with digital tapes, CDs, and other variants. This development also is paralleled by the electronic change from amplifier tubes to transistors as well. If we accompany these three blinks with equally brief phenomenologies of listening, it is clear that the three styles of recording are markedly different variations of reproduction: The earliest records have a very poor “noise” to “message” ratio, if we use information theory terms. Both background sounds and sounds produced by the machinery itself threaten to overcome the sound of the voice or instrument being recorded. With mid-century high fidelity, this ratio is improved but not eliminated. The transparency trajectory, by then, includes all the tinkering, which includes sound studios, control panels (mixers, etc.), all designed to “purify” the recorded music to be as isomorphic as possible with the live performance.

The late-century move to digital technologies is also a move to much more “active” or *constructive* audio recording. For the first time, all background noise can be technically removed and the features of the recorded music can be highly manipulated. (One interesting effect of the move from “high fidelity” to digital systems noted by keen listeners, was the loss of a certain “richness” of timbre and overtones in the former, compared to crisp, but rather “thin” effects in early CD music. Thus, just as in the earlier noted “purity” preferences, there emerged aficionados of amplifier tube over transistor amplifier preferences.)

I trace this set of variations to make a point: each different technological system *transforms* the quality of sound or music heard in a different way. No system attains perfect transparency and each produces a different selectivity of sound qualities. There is no *neutrality* to recording technology. The acute listener is, of course, aware of this and thus one temptation regarding the evaluation of recorded music can occur: only a “live” performance is “pure” and is thus to be preferred. Now, however, a dilemma appears: how are we to account for the vast and deep social acceptance of recorded musics? Miniaturized players are everywhere, joggers, bench sitters, commuters; then, too, the home entertainment center with its larger audio components. Is this just a “trade-off”? No one can simply get up and go to a live performance at will, and the virtuoso performers of the concert halls or of rock bands are simply too expensive to go to hear every night, or

week, or month. Or, perhaps recording technologies add another layer, dimension, to the already established sound transformations that make up the musics we hear? I suggest that from the simplest vocally expressed singing—which itself is a vocal transformation of related speech—to instrumental produced musical sound, transforming beyond the limits of bodily voice, to additional amplifications and complexities of compound and complex audio equipment, on to even greater complexities of recording technologies, there is a continuum of transformations and variations, all of which are or produce distinctive *musics*.

This is not to say that a recorded piece of music is not distinguishable from, or distinct from a live performance. This would be equivalent to saying that a photograph is equivalent to that which is photographed. With this analogy, however, one should be able to see that there is also great photographic *art* in its own right. There is Ansel Adams with his nature photography; there is Robert Mapplethorpe with his bodies; there is Mann Ray with his eccentric subjects, and so forth; each has produced a visual display that can repeatedly be experienced and enjoyed. Other aspects of the photo/record analogy to the object/performance recorded also apply. For example, some subtle feature of the object/performance, since it may be returned to repeatedly, may show up more prominently when returned to again. It is in the variation and interaction through which “learning” can occur. The same photo/record analogy may as well be noted to apply to “great recording artists,” that is, to the sound “photos” that can repeatedly be heard in recorded music. Perhaps what is needed here, if it is not already extant, is a “discipline” concerning recorded music parallel to that which clearly already exists with photography? (Photography and film theory is well established within academia; whereas I doubt that there is an equivalent set of similar departments that deal with recording and recording theory?) The process of recording, re-recording, learning, and improving, is however, part of contemporary recording practice, much of it extra-academic. The end result emerges out of the technological interaction made possible by recording technologies.

DIGITAL POSTMODERNISM

In simplest terms, I now have three styles of human-technology music production: direct bodily production (singing-dancing variants), body-instrument variants, and then the “constructed” add-ons to simple instruments which include the recording technologies. I have suggested in all the “histories” with each new musical technology, there is a time of experi-

mentation and performance “tuning” that is entered. To listen to recorded music however, may entail a certain blindness to this process. The *production* of the recorded music lies behind and is presupposed by the end result. The studio is a complex location and process here involved. Acoustical space is constructed; takes, retakes, and increasing musical editing goes into the development of the record such that a simple live-performance recording becomes but one possibility out of many. Active “construction” is the norm. The editing process “picks and chooses” the best takes (the analogue with cinema is obvious) to produce the “best” result. Time forward and the age of the “remix.”

It is here that we also reach *postmodernity*. One of the themes concerning postmodernity, sometimes nostalgically decried, is the “death of the author” or the “subject.” And, there is the blurring of the boundaries between different “texts,” those of the author of the novel, for example, and the critic who increasingly claims equal rights as writer. My point takes its departure by my focus on the materiality of the technologies with which our writers, authors, subjects—now composers, performers, listeners interact. The musics that are studio and recording produced are no longer merely materialized performances; they are “constructed” pieces of repeatable musics. And a new set of possibilities begins to shape a new trajectory here as well.

I shall use the composer, Gyorgi Ligeti, made famous by Stanley Kubrick’s use of his music in the movies, *2001: A Space Odyssey*, and again in *Eyes Wide Shut* as my exemplar. Ligeti’s dissonant, atonal, and wild sounds were produced by means of what parallels a sort of Dada collage in visual arts. He cut and snipped sounds from recorded tapes, no longer simply musical instrument sounds, but all sorts of sounds, and then re-spliced these into his radically new styled music. This was a sort of bricolage product made possible by recording technologies, but made into creative and innovative music by this composer. This was a “synthesized” music. And it was a synthesized music before *synthesizers*.

Once again, I introduce a blink-set of historical moments: Mid-twentieth century saw the invention of electronic machines that could themselves produce the sound bits of the wild and radical sounds that Ligeti had produced by the slow process of cut and pasting tape bits. Trevor Pinch and Frank Trocco have noted this in *Analog Days: The Invention and Impact of the Moog Synthesizer* (Cambridge: Harvard University Press). While electronic music was experimental in several forms by the mid-twentieth century, and strange instruments such as the theremin, which was played by hand motion within an oscillator-generated electric field and which produced weird “whining” sounds quickly picked up by movie producers in Hollywood. The theremin turned out to be a very hard

to play instrument since the player simply had to make hand motions within the electric field and had no felt resistance such as frets or keys to feel. A single machine that could produce whole sets of electronically produced sounds was invented only in the 1960s by Robert Moog and, separately, by Don Buchla. Electronic oscillators, feedback circuits, filters, and dampeners were combined into boxes that could be played by a keyboard in the case of Moog, or by dials and switches in the case of Buchla. The new sounds, which could cover the full range of human hearing capacities, were early picked up by both moviemakers (particularly science fiction and horror styles), but also by rock and other already electronically amplified music makers (including Frank Zappa and the Beatles).

And while the specialized use of synthesizers remained somewhat restricted, a second blink is illustrated in the sort of popular hybrid synthesizer, the electronic keyboard, which soon swept the industrialized world in sales and popularity. Every high school “band” playing in a garage had one. By hybrid, I mean that keyboards often utilized *recorded* sounds, for example from extant instruments, and these could be played by anyone skilled in keyboard skills. (One could choose piano, harpsichord, koto . . . on to drums, organs and the like in a built-in bricolage of possibilities.) These hybrids are a form of “recorded” music, but “recorded” sounds that are then played, performed, in a new human-instrument practice. One might appreciate the disdain that skilled expressive piano players might feel since bodily skill could not produce nuanced sound differences on such machines. But that is not where the strength of this musical trajectory lies.

A third blink is even more contemporary and that is the invention and use of the *digital synthesizer*. As with the analogue synthesizers, the digital variety uses electronic means of producing sounds, but in this case parallel to digital photography, each sound is itself open to manipulation. In our own Stony Brook “composition lab” the machines have both a visual display and audio play. One can literally display the sound wave one wants to create and “sculpt” it according to wish. And, in this case there are no “originals” that have been recorded—this is no longer “recording” technology. And, it is a technology that can, through human-created “programming” produce music that exceeds ordinary human performance capacities. I close with a very simple example: one of my son’s composition hook-ups combined a digital keyboard with a composition program run on a desktop computer. One way of composing retained a traditional set of player-instrument relations. Mark could play his piece on the keyboard and the program would display it on the screen, and when ready after tinkering, he could save and print out a score. This was close to a traditional mode of

composing except that the slow and painful process of inking in notes by hand was replaced by an immediate full staff scoring of anything played. But—the process could also be reversed. Mark could produce a score with any number of notes on the staff, many more than the ten that one person could play, or even the twenty a duet of players could play, and moreover have them played at tempos too fast for any human to play! Is this, then, *posthuman* music?

PHENOMENOLOGICAL REPRISE

But for one more step, I have finished my anthropological-archeological-historical set of variations. And while I have usually referred to actual events, artifacts, and technologies, I have been using these as concrete *phenomenological variations*. All the musics referred to imply roles involving *embodiment, experienced perceptions*, in relation to musical sounds. By casting my variations in the context of a technology of instrumentation, I have been suggesting that contemporary musical technologies introduce new elements and possibilities into the production of musics. For example, once recording technologies were invented, different variations on human-technology relations were also introduced. With recording, the live performance while “causal” in the recording chain of events, once recorded recedes in experienced space-time. Then, with the capacity to manipulate the final result through studio-editing processes, a different set of roles for human actors enters the musical production. And, finally, with the variants on synthesizers, note that yet a different set of variations obtains. The composer becomes, as it were, the player as well. By “playing” the programs, the electronic machines, and then when satisfied, fixing or “recording” the result, one returns in a new way to the embodied player-instrument relation.

I have hinted at the possibilities for lovers of “purities” to react to these new musical variations at any point. Nostalgias for older modes and instruments, elitist reactions to new social contexts for musics, resistances to adapting to technologies can and do occur all along the variant spectrum. Neither should one forget that many musics and instruments are, in fact, abandoned. In contrast, the musical relativism I have practiced here emphasizes that creativity and innovation can in fact occur with and within each of the possibilities noted. I have also suggested that recorded musics are in some sense transitional, or at the least only one set of musical practices, and I will conclude with one final variation that is basically the most contemporary of all.

MUSICS FROM BEYOND HEARING

Ancient Chinese acoustics long ago recognized that there was sound beyond human hearing. Touching bells when sound had disappeared still yielded tactile perception of vibrations continuous with previously heard vibrations. But they had no way of recovering these within human perception. In a visual analogue, until the twentieth century all astronomy was optical, that is, light emitting, astronomy, but since first the invention of radio astronomy, since expanded from gamma waves to radio waves, astronomy can now *translate* the full frequencies of the microwave spectrum into visual images that are perceivable. While the sciences tend to favor visual imaging, the same translation variations are possible for sound.

Digital and computer processes today may translate data into images, or reverse the process and reduce images to data. This is the same process that lays behind my previous composition program referred to above. Once noted, one can search for and produce musics of many phenomena. But to attain perceptible results a mediated technological transformation is needed, a new “musical instrument” as it were. In the variations I am pointing to, both ultra- and infrasounds can be so translated. For example, biologists have recently discovered that just as whales produce changeable cycles of songs recorded only in the last few decades, that at ultrasound levels mice, too, sing courting songs to their ladies.¹³ Both these examples are “near hearing” examples. Much more extreme examples can come from phenomena previously not at all associated with musics. One imaginative artist has hooked up a geosatellite device that detects the wobble of the satellite to a digital piano and “played” the wobble music—it sounds quite like a Philip Glass or Steve Reich minimalist music.¹⁴ But here the embodied human is engaged only in the set up of the technology complex. A much more extreme example may be found in the work of Felix Hess, a Dutch physicist-turned-artist. He has recorded what he discovered to be the rhythms of high and low pressure storm systems off the Icelandic coasts, but that could be detected with infrasound equipment over Holland. By time compression (24 hours reduced to 8 minutes) with the consequent raising of frequencies into human hearing range, he has recorded what I call “earth songs.”¹⁵ The possibilities of musics not yet heard, within in some sense the possibilities of recorded musics, are far from exhausted.

Notes

1. IN PRAISE OF SOUND

1. Philip Wheelwright, *The Presocratics* (New York: Odyssey Press, 1966), p. 60.
2. See Patrick Heelan, "Horizon, Objectivity and Reality in the Physical Sciences," *International Philosophical Quarterly* 7 (1967): 375–412. Also, Don Ihde. "The Experience of Technology," *Cultural Hermeneutics* 2 (1974): 267–79.
3. Theodor Thass-Thienemann, *Symbolic Behavior* (New York: Washington Square Press, 1968), p. 147.
4. F. David Martin, *Art and the Religious Experience* (Lewisberg, Pa.: Bucknell University Press, 1972), p. 236.
5. Wheelwright, *The Presocratics*, p. 70.
6. Aristotle, *Metaphysics*, trans. John Warrington (London: J. M. Dent and Sons), p. 51 (*italics mine*).
7. Wheelwright, *The Presocratics*, p. 70.
8. *Ibid.*, p. 32.
9. *Ibid.*, p. 160.
10. *Ibid.*, p. 182.
11. *Ibid.*, p. 182.
12. Plato, *The Republic*, ed. Francis Cornford (London: Oxford University Press, 1945), p. 219.
13. *Ibid.*, p. 220.
14. Rene Descartes, *A Discourse on Method*, trans. John Veitch (London: Everyman's Library, 1969), p. 212 (*italics mine*).
15. *Ibid.*, p. 200.
16. *Ibid.*, p. 220 (*italics mine*).

17. Ibid., p. 225 (*italics mine*).
18. John Locke, *An Essay Concerning Human Understanding*, ed. A. S. Pringle-Pattison (Oxford: Clarendon Press, 1969), p. 9.
19. Ibid., p. 42.
20. Ibid., p. 15.
21. Ibid., p. 53.
22. Ibid., p. 53.
23. Ibid., p. 43.
24. Ibid., p. 66.
25. Ibid., p. 67.
26. Ibid., p. 67.
27. Plato, *The Republic*, p. 87.

2. UNDER THE SIGNS OF HUSSERL AND HEIDEGGER

1. See, for example, Edmund Husserl, *Cartesian Meditations*, trans. Dorion Cairns (The Hague: Martinus Nijhoff, 1960), p. 12; or his *Ideas: General Introduction to Pure Phenomenology*, trans. W. R. Boyce Gibson (New York: Collier Books, 1962), p. 49.
2. Husserl, *Ideas*, p. 39.
3. Martin Heidegger, *Being and Time*, trans. John Macquarrie and Edward Robinson (New York: Harper and Row, 1962), p. 51.

3. FIRST PHENOMENOLOGY

1. See Edmund Husserl, *The Crisis of European Science and Transcendental Phenomenology*, trans. David Carr (Evanston, Ill.: Northwestern University Press, 1970), pp. 191–257.
2. Maurice Merleau-Ponty, *Phenomenology of Perception*, trans. Colin Smith (London: Routledge and Kegan Paul, 1962), pp. viii–ix.
3. See Edmund Husserl, “Phenomenology,” ed. Richard M. Zaner and Don Ihde, *Phenomenology and Existentialism* (New York: Capricorn Books, 1973), for one discussion of the reductions. Unfortunately the use of the term *reduction* has both a bad and a good sense in phenomenological usage. When referring to reductionism as contrasted to the reduction of mediate assumptions the sense is negative.
4. Edmund Husserl, *Cartesian Meditations*, trans. Dorion Cairns (The Hague: Martinus Nijhoff, 1960), p. 7.
5. Ibid., p. 13.
6. P. F. Strawson, *Individuals* (London: Methuen, 1971). See chapter 2, pp. 59–86.

7. See Edmund Husserl, *Ideas*, trans. Boyce Gibson (New York: Collier Books, 1962), See chapter 9, pp. 235–59.

8. There is both a horizon to a particular thing with the implicit sense of absence and an absolute horizon to a field. Neither meaning of horizon should be confused with the ordinary signification of the distant line of earth and sky.

9. Merleau-Ponty, *Phenomenology of Perception*, p. xi.

10. *Ibid.*, p. 203.

11. Pamela Kay Haughawout, “I See’ Said the Blind Man” (unpublished paper, 1969), p. 4.

12. This point is easily established physiologically. It has been repeatedly pointed out by Georg von Bekesy in *Experiments in Hearing*, trans. E. G. Weaver (New York: McGraw-Hill, 1960), pp. 148 and 163–64.

4. THE AUDITORY DIMENSION

1. A phenomenological warning must be issued here. There is a strict difference between empty supposing and what is intuitionally fulfilled. Thus the exercise at this point is not strictly phenomenological but proceeds toward strict phenomenology by approximations.

2. Philip Wheelwright, *The Presocratics* (New York: Odyssey Press, 1966), p. 79.

3. Georg von Bekesy, *Sensory Inhibition* (Princeton: Princeton University Press, 1967), p. 9.

5. THE SHAPES OF SOUND

1. Søren Kierkegaard, *Either/Or*, trans. David F. Swenson, vols. I and II (Garden City: Doubleday, 1959), vol. I, p. 55,

2. *Ibid.*, p. 66.

3. *Ibid.*, p. 67

4. Edmund Husserl, *The Phenomenology of Internal Time Consciousness*, trans. James Churchill (Bloomington, Ind.: Indiana University Press, 1964), p. 149 (italics mine).

5. Erwin W. Straus, *Phenomenological Psychology*, trans. Erling Eng (London: Tavistock Publications, 1966), p. 4.

6. P. F. Strawson, *Individuals* (London: Methuen, 1971), p. 65 (italics mine).

7. Straus, *Phenomenological Psychology*, p. 7.

8. Maurice Merleau-Ponty. *The Visible and the Invisible*, trans. Alphonso Lingis (Evanston, Ill.: Northwestern University Press, 1968), p. 212.

9. J. M. Heaton, *The Eye: Phenomenology and Psychology of Function and Disorder* (London: Tavistock Publications, 1968), p. 42.

10. *Ibid.*, p. 42.

11. Ibid., p. 43.
12. Pamela K. Haughawout, "I See' Said the Blind Man" (unpublished paper, 1969), 4.
13. Echo-location by clicks is more accurate than by tones. "if continuous tones were used instead of clicks there was a significant loss of accuracy in the perception of the direction of the sounds, though the experiences had the same character of wave lengths greater than 2K." Georg von Bekesy. *Experiments in Hearing*, trans. E. G. Weaver (New York: McGraw-Hill, 1960), p. 287.
14. Philip Wheelwright, *The Presocratics* (New York: Odyssey Press, 1966), p. 79.

6. THE AUDITORY FIELD

1. Søren Kierkegaard, *Either/Or*, trans. David F. Swenson, vols. I and II (Garden City: Doubleday, 1959), 1:55.
2. Georg von Bekesy, *Experiments in Hearing*, trans. E. G. Weaver (New York: McGraw-Hill, 1960), pp. 172–73.
3. Philip Wheelwright, *The Presocratics* (New York: Odyssey Press, 1966), p. 98.
4. Erwin W. Straus, *Phenomenological Psychology*, trans. Erling Eng (London: Tavistock Publications, 1966), p. 287.
5. Von Bekesy, *Experiments in Hearing*, p. 164. "It was found impossible to construct an earplug whose attenuation for air borne sound was more than 35–40 db in the frequency range between 100–8,000 cps. Some authors . . . have attributed this limitation of performance to the vibrations set up directly in the bones of the head by the sound field."

7. TIMEFUL SOUND

1. J. M. Heaton, *The Eye: Phenomenology and Psychology of Function and Disorder* (London: Tavistock Publications, 1968), pp. 41–42.
2. Georg von Bekesy, *Experiments in Hearing*, trans. E. G. Weaver (New York: McGraw-Hill, 1960), p. 218: "In speech there is a definite tendency to break discourse up into certain chunks and try to recognize the chunks as units, disregarding the fine structure within the chunks."
3. Edmund Husserl, *The Phenomenology of Internal Time Consciousness*, trans. James Churchill (Bloomington, Ind.: Indiana University Press, 1964), pp. 76–79.
4. Ibid., p. 48.
5. Ibid., p. 121.

8. AUDITORY HORIZONS

1. I shall utilize William Richardson's unpublished translation of *Ereignis* as "event" rather than the published version of Joan Stambaugh who renders it "appropriation." Martin Heidegger, *Time and Being*, trans. Joan Stambaugh (New York: Harper and Row, 1974).

2. My exposition continues to rely on the unpublished Richardson translation.
3. Martin Heidegger, *Discourse on Thinking*, trans. John M. Anderson and E. Hans Freund (New York: Harper and Row, 1966), p. 83.
4. *Ibid.*, pp. 72–73.
5. *Ibid.*, p. 67.
6. Thomas Stoppard, “The Bridge.”

9. THE POLYPHONY OF EXPERIENCE

1. Martin Heidegger, *Poetry, Language, Thought*, trans. Albert Hofstadter (New York: Harper and Row, 1971), p. 26.
2. Edmund Husserl, *Ideas: General Introduction to Pure Phenomenology*, trans. W. R. Boyce Gibson (New York: Collier Books, 1962), p. 182.
3. Maurice Merleau-Ponty, *Phenomenology of Perception*, trans. Colin Smith (London: Routledge and Kegan Paul, 1962), p. 183.
4. One graduate student was first only gradually aware that she lacked visual imagination. Later, due to exercises in the use of visual imagery in variations, the student began to doubt whether she could do phenomenology. This may show more about implicit visualism than about phenomenology as such. She later performed brilliantly on auditory variations.

10. AUDITORY IMAGINATION

1. S. S. Stevens and Fred Warshofsky, *Sound and Hearing* (Time-Life International), 1966, p. 144.

15. DRAMATURGICAL VOICE

1. T. S. Eliot, “Murder in the Cathedral” (London: Faber and Faber, 1971), p. 18.
2. Isa. 6:1–10.
3. William Blake, “The Tyger.”
4. Robert Frost, “The Sound of the Trees.”
5. Unknown.

16. THE FACE, VOICE, AND SILENCE

1. Jean Paul Sartre, *Being and Nothingness*, trans. Hazel Barnes (New York: Philosophical Library, 1956), pp. 252–73.
2. For a visual counterpart, see Samuel Todas, “Shadows in Knowledge,” in *Dialogues in Phenomenology* (The Hague: Martinus Nijhoff, 1975), pp. 86–116.

20. BACH TO ROCK: AMPLIFICATION

1. Maurice Merleau-Ponty, *The Visible and the Invisible*, trans. Alphonso Lingis (Evanston, ILL.: Northwestern University Press, 1968), p. 21.

2. The difference between the live and the recorded performance is also affirmed by the rock listener, as Robert Messing, a student at Stony Brook, pointed out in a protesting response to this essay:

In fact, a recorded re-presentation of a rock concert emerges as radically incongruous from the live event, and this incongruity does not exist for the classical connoisseur listening to a recording, in that the ambiance of a live rock concert is characterized by sound levels which, from a practical consideration, cannot even be approximated at home, and additionally in that the rock concert atmosphere is essentially typified by the presence of several thousand tripping, dancing, and occasionally screaming freaks who collectively attain levels of mental energy that would probably kill a typical classicist of moderate temperament.

What Messing is pointing out is that this difference between the live and the reproduced concert is immense in that the fullness of volume and presence of the live concert is absent from the record. But is the instrumental quality absent? Messing agrees that rock is the celebration of amplification—the live concert gives *more* of that! Mr. Messing, interpreting his understanding of youth culture, indicates that the difference between “head music” and “body music” might,

better be characterized as that between reason and passion; not that reason may not be passionate nor passion reasonable but rather that youth demands from its music, as it demands from life, a brutally seductive intensity and emotional excitement that will grab the listener up from boredom and shake him loose from his foundations in a struggle to live continually, as it were, on the verge of orgasm. Youth has no use for disciplined, artful magnificence to which one must reach out with patience. If youth doesn't listen to classical music it is because, by virtue of its beauty, it finds it boring.

22. EMBODYING HEARING DEVICES: DIGITALIZATION

1. My own discussion of Heidegger's philosophy of technology, including the hammer analysis, may be found in *Technics and Praxis* (Reidel, 1979), pp. 103–29, and again in briefer form in *Technology and the Lifeworld* (Indiana University Press, 1990), pp. 31–34.

2. The news item I refer to was from the *Independent*, read during a trip to the UK—I did not jot down the reference.

3. Steven Feld describes an acoustic-rich language among New Guinean highlanders in *Senses of Place* (School of American Research Press, 1996), pp. 91–135.

4. An especially sensitive and phenomenologically insightful account of a high-tech limb may be found in Vivian Sobchack, *Carnal Thoughts: Embodiment and Moving Image Culture* (University of California Press, 2004).

5. See Bettyann Holzmann Kevles, *Naked to the Bone* (Addison Wesley, 1997), also Finn Olesen on the stethoscope in *Postphenomenology: Critical Companion to Ihde* (SUNY Press, 2006), pp. 231–45.

23. EMBODIMENT, TECHNOLOGIES, AND MUSICS

1. Here have been some attempts to find proxy sounds, for example, in materials that harden rapidly, such as some paints that may “record” sound vibrations during the hardening process, but to date there is very limited success with such techniques.

2. One cave bear flute with four holes has been dated to 43000+ BP and associated with Neanderthal tools. See *Science*, 11 April, 1997.

3. My phenomenology of human-technology relations may be found in *Technics and Praxis* (Reidl, 1979) and in more detailed form in *Technology and the Lifeworld* (Indiana, 1990).

4. Trevor Pinch and Karin Bijsterveld, “Breaches and Boundaries in the Reception of New Technology in Music” (Cornell, working papers, 2000), pp. 3–5.

5. *Ibid.*, pp. 6–7.

6. Martin Heidegger disliked any writing technologies other than the pen—even the typewriter detracted from the preferred, primordial practice of penmanship. See Michael Heim, *Electronic Language: A Philosophical Study of Word Processing* (New Haven: Yale University Press, 1987), pp. 210 ff.

7. Strictly a cappella singing was the tradition among many of the Germanic religious groups familiar to me as a boy in Kansas; my own equally Anabaptist group did allow a piano.

8. It is interesting to note in passing that instrumental history in science differs with that of instrumental history in music. In science it is presumed that many and newer instruments are better; one does not go back to “historical” instruments to perform science. But in music, historical instruments continue to be played and have value, and may even be thought of as having higher value.

9. My “Bach to Rock,” in *Technics and Praxis* (Reidl, 1979) analyzes this difference in detail.

10. Joe Monzo in his *Encyclopedia of Tuning* (Tonalsoft, 2004) describes and analyzes the Sumerian tablet which, since the mid-1950s has been recognized as a score of a hymn to the Moon Goddess, Nikkal. The tablet is dated to 3400 BP. R. J. Dumbrell also has a full account in *The Musicology and Organology of the Ancient Middle East* (London: Green Press, 1998).

11. See the Wikipedia on “Gregorian Chants.” [En.wikipedia.org](http://en.wikipedia.org).

12. A full history and analysis of both recording and broadcast fidelity may be found in Lars Nyre, *Fidelity Matters: Sound Media and Realism in the Twentieth Century* (Bergen: University of Bergen Ph.D. Dissertation, 2003).

13. Male mice have long been known to emit ultrasonic sounds in the presence of females, but only recently were these sounds noted to be more complex than mere

“squeaks,” and instead function as a sort of courting song. See Timothy Holy and Zhongshen Guo reporting in *PloS Biology*, vol. 3, issue 12, 2005.

14. “Ground Station,” by Daniel Joliffe and Jocelyn Robert, a CD that recorded a digital piano playing satellite signals at the Surrey Art Gallery, 2003, for reference: art-gallery@city.surrey.bc.ca.

15. Felix Hess, *Light as Air* (Heidelberg: Kehrer Verlag, 2003).

Index

- absence, 38–39, 53, 62, 83, 104–110, 150, 160, 161, 222
- Adams, Ansel, 260
- amplification, xv, 5, 51, 59, 77, 136, 167–173, 176, 229–240, 246–249, 256–262
- Anaxagoras, 9
- Anaximenes, 3
- Aristotle, 7, 9, 239
- atomism, 12–13, 43, 49, 60–64, 233
- auditory turn, 42, 44, 107
- auscultation, 249
- Bach, Johann Sebastian, 228–233
- Baez, Joan, 229
- Basso, Keith H., xiv
- Baudelaire, Charles, 71
- Beatles, 4, 228, 262
- Beethoven, Ludwig van, 4, 60, 76, 119, 199
- Bekesy, Georg von, xii, 78, 187
- Blake, William, 175
- blindness, 43–44, 59, 62, 64–66, 68–69, 71, 78, 86, 99, 123, 129, 135, 186, 195, 201–202
- Borges, Luis, 120
- Buchla, Don, 262
- Bull, Michael, xiv
- Burton, Richard, 171, 197, 199
- Cage, John, 189
- Carr, David, xi, xx
- Cartesianism, xi, 13, 21, 23, 25, 35–37, 40, 61, 68, 103, 134, 150–151, 156, 165 (anti-Cartesianism), 36, 150, 156
- contingency, 31, 124, 128–129, 134–136, 150–151
- Coppola, Francis Ford, xvi
- copresence, (of imagination and perception), 117, 124–128, 133–134 (of surroundability and directionality), 77, 83 (of “inner” and “outer” experience), 142 (of “word” and “wider signification”), 149
- Cuvier, Georges, 59
- dance, xiv, 156, 201–202, 254
- deafness, 43–44, 64, 78, 119, 135–136, 202
- Democritus, 9–10
- Derrida, Jacques, 198
- Descartes, René, 10–13, 104
- Dylan, Bob, 171
- echo chamber, 81, 222
- echo-location, xv, 54, 59, 69–71, 79, 97–101, 194–195
- electronic music, 240–241, 261
- Eliot, T.S., 170
- Empedocles, 8
- empiricism, (classical empiricism), 11–13, 26, 28, 32, 43 (phenomenological empiricism), 25–27, 43, 148
- epoché, 18–22, 28–35, 42–43, 62–63, 104, 204, 218–219

- existential possibility, 31–34, 67, 80–82,
 95, 123, 128, 153
 (as distinguished from *logical* possibility),
 30–31
 eyeglasses, 17, 243–250
 “face,” 110–111, 148, 161–162, 177–181
 “face-to-face” experience, 78–80, 177
 Fallman, Daniel, xiv, xvi
 Feld, Stephen, xiv, xvi, 247
 field shape, 75–77, 83, 123–124
 field-horizon ratio, 106
 figure-ground reversal, 187–189, 200
 focus. *See* noematic focus
 focus-fringe ratio, 74–75, 106
 Friedson, Steven M., xiv
 fringe. *See* noematic fringe

 Galileo, 5, 104, 235–236, 239
 Galison, Peter, xv
 Glass, Phillip, xvi, 264
 Goodall, Jane, 42
 Gregorian chanting, 257–258

 hallucination, 126–127, 132
 Handel, 157
 Haughwout, Pamela Kay, 267–268n
 hearing aids, 243–250
 Heaton, J.M., 64, 267–268n
 Heidegger, Martin, xix, 6, 17–23, 42,
 103–111, 115, 153, 165, 204,
 217–223, 244, 255, 266n, 268–270n
 Heraclitus, 7, 51, 71, 165
 Hess, Felix, 264, 272n
 Hilmes, Michele, xiv
 horizon, 18, 23, 38–40, 42, 50–54, 70,
 74–76, 89, 95, 102–111, 115–117,
 121, 124, 129, 132, 160, 176–182,
 189, 201, 222, 265n, 267n
 (as limit), 38–40, 105–106, 108–111,
 149, 161
 (as Open), 38–41, 105, 108–111, 161
 (as unsaid), 161–165
 (of invisible. *See* “invisible”
 (of significance), 176–179
 (of silence. *See* “silence”)
 (temporal horizon), 91–92, 95–96,
 108
 Husserl, Edmund, xix, 17–36, 42, 58, 60,
 89, 91–96, 99, 103–104, 110, 117,
 132, 152, 204–205, 215, 217–219,
 221, 266–269n

 improvisation, xii, 202, 236
 inner speech, 118, 121, 126, 131, 134–135,
 137–144, 150, 158–160, 178–180,
 210–215
 intentionality, 18, 21, 31, 34–44, 73–79,
 89–91, 96, 100, 110–111, 133–134,
 137–138, 159, 238, 248
 interiors of objects, 68–71, 81–83, 98–101,
 191–192
 invisible, 3, 9–10, 14, 51–54, 70–71, 80,
 105, 107, 110, 174, 267n, 270n

 Jones, Caroline A., xv

 Keller, Helen, 135
 Kierkegaard, Søren, 57–58, 60, 78, 155,
 206, 267–268n
 Kubrick, Stanley, xvi, 261

 Langsdorf, Lenore, xiii
 language as signification, 148
 language as word, 147–154, 158, 165, 168,
 170–172, 177, 179–181
 Latour, Bruno, xv, 238
 Lazardzig, Jan, v
 Ligeti, Gyorgi, xvi, 261
 Lochhead, Judith, xiii, xvi, 247
 Locke, John, 11–13, 26, 266n
 Loviglio, Jason, xiv
 Luther, Martin, 231
 Lyotard, Jean François, 198

 Mapplethorpe, Robert, 260
 Marceau, Marcel, 148
 Marvin, Lee, 171

- McLuhan, Marshall, 6, 227
 McLuhanism, 232–233
 Merleau-Ponty, Maurice, xix, 15, 27, 30, 37,
 41–43, 63, 68, 118, 150, 154, 190, 194,
 207, 233, 238, 266–267n, 268n, 270n
 Messing, Robert, 270n
 “mineness” of experience, 37, 139
 monophony, 187
 Montagu, George, 59
 Moog, Robert, 262
 moog synthesizer, xiii, 240, 261
 Motion-stability ratio, 88–89
 Mozart, Wolfgang Amadeus, 54, 78, 133,
 157, 231, 233
 multistability, 187–189, 200–202
 mute objects, 50–54, 57, 66–68, 70, 82, 88,
 94, 109, 111, 190

 naming, 107, 111, 142, 157, 185–186,
 193–194
 natural attitude, 22–23, 218
 Nietzsche, Friedrich, 14, 202
 noema, 29, 35–38, 41, 77, 94–96, 101–102,
 115, 122, 128, 176, 206, 244
 (noematic focus), 37–40
 (noematic fringe), 37–40
 noesis (noetic act), 35, 38, 93, 96–101, 115,
 128, 138, 176
 Nyre, Lars, 271n

 omnidirectionality of sound, 65, 75–76, 79,
 83, 124
 Ong, Walter J., 6
 otherness, 118, 138–139, 147, 171–176

 Pavarotti, Luciano, 197
 penetrability of sound, 81–82
 persona (per-sona), 14, 153–154, 167, 171,
 174
 phenomenological reduction, 18–19, 28,
 39, 217–219
 phenomenological variation, xix, 30–40,
 83, 263–264, 269n
 phonograph, 258

 Pinch, Trevor, xiii, 253, 261, 271n
 Plato, 9–10, 14, 104, 265–266n
 poetic word, 164
 polymorphy, 10, 20, 34, 37, 86, 118–119,
 124–128, 135, 233
 polyphony, 117–119, 124, 127, 132–134,
 142–143, 149, 158–159, 164, 168,
 177–180, 187, 190–197, 256
 postmodernism, 241, 257, 260–261
 protention (temporal), 91, 108
 Pythagoreans, 5

 ratio of said to unsaid, 162–165, 178
 Ray, Mann, 260
 recorded sound, 42, 75, 121, 136, 186,
 199–201, 213, 223, 227–233, 240,
 247–264, 270–272n
 reduction,
 (of experience to vision), 6, 8–13
 (of vision), 8, 10–13
 (See also “phenomenological reduction”)
 Reich, Steve, xvi, 264
 retention (temporal), 89, 92, 95–96, 102,
 108
 Richardson, William, 268–269n
 Ricoeur, Paul, xi, xix, 148

 Sartre, Jean-Paul, xix, 171, 177, 269n
 saxophone, 237–241
 Schram, Helmar, xiv
 Schwarte, Ludger, xiv
 self as “quasi-other,” 120–121, 124, 141
 shape,
 (hearing shapes), 61–68, 101, 191
 (shape of auditory field), 53, 74–77, 80,
 83, 107, 124
 singing, xx, 78, 138, 140, 157, 170, 175,
 186–187, 194, 253–256, 258, 260,
 271n
 Slaughter, Tom, xii
 Spallanzani, Lazzaro, 59
 Stevens, S. S., 269n
 Stoppard, Tom, 176, 269n
 Straus, Erwin, 267–268n

- Strawson, P.F., 32, 58, 266–267n
 surface (hearing surfaces), 68–71, 97–101
- Thass-Thienemann, Theodor, 6, 265n
- Thing-in-itself, 73, 138
- Tilman, Frank, xi
- Todas, Samuel, 269n
- Toscanini, Arturo, 134
- Trocco, Frank, xiii, 261
- unsaid. *See* horizon as unsaid
- variation. *See* phenomenological variation
- Visualism, 6–10, 13–15, 21, 54, 59, 62, 96, 110, 190, 198, 269n
- Vivaldi, Antonio, 132, 229, 233
- voice,
 (“authentic” voice), 172, 178
 (“inner” voice), 136–141, 152, 179–180
 (voice of the actor), 169–173
 (voices of animals), 186
 (voiceless language), 152–154
 (voice of the liturgist), 173–175, 187
 (voices of mute objects), 51, 57, 67–71, 87–89, 190–191
 (voice of poet), 175–176
- Warshofsky, Fred, 269n
- Weibel, Peter, xv
- Wheelwright, Philip, 265n, 267–268n
- Wittgenstein, Ludwig, 26, 33, 157–158
- writing, xx, 150–154, 169, 173–174, 197–202, 227, 258, 271n
- Xenophanes, 8
- Zappa, Frank, 262

PHILOSOPHY

Listening and Voice

Phenomenologies of Sound

second edition

Don Ihde

Listening and Voice is an updated and expanded edition of Don Ihde's groundbreaking 1976 classic in the study of sound. Ranging from the experience of sound through language, music, religion, and silence, clear examples and illustrations take the reader into the important and often overlooked role of the auditory in human life. Ihde's newly added preface, introduction, and chapters extend these sound studies to the technologies of sound, including musical instrumentation, hearing aids, and the new group of scientific technologies which make infra- and ultra-sound available to human experience.

"The significance and importance of the topic, and centrality of the topic to a particular field of study, is directly related to Ihde's strong reputation. His work is central to any study of the interface between the human body and technology, and his reputation began with, and still includes, the first edition of this book. He has been important to the field for thirty years and continues to contribute new insights."

—Lenore Langsdorf, coeditor of *Recovering Pragmatism's Voice: The Classical Tradition, Rorty, and the Philosophy of Communication*

"This book is pathbreaking. It is still the only detailed phenomenology of listening and voice that we have. Philosophy, up until Ihde, was obsessed with visual representation and visual metaphors. Ihde contrasts visual perception with aural experiments, mixing up the examples and talking about pop music and opera in the same analytical voice."

—Trevor Pinch, coauthor of *Analog Days: The Invention and Impact of the Moog Synthesizer*

Don Ihde is Distinguished Professor of Philosophy at Stony Brook University, State University of New York. He is the author of many books, including *Experimental Phenomenology: An Introduction*, also published by SUNY Press, and *Bodies in Technology*.

State University of New York Press
www.sunypress.edu

ISBN: 978-0-7914-7255-2



9 780791 472552